



# **BSS Examination Checking Procedures**

**Core Checks for Privately Owned & Managed Boats  
and Parts 2-9 of Hire Boat Requirements Examinations**

**Non-controlled Open Version**

**Edition 5 Version 0.1 September 2023**

Copyright © 2023

**This version of the core Examination Checking Procedures (ECP) is a non-controlled document version**

**The document may be subject to possible change.**

**There have been changes from the previous version with the aim of improving clarity, delivery, and guidance for users.**

## Introduction

The checking procedures contained in this book detail the methods by which the Boat Safety Scheme (BSS) and its owners, the navigation authorities, require BSS Examinations to be performed on privately owned and privately managed vessels, and on hire boats.

Parts 2 to 9 of these Core BSS Checks apply to privately owned and privately managed vessels and to hire boats. Within Parts 3, 6 and 8 there are a total of 14 Check items that are Advice Checks for privately owned and managed vessels, but these Checks are mandatory Requirements in the Hire Boat Requirements.

Until further notice, other classes of commercial boat are likely to need to be examined against all relevant BSS Check Items listed in the BSS Examination Checking Procedures Edition 1, dated April 2002 to support their registration or licensing as stipulated to the boat's operators by the relevant navigation or harbour authority.

In respect of privately owned and managed boats and hire boats, BSS Examiners are required to follow these fifth edition BSS Examination Checking Procedures and so the consistent application of the Procedures by BSS Examiners will be assessed against this edition from its launch date.

It is critical that BSS Examiners are familiar with the contents of this document to help ensure that the application of the BSS Requirements is consistent and accurate.

Any questions or comments about this document or its contents, or any suggestions for revision or improvement, can be directed to the BSS Office.

Boat Safety Scheme  
c/o National Waterways Museum  
Ellesmere Port  
South Pier Road  
Ellesmere Port  
Cheshire  
CH65 4FW

Telephone 0333 202 1000

Website: [www.boatsafetyscheme.org](http://www.boatsafetyscheme.org)

Email: [bss.office@boatsafetyscheme.org](mailto:bss.office@boatsafetyscheme.org)

## Table of Revisions

Date	Rev. Ref	No. of Revisions	Page Description



## **General Guidance**

### **Before the Examination**

Don't forget that it is the owner's responsibility to always maintain the boat's compliance with the BSS Requirements when the boat is on the water as a condition of their navigation authority licence, mooring or registration. The only two roles that a BSS Examiner has are, to check compliance against the Requirements, and pass on BSS advice and guidance as appropriate.

Owners have a responsibility to prepare the boat for Examination, including: -

- full access to any system or feature that requires inspection: and,
- organising supporting documents where required as evidence of compliance; and,
- the supply of fuel and/or power as needed.

Try to remember to discuss this when you are making the Examination arrangements with your customer. There is more information on the BSS websites that should be helpful in this regard.

### **Carrying out the Examination**

The navigation authorities are relying on the fact that boats are checked against procedures and are certificated appropriately.

Examinations must be carried out methodically in accordance with the procedures, instructions and guidance as published in this document and on the BSS Examiner website. Examiners are required to use a checklist during all Examinations to ensure Check items (a.k.a. Checks) are not missed.

You will need to approach each Examination with resolve and determination. Some physical effort or even discomfort may be required to achieve some of the Checks, but not to such an extent that may result in damage to your health, the boat or boat system components.

You may need to search for items you are required to see, such as portable fire extinguishers or LPG line joints. You will also need to look for items that should not be stowed inappropriately such as spare LPG cylinders, or self-contained LPG appliances, or spare petrol containers. Make every effort to look in any lockers or cupboards where such items are likely to be stored, including cockpit and galley cupboards, engine spaces, etc.

Ultimately, it is your duty to apply these checking procedures diligently. Please remember that if you are unsure whether or not some aspect to a boat is compliant, you can contact the BSS Office for assistance. The BSS Office supports you without assuming your responsibility to carry out the Examination diligently.

### **Health and safety**

Examiners have responsibility for their own personal health and safety whilst carrying out Examinations.

If on arrival on site it is apparent the boat is in a dangerous condition, or if you identify a dangerous condition during the Examination, leave the boat safe but do not proceed with the Examination, ensure you record your decision as a 'terminated Examination' with the reasons for the termination, and inform the BSS Office.

Examiners must apply any general, or specific, safety principles and guidance from the Core LPG and Electrical Knowledge elements of the BSS Examiner training programmes.

Examiners are guided to follow the recommended BSS 230V AC Safe Disconnection Process as set out at Appendix F of this document prior to starting Examinations on boats with permanently installed 230V AC systems on board.

### **Recording and reporting the Examination**

You must make and retain records of every BSS Examination in the BSS Database, and in accordance with the instructions and guidance as published in the BSS Examiner Help Centre and webpages..

## How These Procedures Are Laid Out

The following Check Item structure and layout has been adopted throughout.

<b>Check Item number</b> e.g. 7.3.1 locker drain check A unique reference with part number (7), section number (3) and then item number of section (1).	<b>Check Text</b> A précis of the Requirement posed in the form of a question to which the answer must be 'yes' in order to pass.	<b>Check Status</b> <b>R</b> = Requirement <b>A</b> = Advice check (only relevant to privately owned and managed vessels)
<b>Checking action to be performed</b> When to apply the Check and when it is not applicable. What must be examined and how it must be checked. [For example, check the location or perhaps markings, or another example, look and feel to assess the condition of the item.]	<b>Requirements that must be met for a pass</b> What criteria must be applied to establish whether the Check Item is passed or failed. Under what circumstances a date specific Requirement is to be applied. Each Requirement is applied within the limitations of the Checking action carried out by the Examiner. [For example, the description of the required location or marking, or, a statement that the item must show no signs of fuel leaks or missing components. etc.]	
<b>Supplementary information</b> [As examples shown below, where relevant this component includes supplementary information needed by Examiners to be able to apply the Check Item] <b>Applicability</b> [Information relating to the applicability of the Check Item and any reporting implications and actions that the Examiner should take account of in the event of non-compliance] <b>Safety advice</b> [Specific safety advice for Examiners related to the Check Item] <b>Guidance for owners</b> [Guidance that may steer owners towards added safety, which is sometimes mandatory to provide to your customers] <b>Examiner action</b> [Guidance for Examiners, particularly regarding the extent and order of their Checking actions and their personal safety]		

## Glossary Of Terms

<b>accessible for inspection</b>	Made available for inspection and capable of being seen and reached.
<b>accommodation space</b>	Space surrounded by permanent boat structure in which there is provision for any of the following activities: sleeping, cooking, eating, washing/toilet, navigation, steering. Spaces intended exclusively for storage, open cockpits with or without canvas enclosures and engine rooms are not included.
<b>appliance</b>	A device or piece of equipment designed for a particular use, used for performing or for facilitating the performance of a particular function. (Examples include but are not limited to: heaters; boilers; cookers; refrigerators; lights; and, 'bullseye' decklights).
<b>appliance with continuously-burning flame</b>	Appliances designed to be left unattended with the main burners operating over long periods. Examples include LPG fridges, cooker ovens, central heating boilers and space heaters.
<b>battery space or box</b>	An enclosure specifically designed to contain the batteries only.
<b>damage or deterioration</b>	Damage or deterioration materially affecting, or likely to affect, the integrity, efficiency or operation of the item or device. [For example, a crack through the bowl of a clear bowl filter would constitute damage warranting a fail but damaged paint or a torn label on the filter would not].
<b>engine space</b>	Space or compartment of the boat containing main or auxiliary engine(s).
<b>ventilation</b>	<p><b>fixed ventilation</b> – Ventilation that cannot be closed without the use of tools.</p> <p><b>total effective area of fixed ventilation</b> – The total area of fixed ventilation provision, as measured.</p> <p><b>calculated fixed ventilation</b> – The ventilation Requirement as calculated using the formula at Appendix K.</p>
<b>interior of the vessel</b>	<p>Anywhere within the confines of the hull apart from:</p> <ul style="list-style-type: none"> <li>those areas where the arrangements of a self-draining cockpit helps prevent leaked fuel or escaping LPG vapour entering any space, including accommodation, engine and bilge spaces [see Check Item 7.1.1 for full criteria];</li> <li>open locations on deck or on a cabin roof where leaked fuel would flow directly overboard unimpeded and where any openings into any space or any source of ignition are not within 0.5m metre distance.</li> </ul>
<b>light manual force</b>	The application of a minimum manual force entirely proportionate to the potential for movement of the item being checked.
<b>lines, pipes and hoses</b>	<p><b>Line</b> is a generic term referring to the overall facility, i.e. fuel-filling line.</p> <p><b>Pipe</b> refers to rigid metallic lines, i.e. fuel filling pipe.</p> <p><b>Hose</b> refers to a line made of flexible material, i.e. fuel filling hose.</p>
<b>normal laden waterline</b>	The waterline observed at the time of an Examination (providing no attempt has been made to change the waterline by removing or adding to any part of the vessel's structure, fittings or equipment (including LPG cylinders), or by emptying or filling any tanks in whole or in part).

<b>open-flue appliances</b>	<p>Open-flue appliances take their air for combustion from the space in which they are installed.</p> <p>Open-flue appliances will always be fitted with a draught diverter, which provides a draught break between the primary flue on the appliance and the secondary flue connecting the draught diverter and the flue terminal.</p>
<b>open vessel</b>	A vessel in which all the accommodation is completely open to the elements.
<b>overnight accommodation</b>	A cabin with berthing arrangements (e.g. beds, bunks, dinettes) used for overnight stays.
<b>portable appliance</b>	An appliance which is not permanently connected to a fuel supply and/or where its location is not permanent.
<b>pre-made</b>	Where an item or connection, such as on a hose assembly or electrical cable, has been made with the intention that it will be permanent. It will not be possible to take apart any such items or connections without causing permanent damage
<b>readily accessible</b>	Capable of being reached for operation, inspection or maintenance without removal of any craft structure or use of any tools or removal of any item of portable equipment stowed in places intended for storage of portable equipment such as lockers, drawers or shelves.
<b>sanitation system</b>	A system comprising equipment designed for installation on board a vessel, to receive, retain, treat or discharge sewage, and equipment using any process to treat such sewage.
<b>sea-going boat</b>	A boat that is used on tidal waters.
<b>seen, reached</b>	<p><b>Seen</b> - Where an item can be assessed with the naked eye, or by the use of a mirror.</p> <p><b>Reached</b> - Where an item can be touched and assessed by hand.</p>
<b>suitable proprietary manufacture</b>	An item or device that is, on the face of it, manufactured for the purpose determined during the Examination. [For example, a solenoid-controlled valve in the LPG cylinder locker must be presumed suitable, but Examiners must not accept valves marked not suitable for use with LPG or DIY arrangements with 'home-fashioned'- style linkages or exposed motors].
<b>unintended movement</b>	Any movement beyond that likely to be intended by the manufacturer, and/or where movement is likely to affect the integrity, efficiency or operation of the item or device.

**BSS Examination Checking Procedures – Part 2**  
**Permanently installed fuel systems and fixed engines**

There are seven relevant BSS General Requirements:

1. All permanently installed fuel systems and fixed engines must be designed, installed and maintained in a way that minimises the risks of explosion, or of fire starting or spreading.
2. Fuel filling arrangements must prevent any overflow from entering the interior of the vessel.
3. All fuel filling points must clearly identify the fuel in use.
4. Marking must be provided to identify the location of fuel system emergency shut-off devices, or their means of operation, which are not in open view.
5. All permanently installed fuel systems must be designed, installed and maintained to ensure fuel-tight integrity.
6. All permanently installed fuel tanks and fuel system connections must be accessible for inspection.
7. The pressure systems of steam-powered installations must have a current inspection certificate issued by a recognised competent person.

**2.1 Fuel filling points**

<b>2.1.1</b>	<b>Does the location and condition of the fuel filling point ensure that any fuel overflow is prevented from entering the interior of the vessel?</b>	<b>R</b>
<p>Check the location of fuel filling points and assess the potential for any overflowing fuel to enter the interior of the vessel.</p> <p>Check the condition of fuel filling points where they can be seen or reached, and assess the potential for any overflowing fuel to enter the interior of the vessel around the filling point.</p>		
<p>Fuel overflowing from filling points must be prevented from entering any part of the interior of the vessel.</p> <p>Accordingly, fuel filling points must be positioned so that...</p> <ul style="list-style-type: none"> <li>• the camber or configuration of the deck; <b>or</b>,</li> <li>• a coaming; <b>or</b>,</li> <li>• a diverter arrangement;</li> </ul> <p>... prevents overflowing fuel from entering the interior of the vessel.</p> <p>Fuel filling points must be secure, and free of signs of damage or deterioration which could lead to overflowing fuel entering the interior of the vessel.</p>		
<p>Applicability – this Requirement does not apply to the following provided there is no risk of unseen spillage:</p> <ul style="list-style-type: none"> <li>• historic (i.e. bona fide ex-working) diesel-engined boats (Examiners should seek guidance from the BSS Office when determining whether a boat is a bona fide ex-working boat); <b>or</b>,</li> <li>• diesel tanks, of up to a maximum capacity of 30 litres.</li> </ul> <p>Applicability – open vessels such as RIBs having a continuous deck or sole that is fuel-tight to the interior of the vessel and bilge spaces, meet this Requirement.</p> <p>Guidance for owners – in order to address the potential for explosion and/or fire:</p> <ol style="list-style-type: none"> <li>i) petrol overflowing from filling points must be avoided through careful fuel handling; <b>and</b>,</li> <li>ii) beware of the accumulation of petrol vapour where petrol filling points are located in self draining cockpits.</li> </ol>		

<b>2.1.2</b>	<b>Is the fuel in use correctly and clearly marked on or adjacent to the fuel filling point?</b>	<b>R</b>
Check for markings on or adjacent to fuel filling points.	<p>The specific fuel type in use must be correctly and clearly marked on or adjacent to all fuel filling points:</p> <ul style="list-style-type: none"> <li>• ‘Diesel’, ‘Fuel Oil’, ‘Gas Oil’, ‘DERV’, or ‘Biodiesel’; <b>or</b>,</li> <li>• ‘Petrol’, or ‘Gasoline’; <b>or</b>,</li> <li>• ‘LPG Butane/Propane’ as appropriate; <b>or</b>,</li> <li>• ‘Paraffin’ or ‘Kerosene’; <b>or</b>,</li> <li>• ‘Petrol’.</li> </ul>	
<p>Examiner action – Examiners must refer to Section 1 of Appendix 2 for essential information on internationally accepted fuel symbols. The marking of a fuel filling point with an appropriate international symbol is acceptable.</p> <p>Applicability – the use of embossed tape (e.g. Dymo) is not acceptable. The marking must be legible with all lettering complete.</p> <p>Applicability – marking fuel filling points solely with ‘fuel’ or ‘gas’ is not acceptable.</p>		

<b>2.1.3</b>	<b>Are all disused fuel filling points disabled?</b>	<b>R</b>
<p>Check all fuel filling points and other deck connections. Identify any that are marked as fuel filling points, or that may be taken to be fuel filling points but are no longer connected to a fuel tank.</p> <p>Check for signs of disabling.</p>	<p>Fuel filling points that are no longer connected to a tank must be permanently disabled to such an extent that it would require the use of tools to remove the disabling method.</p>	
<p>Applicability – the use of a suitable proprietary adhesive to secure filling point caps or plugs in place etc meets this Requirement.</p>		

<b>2.1.4</b>	<b>Does the internal diameter of the fuel filling point meet the specified requirements?</b>	<b>R</b>
Measure the internal diameter of each fuel filling point.	<p>Fuel filling points must have a minimum internal diameter of:</p> <ul style="list-style-type: none"> <li>• 31.5mm (1¼in) where they are connected to a filling hose; <b>or</b>,</li> <li>• 28.5mm (1½in) where they are connected to a filling pipe; <b>or</b>,</li> <li>• 28.5mm (1½in) where they open directly into a tank.</li> </ul>	
<p>Safety advice – metallic measuring devices are not to be used on metallic petrol filling points.</p> <p>Applicability – if it is not practicable to measure the internal diameter at fuel filling points, an estimate based upon the external diameter of the fuel filling line can be made.</p>		

## 2.2 Fuel filling lines

<b>2.2.1</b>	<b>Are the fuel filling line connections free of signs of leaks and in good condition, and are all fuel filling hose connections accessible for inspection?</b>	<b>R</b>
<p>Check the accessibility of fuel filling hose connections, and check their condition by sight and touch.</p> <p>Check the condition of fuel filling pipe connections where they can be seen or reached.</p>	<p>All fuel filling hose connections must be:</p> <ul style="list-style-type: none"> <li>• accessible for inspection; <b>and</b>,</li> <li>• secure; <b>and</b>,</li> <li>• free of signs of leaks; <b>and</b>,</li> <li>• free of signs of damage or deterioration.</li> </ul> <p>Fuel filling pipe connections must be:</p> <ul style="list-style-type: none"> <li>• secure; <b>and</b>,</li> <li>• free of signs of leaks; <b>and</b>,</li> <li>• free of signs of damage or deterioration.</li> </ul>	
<p>Applicability – where hose connections are not accessible for inspection, Check 2.2.1 must be recorded as ‘not verified’ on your checklist, and it must be considered that the Check has not been completed until such time as the condition has been verified.</p>		

<b>2.2.2</b>	<b>Is the fuel filling line self-draining so that fuel is not retained and is it free of kinks or other restrictions?</b>	<b>R</b>
<p>Check the fall of each fuel filling line where it can be seen or reached.</p> <p>Check for any kinks or other obvious restrictions in fuel filling lines where they can be seen or reached.</p>	<p>Fuel filling lines must be connected to the top of the fuel tank and be ‘self-draining’ i.e. fall continuously from the filling point to the fuel tank connection so that fuel is not retained.</p> <p>Fuel filling lines must not be kinked or restricted.</p>	
<p>Applicability – fuel filling lines must not have their internal bore diameter restricted to less than 28.5mm (1<sup>1</sup>/<sub>8</sub>in) for pipe or 31.5mm (1<sup>1</sup>/<sub>4</sub>in) for hose.</p> <p>Applicability – petrol filling pipes connected to the sides of metal petrol tanks are acceptable provided that the tank spigot is welded to the tank and extends above the top of the tank.</p> <p>Applicability – diesel fuel filling lines into the sides of fuel tanks are acceptable provided the arrangements comply with the Requirements at 2.10 and 2.11.</p> <p>Applicability – diesel fuel filling lines into fuel tank balance lines are acceptable provided the arrangements comply with the Requirements at 2.9, 2.10 and 2.11.</p>		

<b>2.2.3</b>	<b>Is the material of the fuel filling line suitable and in good condition?</b>	<b>R</b>
<p>Check the material and condition of fuel filling lines which can be seen or reached.</p> <p>Check the markings on any fuel filling hose.</p>	<p>Fuel filling lines must not show signs of fuel leaks, damage or deterioration.</p> <p>Fuel filling hose must be marked as suitable for the fuel in use or supported by an appropriate declaration.</p>	
<p>Applicability – diesel filling hose in good condition may be accepted without marking or declaration, provided it can be examined over its entire length.</p> <p>Applicability – hoses marked ISO 7840, ISO 8469, ISO 15540, SAE J 1527, DIN 4798 or RINA DIP/66/96 may be accepted as being suitable for use with petrol or diesel.</p> <p>Applicability – in cases where the filling hose is suitably marked, enough of the hose must be accessed in order that the Examiner can make a reasonable assessment as to its general condition.</p>		



## 2.3 Fuel tank vents

<b>2.3.1</b>	<b>Does every fuel tank have a vent facility?</b>	<b>R</b>
Check all fuel tanks for the provision of a vent facility.	A vent line must be fitted to each fuel tank, or a vent must be fitted to either the filling cap, filling line, or tank top.	
<p>Applicability – multiple diesel fuel tank arrangements having a shared vent facility are acceptable provided the arrangements comply with all other Requirements at 2.3 and 2.4.</p> <p>Supporting information on fuel tank vent facility arrangements is provided at Appendix 2.</p>		
<b>2.3.2</b>	<b>Does the fuel tank vent line have a minimum internal diameter of 9.5mm (<math>\frac{3}{8}</math>in)?</b>	<b>R</b>
Measure the outside diameter of fuel vent lines.	The internal diameter of vent lines must be at least 9.5mm ( $\frac{3}{8}$ in).	
<p>Applicability – the internal diameter may be verified by measuring the outside diameter and estimating wall thickness.</p> <p>Applicability – where the internal diameter of a vent line is found to be less than 9.5mm and the boat is CE marked according to the Recreational Craft Directive or UKCA marked according to the Recreational Craft Regulations, Examiners should contact the BSS Office for guidance.</p>		
<b>2.3.3</b>	<b>Are the fuel tank vent line connections free of signs of leaks and in good condition, and are all vent hose connections accessible for inspection?</b>	<b>R</b>
<p>Check the accessibility of fuel tank vent hose connections, and check their condition by sight and touch.</p> <p>Check the condition of fuel tank vent pipe connections where they can be seen or reached.</p>	<p>All vent hose connections must be:</p> <ul style="list-style-type: none"> <li>• accessible for inspection; <b>and</b>,</li> <li>• secure; <b>and</b>,</li> <li>• free of signs of leaks; <b>and</b>,</li> <li>• free of signs of damage or deterioration.</li> </ul> <p>Vent pipe connections must be:</p> <ul style="list-style-type: none"> <li>• secure; <b>and</b>,</li> <li>• free of signs of leaks; <b>and</b>,</li> <li>• free of signs of damage or deterioration.</li> </ul>	
<p>Applicability – where hose connections are not accessible for inspection, Check 2.3.3 must be recorded as ‘not verified’ on your checklist, and it must be considered that the Check has not been completed until such time as their condition has been verified.</p>		
<b>2.3.4</b>	<b>Is the fuel tank vent line self-draining so that fuel is not retained, and is it free of kinks or other restrictions?</b>	<b>R</b>
<p>Check the fall of each vent line where it can be seen or reached.</p> <p>Check for any kinks or other obvious restrictions in any vent lines where they can be seen or reached.</p>	<p>Vent lines must be connected to the top of the tank and be ‘self-draining’, i.e. fall continuously from the vent outlet to the tank, or, where a swan neck is installed, from the top of the swan neck down to the vent outlet and the fuel tank connection.</p> <p>Vent lines must not be kinked or restricted.</p>	
<p>Applicability – vent lines must not have their internal bore diameter restricted to less than 9.5mm (<math>\frac{3}{8}</math>in).</p> <p>Applicability – ‘top of the tank’ means the top plate of the fuel tank or the highest part of the side of the tank.</p>		



<b>2.3.5</b>	<b>Is the material of the fuel tank vent line suitable and in good condition?</b>	<b>R</b>
Check the material and condition of vent lines which can be seen or reached. Check the markings on any vent hose.	Vent lines must not show signs of fuel leaks, damage or deterioration. Vent hose must be marked as suitable for the fuel in use or supported by an appropriate declaration.	
<p>Applicability – diesel tank vent hose in good condition may be accepted without marking or declaration provided it can be examined over its entire length.</p> <p>Applicability- hoses marked ISO 7840, ISO 8469, ISO 15540, SAE J 1527, DIN 4798 or RINA DIP/66/96 may be accepted as being suitable for use with petrol or diesel.</p> <p>Applicability – in cases where the vent hose is suitably marked, enough of the hose must be accessed in order that the Examiner can make a reasonable assessment as to its general condition.</p>		

## 2.4 Fuel tank vent outlets

<b>2.4.1</b>	<b>Does the fuel tank vent outlet, or the vent line swan neck, rise at least as high as the filling point?</b>	<b>R</b>
Check the rise of each vent line.	Fuel tank vent outlets, or the vent line swan neck must rise to a height at least that of the fuel filling point.	
<p>Applicability – where the filling point is mounted on a deck a swan neck in the vent line to the underside of the deck meets this Requirement.</p>		

<b>2.4.2p</b>	<b>Are petrol tank vent outlets fitted with a suitable proprietary flame arrestor in good condition?</b>	<b>R</b>
Check each petrol tank vent outlet for the presence of a suitable proprietary flame arrestor. Check the condition of the suitable proprietary flame arrestor(s) including the flame arresting gauze.	Petrol tank vent outlets must be fitted with a suitable proprietary flame arrestor. Suitable proprietary flame arrestors and their flame arresting gauze must be free of signs of restrictions, or other damage or deterioration.	
<p>Applicability – flame arrestor not recognised as being of suitable proprietary manufacture may be supported by satisfactory documentation. Examiners must be careful not to mistake a water tank vent outlet for a suitable proprietary flame arrestor; supporting information is provided at Appendix 2.</p> <p>Applicability – the small hole in the filler cap as provided by the original engine or fuel tank manufacturer, on fuel tanks of no more than 30 litres capacity, is deemed to meet this Requirement.</p>		

<b>2.4.2d</b>	<b>Are diesel tank vent outlets in good condition?</b>	<b>R</b>
Check the condition of each diesel tank vent outlet.	Diesel tank vent outlets must be free of signs of restrictions, or other damage or deterioration.	

<b>2.4.3</b>	<b>Is the fuel tank vent outlet in a position where no danger will be incurred from leaking fuel or escaping vapour?</b>	<b>R</b>
Check the position of each vent outlet.	Vent outlets must be clear of any potential sources of ignition and must be in a position where no danger will be incurred from leaking fuel or escaping vapour into the interior of the vessel.	
<p>Applicability – this Requirement does not apply to the following provided there is no risk of unseen spillage from the vent outlet:</p> <ul style="list-style-type: none"> <li>• historic (i.e. bona fide ex-working) diesel-engined boats (Examiners should seek guidance from the BSS Office when determining whether a boat is a bona fide ex-working boat); <b>or</b>,</li> <li>• diesel tanks, of up to a maximum capacity of 30 litres.</li> </ul> <p>Applicability – vent outlets located within open vessels such as RIBs having no accommodation and having a continuous deck or sole which is fuel-tight to the interior of the vessel, including bilge spaces, meet this Requirement.</p> <p>Applicability – diesel vent outlets within self-draining cockpits having a continuous deck or sole that are fuel-tight to the interior of the vessel, including bilge spaces, meet this Requirement.</p>		

## 2.5 Fuel tank design and condition

<b>2.5.1</b>	<b>Are non-integral fuel tanks incapable of movement under light manual force?</b>	<b>R</b>
Where enough of the tank can be reached, assess the extent of possible movement by applying light manual force to each non-integral tank.	Non-integral fuel tanks must be incapable of unintended movement under light manual force.	
<p>Examiner action – light manual force should only be applied to the main tank structure and not to tank spigots or attached fuel filler, vent, supply or return lines.</p> <p>Applicability – Examiners need not apply light manual force to fuel tanks assessed to be too heavy to move.</p> <p>Applicability – slight movement is acceptable on tanks of up to 30 litres providing there are no pipe connections to the tank and providing there is no evidence that any movement is putting strain on connected hoses or other fittings.</p> <p>Guidance for owners – although not a BSS Requirement, it is recommended that all fuel tanks are permanently secured by boat structures, brackets, straps etc, and that any existing securing arrangements are kept in good condition.</p>		

2.5.2	Are fuel tanks made of suitable materials?	R
<p>At each fuel tank check the material and check for evidence of obvious suitability.</p>	<p>Fuel tanks must not be manufactured with obviously unsuitable materials.</p> <p>Materials obviously suitable for diesel include:</p> <ul style="list-style-type: none"> <li>• aluminium alloy</li> <li>• 'CE' or 'UKCA' marked plastic</li> <li>• FRP</li> <li>• mild steel</li> <li>• stainless steel.</li> </ul> <p>Materials obviously suitable for petrol include:</p> <ul style="list-style-type: none"> <li>• aluminium alloy</li> <li>• brass</li> <li>• 'CE' or 'UKCA' marked plastic</li> <li>• stainless steel.</li> </ul>	
<p>Examiner action – Examiners must refer to Section 1 of Appendix 2 for essential information on unsuitable materials and examining plastic fuel tanks.</p> <p>Applicability – the fuel tank must be accessible enough to allow a general assessment of material. Tanks not accessible to assess the material must be recorded as 'not verified' on your checklist, and it must be considered that the Check has not been completed until such time as the suitability of the material has been verified.</p> <p>Applicability – Examiners are not required to identify whether fuel tanks are lined or otherwise internally coated. A judgement must be made as to a tank's suitability from a visual assessment of the tank's external surfaces.</p> <p>Applicability – where after assessment of the tank material its suitability cannot be verified, and where the material is not obviously unsuitable, apply the condition Checks at 2.5.3. If the condition Requirements are met mark your checklist as being a pass at 2.5.2 and 2.5.3. If the condition Requirements at 2.5.3 are not met mark your checklist as a fail at 2.5.2 and 2.5.3. This Applicability does not apply to plastic tanks; plastic tanks that are not CE or UKCA marked, or not otherwise recognised as being suitable, must be recorded as non-compliant.</p>		

<b>2.5.3</b>	<b>Are fuel tanks, including seams and openings, in good condition and free of signs of leaks?</b>	<b>R</b>
<p>Check the condition of all fuel tank surfaces, seams and openings which can be seen and reached.</p>	<p>Fuel tanks including seams and openings must be free of signs of damage or deterioration, including:</p> <ul style="list-style-type: none"> <li>• leaks; <b>or</b>,</li> <li>• heavy corrosion (including deep pitting); <b>or</b>,</li> <li>• chafing, irregular indentations or punctures on plastic tanks; <b>or</b>,</li> <li>• softening or environmental stress cracking on plastic tanks.</li> </ul> <p>All inspection and cleaning access plates and other external fittings such as fuel gauge sender units must be secured in place and free of signs of leaks.</p>	
<p>Examiner action – Examiners must refer to Section 1 of Appendix 2 for essential information on examining plastic fuel tanks.</p> <p>Applicability – the fuel tank must be accessible enough to allow a general assessment of condition. Tanks not accessible to assess condition must be recorded as ‘not verified’ on your checklist, and it must be considered that the Check has not been completed until such time as their general condition has been verified.</p> <p>Applicability – where accessible, pay particular attention to areas under dipsticks/sounding pipes for evidence of damage from dipstick ‘bounce’.</p>		

<b>2.5.4</b>	<b>Are fuel tanks within engine spaces suitably fire resistant or otherwise protected against the effects of fire?</b>	<b>R</b>
<p>Identify fuel tanks located within engine spaces.</p> <p>If present, at each non-metallic fuel tank look for the manufacturer’s plate for evidence of intrinsic fire resistance or verify this by examining any presented declaration from the manufacturer or supplier.</p> <p>At each metallic fuel tank check for signs of soft-soldered seams where these can be seen or reached.</p>	<p>Non-metallic fuel tanks must have intrinsic fire resistance of at least 2.5 minutes at 650°C or be otherwise protected from fire. Metallic tanks must not have soft-soldered seams.</p>	
<p>Examiner action – Examiners must refer to Section 1 of Appendix 2 for essential information on examining plastic fuel tanks.</p> <p>Applicability – non-metallic fuel tanks CE or UKCA marked and marked ISO 21487 may be accepted as having an intrinsic fire resistance of at least 2.5 minutes at 650°C.</p>		

<b>2.5.5</b>	<b>Are petrol tanks installed at the required distances from heat sources or protected by a heat baffle?</b>	<b>R</b>
<p>Measure the distance from any petrol tank to any engine, exhaust system or other heat source.</p> <p>Check for the presence of a fire-resistant baffle between any such petrol tank and heat source.</p>	<p>Petrol tanks must be located:</p> <ul style="list-style-type: none"> <li>• at least 100mm (4in) from general heat sources; <b>and</b>,</li> <li>• at least 250mm (10in) from a dry exhaust.</li> </ul> <p>If the distances are less than those prescribed a fire-resistant baffle in good condition must protect the tank from radiated heat.</p>	

## 2.6 Fuel gauges

2.6.1	<b>Are petrol tanks free of glass or plastic tube or strip-type fuel gauges?</b>	<b>R</b>
Check each petrol tank for glass or plastic tube or strip-type fuel gauges.		Petrol tanks must not be fitted with glass or plastic tube or strip-type fuel gauges.
2.6.2	<b>Are any glass or plastic tube or strip-type fuel gauges closely coupled to the tank, fitted with a self-closing valve and in good condition?</b>	<b>R</b>
Check each diesel tank for the provision of glass or plastic tube or strip-type fuel gauges. If provided check the installation arrangements.		Glass or plastic tube or strip-type fuel gauges must be: <ul style="list-style-type: none"> <li>• closely coupled to the tank; <b>and</b>,</li> <li>• fitted with self-closing valves at the bottom; <b>and</b>,</li> <li>• complete and free of signs of leaks and other signs of damage or deterioration.</li> </ul>
<p>Applicability – self-closing valves are not required for fuel gauges on any diesel-fuelled vessel formerly used for the commercial carriage of freight or passengers or as a tug or as an icebreaker and which is to be licensed for use as a pleasure vessel, or registered for use as a houseboat, unless used for the purposes of hire or reward. Documentary evidence of former use addressed to the BSS manager is required to enjoy this exception.</p> <p>Applicability – self-closing valves are not required on sight gauge arrangements on day tanks having a maximum capacity of up to 30 litres.</p>		
2.6.3	<b>Are all fuel gauges and level-indicators in good condition and free of signs of leaks?</b>	<b>R</b>
Check any fuel tank fuel gauge and level-indicator for condition.		Fuel gauges and fuel level-indicators: <ul style="list-style-type: none"> <li>• must be free of signs of leaks and/or signs of damage or deterioration or missing components and fixings that could lead to a leak; <b>and</b>,</li> <li>• must not have fuel behind any transparent cover.</li> </ul>
Applicability – loose or damaged gauge needles, or other such level-indicators, mounted behind any glass or transparent cover do not constitute a failure.		
2.6.4	<b>Are fuel tank openings for dipsticks closed by a fuel-tight cap or fitting?</b>	<b>R</b>
Identify any fuel tank openings intended to be used for dipsticks and check for a fuel-tight cap or fitting, and for indications of fuel leaks.		Fuel tank openings used for dipsticks must be closed by a cap or fitting and must be free of signs of leaks.

## 2.7 Petrol fuel system electrical bonding

2.7.1	<b>Are all metallic components in the petrol filling and tank system electrically bonded to earth?</b>	<b>R</b>
Check all petrol filling and tank systems for the presence of electrical bonding.	<p>Where petrol filling lines have non-conducting sections, an electrical bond between all metallic parts, e.g. tank, filling point and any intermediate hose connectors, must be fitted.</p> <p>Where the deck and hull are non-conducting, or where the filling point is non-conducting, all metallic petrol tanks, and all metallic petrol filling components, must be electrically bonded to an earth point in direct electrical contact with the surrounding water.</p>	
Guidance for owners – a bonding cable of at least 2.5mm <sup>2</sup> is recommended.		

2.7.2	<b>Are all parts of electrical bonding systems in good condition?</b>	<b>R</b>
Check the condition of the electrical bonding connections by sight or touch. Check the condition of bonding cables where they can be seen or reached.	<p>The electrical bonding system must show:</p> <ul style="list-style-type: none"> <li>• no movement at any of the connections; <b>and</b>,</li> <li>• no signs of damage or deterioration, along the cables or at their connections.</li> </ul>	
Applicability – all necessary electrical bonding connections must be seen or reached in order to be able to establish the existence of adequate bonding provision.		

## 2.8 Fuel tank connections

2.8.1	<b>Are any fuel tank drains closed with a plug or cap, or valve, which can only be opened with tools, and are the drains and their connections in good condition and free of signs of leaks?</b>	<b>R</b>
<p>Check each fuel tank for the presence of a fuel drain facility.</p> <p>Check fuel tank drains by sight and touch for:</p> <ul style="list-style-type: none"> <li>• the presence of a 'tools to remove' plug or cap on the outlet; <b>and/or</b>,</li> <li>• a 'tools to operate' shut-off valve.</li> </ul> <p>Check the condition of fuel tank drains, their connections and any valves by sight and touch.</p>	<p>If present, fuel tank drains must be closed by either:</p> <ul style="list-style-type: none"> <li>• a 'tools-to-remove' plug or cap on the outlet; <b>or</b>,</li> <li>• a 'tools-to-operate' shut-off valve at the tank connection.</li> </ul> <p>Fuel tank drains, their connections and any valves must be:</p> <ul style="list-style-type: none"> <li>• secure; <b>and</b>,</li> <li>• free of signs of leaks; <b>and</b>,</li> <li>• free of signs of damage or deterioration.</li> </ul>	
Applicability – where compliance is achieved using a plug or cap it must be of suitable proprietary manufacture and/or be metallic and it must be fixed in place by a screw mechanism which requires a tool to remove it.		

<b>2.8.2</b>	<b>Are the petrol feed line connections in lift-pump systems made to the top of the tank?</b>	<b>R</b>
<p>Check for the presence of a petrol fuel system with a lift-pump supply. If present, check all petrol feed line connections are made to the top of the tank.</p>		<p>Petrol feed lines must be connected to the top of the fuel tank on lift-pump feed systems.</p>
<p>Applicability – ‘top of the tank’ means the top plate of the fuel tank or the highest part of the side of the tank. Applicability – the Requirement also applies to petrol return lines where these are fitted.</p>		

<b>2.8.3</b>	<b>Is the petrol feed line on a gravity system fitted with a valve directly attached to the tank?</b>	<b>R</b>
<p>Check for the presence of a gravity-fed petrol installation and check for the presence of a valve in the petrol feed line directly attached to the tank.</p>		<p>The petrol feed line on gravity-fed petrol installations must be protected by a valve directly attached to the tank.</p>
<p>Applicability – a gravity-fed petrol installation is one where there is no lift-pump to move the fuel from the tank to the engine and the height of the tank is above that of the engine.</p>		

<b>2.8.4</b>	<b>Are fuel tank connections accessible for inspection?</b>	<b>R</b>
<p>Check the accessibility of tank connections by sight and touch.</p>		<p>Fuel tank connections must be accessible for inspection.</p>
<p>Applicability – this Requirement applies to all fuel supply and return line, fuel filling line, vent lines and balance line connections.</p>		

<b>2.8.5</b>	<b>Are any unused tank connections closed with a plug or cap which can only be opened with tools, and are unused connections in good condition and free of signs of leaks?</b>	<b>R</b>
<p>Where it can be seen or reached, check each fuel tank for the presence of unused connections. If present, check each unused tank connection for the presence of a ‘tools to remove’ plug or cap, and check its condition.</p>		<p>Unused tank connections must be:</p> <ul style="list-style-type: none"> <li>• closed with a ‘tools-to-remove’ plug or cap; <b>and</b>,</li> <li>• secure; <b>and</b>,</li> <li>• free of signs of leaks; <b>and</b>,</li> <li>• free of signs of damage or deterioration.</li> </ul>
<p>Applicability – each plug or cap must be of suitable proprietary manufacture and/or be metallic and must be fixed in place by a screw mechanism which requires a tool to remove it. Applicability – unused fuel lines connected to tanks must be closed with a ‘tool-to-remove’ plug or cap and be in good condition and free of signs of leaks.</p>		

## 2.9 Fuel tank balance lines

<b>2.9.1</b>	<b>Are multiple petrol tank systems free of balance lines?</b>	<b>R</b>
Check for the presence of multi-petrol tank systems and check for the presence of balance lines.		Petrol systems must not be fitted with balance lines.

<b>2.9.2</b>	<b>Are balance lines on diesel tank systems made of suitable materials and are they in good condition and free of signs of leaks?</b>	<b>R</b>
<p>Check the material of all diesel balance lines that can be seen and check for evidence of suitability.</p> <p>Check the markings on any hose used as a balance line.</p> <p>Check the condition of each balance line and its connections where they can be seen or reached.</p>	<p>Diesel system balance lines must be made of suitable materials.</p> <p>Metallic materials suitable include:</p> <ul style="list-style-type: none"> <li>• aluminium alloy</li> <li>• copper</li> <li>• mild steel</li> <li>• stainless steel</li> </ul> <p>Non-metallic materials suitable include:</p> <ul style="list-style-type: none"> <li>• FRP</li> <li>• Hose marked to denote both suitability for the fuel used, and fire resistance, to BS EN ISO 7840 or an equivalent standard.</li> </ul> <p>Diesel system balance lines must be free of signs of leaks and signs of damage or deterioration.</p>	
<p>Applicability – where after assessment of any metallic or FRP balance line material its suitability cannot be verified, and where the material is not obviously unsuitable apply the condition Checks only.</p> <p>Applicability – balance line connections must comply with the Requirements at 2.11 (Fuel line connections). If not compliant with all the Requirements at 2.11 a fault shall be recorded at 2.9.2.</p> <p>Applicability – when fuel filler hose is connected to a balance line, it must be checked in the same way as a hose permanently charged with fuel – see 2.10 and 2.11.</p>		

## 2.10 Fuel feed, return, and on-engine lines

<b>2.10.1</b>	<b>Are all fuel feed, return and on-engine pipes made of suitable materials?</b>	<b>R</b>
Check the material of all fuel feed, return and on-engine pipes that can be seen and check for evidence of suitability.	<p>Fuel pipes must be made of suitable materials.</p> <p>Suitable materials include:</p> <ul style="list-style-type: none"> <li>• aluminium alloy</li> <li>• copper</li> <li>• mild steel (for diesel only)</li> <li>• stainless steel.</li> </ul>	
<p>Applicability – where after assessment of the material its suitability cannot be verified, and where the material is not obviously unsuitable apply the condition Checks at 2.10.3. If the condition requirements are met mark your checklist as being a pass at 2.10.1 and 2.10.3. If the condition requirements at 2.10.3 are not met mark your checklist as a fail at 2.10.1 and 2.10.3.</p> <p>Applicability – the use of hose and other non-metallic components within high-pressure diesel fuel lines between injection pumps and injectors is not permitted. Where such lines are obviously not metallic or where the material type cannot be identified mark your checklist as a fail.</p> <p>Applicability – fuel lines connecting small capacity diesel containers to the cold start facility on older diesel engines are exempt from this Requirement.</p>		



<b>2.10.2</b>	<b>Are all fuel feed, return and on-engine hoses suitable for the fuel used and fire resistant?</b>	<b>R</b>
Check the marking on all fuel feed, return and on-engine hoses.	Fuel feed, return and on-engine hoses must be marked, to denote both suitability for the fuel used and fire resistance, to BS EN ISO 7840 or an equivalent standard.	
<p>Applicability – hoses marked to SAE J 1527, DIN 4798 or RINA DIP/66/96 are acceptable.</p> <p>Applicability – hose assemblies connected to diesel boilers and marked ISO 6806 can be taken as meeting this Requirement.</p> <p>Applicability – the presence of armoured or other external braiding is not evidence of hose suitability or fire resistance. Such hoses must be marked as above.</p> <p>Applicability – fuel-hose suitability may be supported by a written declaration from the hose manufacturer or supplier or, if appropriate, from the engine manufacturer/supplier or mariniser.</p> <p>Applicability – fuel lines connecting small capacity diesel containers to the cold start facility on older diesel engines are exempt from this Requirement.</p> <p>Applicability: fuel hoses in permanently installed fuel systems to diesel appliances may be to ISO 8469 (or equivalent), provided the hose and its connections are not located within an engine space.</p> <p>Applicability – fuel hoses in permanently installed fuel systems to outboard engines may be to type B1 or B2 of ISO 8469 (or be suitable proprietary outboard engine fuel hose), provided the hose and its connections are located in the open air and where any fuel spillage would drain overboard (e.g. self-draining cockpits or outboard wells not enclosed by a canopy or other cover). Open vessels such as RIBs having a continuous deck or sole that is fuel-tight to the interior of the vessel and bilge spaces, meet this Requirement.</p> <p>Supporting information on permanently installed fuel systems to outboard engines is provided at Appendix 5.</p>		

<b>2.10.3</b>	<b>Are all feed, return and on-engine pipes secure and in good condition?</b>	<b>R</b>
Check the condition of all fuel feed, return and on-engine pipes which can be seen or reached. Apply light manual force to check security of all fuel feed, return and on-engine pipes that can be reached.	Fuel feed, return and on-engine pipes must be free of signs of leaks, signs of damage or deterioration. Fuel feed, return and on-engine pipes must not move under light manual force.	

<b>2.10.4</b>	<b>Are all fuel feed, return and on-engine hoses properly supported and in good condition?</b>	<b>R</b>
Check the condition of all fuel feed, return and on-engine hoses which can be seen or reached. Check fuel feed, return and on-engine hoses where they can be seen or reached for support and protection.	All fuel feed, return and on-engine hoses must be free of signs of leaks or damage or deterioration including flaws, brittleness, cracking, abrasion, kinking and 'soft spots'. On hoses covered with metal braiding the braiding must be free of signs of damage or deterioration including corrosion and kinking. Fuel feed, return and on-engine hoses must be supported clear of anything likely to damage them, or be otherwise protected.	

<b>2.10.5</b>	<b>Do the diesel injector leak-off (spill rail) arrangements meet specified Requirements?</b>	<b>R</b>
Apply the Checking actions from Checks 2.10.1–4 and 2.11.1-3 to the diesel injector leak-off arrangements and refer to Appendix 2a if necessary.	Diesel injector leak-off (spill-rail) arrangements must meet: <ul style="list-style-type: none"> <li>• all the relevant Requirements at Checks 2.10.1–4 and 2.11.1-3;</li> <li><b>or,</b></li> <li>• one of the alternative compliance options listed in Appendix 2a.</li> </ul>	
Applicability – vintage and traditional engines designed to return the injector leak-off fuel to a catch pot are acceptable provided the catch pot is securely mounted and is free of signs of leaks and of signs of damage or deterioration. On such arrangements, there must be no signs of fuel leaks, but otherwise the fuel line to the catch pot is exempt from the BSS Requirements. Applicability – injector leak-off hoses fitted by the manufacturer within an enclosure on the engine meet this Requirement.		

## 2.11 Fuel feed, return, and on-engine fuel line connections

<b>2.11.1</b>	<b>Are all fuel line connections of the correct type and free of signs of leaks?</b>	<b>R</b>
Check the type of fuel line connections that can be seen or reached and check for signs of leaks by sight or touch.	Fuel pipe connections must be screwed, compression, cone, brazed or flanged. Fuel hose connections must be either pre-made end fittings on hose assemblies or hose clips/clamps onto hose nozzles or formed pipe-ends. Fuel line connections must be free of signs of leaks, signs of damage or deterioration.	
Applicability – the Requirement that fuel hose connections must be either pre-made end fittings on hose assemblies or hose clips/clamps onto hose nozzles or formed pipe-ends does not apply to fuel systems on liquid-fuelled appliances. On such systems hose may be connected to pipe without a formed end. In such circumstances the hose must be secured to the pipe with a clip/clamp and the connection must be free of signs of leaks, and signs of damage or deterioration. Applicability – soft-soldered joints are not acceptable. Examiners concerned that particular joints may have been made using soft solder must require the owner to provide proof that this is not the case. Applicability – injector leak-off (spill rail) arrangements having push-on connections on flexible fuel lines are acceptable for options covered by the alternative compliance options set out in Appendix 2a. Applicability – the push-fit end connections on the fuel lines connecting small capacity diesel containers to the cold start facility on older diesel engines should be considered as meeting this Requirement if the connections are free of signs of leaks. Applicability – fuel hoses in permanently installed fuel systems to outboard engines may terminate at the outboard with a proprietary quick-release self-closing connector conforming to 5.2.1.		

<b>2.11.2</b>	<b>Are fuel hose connections made with hose clips or clamps effective and in good condition?</b>	<b>R</b>
<p>Check the effectiveness and condition of all fuel hose connections made with hose clips or clamps that can be seen or reached.</p> <p>Pull using light manual force to check security of all hose connections that can be reached.</p>	<p>Fuel hose connections made with hose clips or clamps must:</p> <ul style="list-style-type: none"> <li>• be suitably sized, that is, not so oversized that the band forms an elliptical shape or so undersized that no tightness is achieved; <b>and</b>,</li> <li>• be appropriately tight, that is, not so loose that the connection can be pulled forward or back under light manual force, nor so tight that the hose is excessively pinched; <b>and</b>,</li> <li>• show no signs of damage or deterioration at the clip or clamp; <b>and</b>,</li> <li>• show no signs of damage or deterioration at the hose caused by the clips or clamps.</li> </ul>	
<p>Applicability – the light manual force Check must not be applied to injector leak-off (spill rail) arrangements having push-on connections.</p>		

<b>2.11.3</b>	<b>Are all fuel line connections, valves, fittings and other components secure?</b>	<b>R</b>
<p>Apply light manual force to check security of all fuel line connections, valves, fittings and other components that can be reached.</p>	<p>Fuel line connections, valves, fittings and other components must not move under light manual force.</p>	
<p>Applicability – at connections between pipe and hose it is acceptable for there to be some movement at the connection provided the pipe is fixed in place within 100mm of the connection and there is no movement of the pipe at its fixing point.</p>		

## 2.12 Fuel filters

<b>2.12.1</b>	<b>Are fuel filters in good condition?</b>	<b>R</b>
<p>Check the condition of all fuel filters.</p>	<p>Fuel filters must be free of signs of leaks and signs of damage or deterioration to any part of the filter assembly.</p>	
<p>Applicability – the Requirements at Section 2.12 must be applied to all forms of fuel filters.</p>		

<b>2.12.2</b>	<b>Are all fuel filters inside engine spaces fire resistant?</b>	<b>R</b>
<p>Check all fuel filters (including drain plugs) located inside engine spaces are marked or recognised as fire resistant. If not marked or recognised as being suitably fire resistant, verify this by examining any presented declaration from the manufacturer or supplier.</p>	<p>Fuel filters (including drain plugs) located inside engine spaces must have intrinsic fire resistance of at least 2.5 minutes at 650°C.</p>	
<p>Applicability – all-metal fuel filters are accepted as being sufficiently fire resistant.</p> <p>Applicability – fuel filters marked with ISO 10088 are acceptable.</p>		

## 2.13 Fuel shut-offs

<b>2.13.1</b>	<b>Is an emergency fuel shut-off installed in every fuel feed line?</b>	<b>R</b>
<p>Check the means to shut off the fuel in the fuel feed line from every fuel tank.</p>	<p>An effective emergency shut-off must be installed in all fuel feed lines. Any of the following methods are acceptable:</p> <ul style="list-style-type: none"> <li>• a manual shut-off valve as close as practical to the tank; <b>or</b>,</li> <li>• all fuel lines, including those on the engine, being above the level of the top of the tank; <b>or</b>,</li> <li>• an anti-siphon valve at the tank; <b>or</b>,</li> <li>• an electrically operated valve at the tank activated to open only during engine starting or running, provided that a manual emergency operating or bypassing device is present.</li> </ul>	
<p>Examiner action – Examiners must refer to Section 1 of Appendix 8 for essential information on examining fuel feed line shut-off valves for liquid-fuelled appliances.</p> <p>Applicability – in regard to manual shut-off valves, accessibility takes precedence over proximity to the tank.</p> <p>Applicability – if an Examiner cannot verify a claim from an owner that the emergency shut-off facility is provided by way of an anti-siphon valve or an electrically operated valve, they should contact the BSS Office for help verifying the claim.</p>		
<b>2.13.2</b>	<b>Are all fuel shut-off valves, or their means of operation, in a readily accessible position?</b>	<b>R</b>
<p>Check for the presence of fuel shut-off valves. If present, check their accessibility or the accessibility of their means of operation.</p>	<p>Fuel shut-off valves, or their means of operation, must be installed in a readily accessible position.</p>	
<b>2.13.3</b>	<b>Are all fuel shut-off valves, or their means of operation, in open view or their location clearly marked?</b>	<b>R</b>
<p>Check for the presence of fuel shut-off valves. If present, check that fuel shut-off valves, or their means of operation, are in open view with all removable lids, deck boards, curtains, doors etc. in place. If not in open view check their location is clearly marked in open view.</p>	<p>Fuel shut-off valves, or the means to operate them, must</p> <ul style="list-style-type: none"> <li>• be in open view with all removable lids, deck boards, curtains, doors etc. in place; <b>or</b>,</li> <li>• have their location clearly marked in open view.</li> </ul>	
<p>Applicability – the use of embossed tape (e.g. Dymo) is not acceptable. The marking must be legible with all lettering complete.</p>		
<b>2.13.4</b>	<b>Are petrol gravity-fed fuel lines provided with the required fuel shut-off facilities?</b>	<b>R</b>
<p>Check for the presence of a gravity-fed petrol installation. If present, check that a second shut-off valve, or a means of operating the main emergency fuel shut-off valve, can be reached from the steering position and check its accessibility.</p>	<p>Gravity-fed petrol installations must have a second shut-off valve, or a means of operating the main emergency fuel shut-off valve, in a readily accessible position within approximately 2m of the steering position.</p>	

## 2.14 Carburettors

<b>2.14.1</b>	<b>Are all non down-draught carburettors fitted with a drip tray?</b>	<b>R</b>
Check for the presence of a non down-draught type carburettor. If present, check for the presence of a drip tray.		Non down-draught carburettors must be provided with a drip tray.
Applicability – certain down-draught carburettors may also be capable of overflowing. Examiners concerned that a particular down-draught carburettor may be of an overflowing type should contact the BSS Office for verification.		

<b>2.14.2</b>	<b>Is the carburettor drip tray in good condition, free of signs of leaks, and easily emptied?</b>	<b>R</b>
Check the condition of any carburettor drip tray. Check that it is removable or fitted with an emptying facility.		Carburettor drip trays must be: <ul style="list-style-type: none"> <li>removable, or fitted with an emptying facility; <b>and</b>,</li> <li>free of signs of leaks, signs of damage or deterioration.</li> </ul>

<b>2.14.3</b>	<b>Is the carburettor drip tray fitted with effective flame arresting gauze permanently attached along all edges?</b>	<b>R</b>
Check the carburettor drip tray gauze for effectiveness by comparing it with a sample of gauze of the correct mesh. Check the condition of the gauze and the method of attachment to the tray.		Carburettor drip tray gauze must have a mesh of at least 11 wires per linear cm (28 wires per inch). Gauze must be complete and free of restrictions, damage, and must be permanently and continuously attached to the tray along all edges.

<b>2.14.4</b>	<b>Is the petrol engine air intake fitted with flame trap or air filter?</b>	<b>R</b>
Identify the air intake of petrol engines and look for the presence of a flame trap or air filter. Check the flame trap or air filter for condition and completeness where they can be seen.		Petrol engines must have a flame trap or air filter fitted to the air intake. Flame traps and air filters must show no signs of damage or deterioration, or obviously missing sections or components.
Applicability – there is no Requirement for Examiners to dismantle the air filter to establish the nature of the filter element.		

## 2.15 Engine installation

<b>2.15.1</b>	<b>Are all parts of engine mounting systems secure and in good condition?</b>	<b>R</b>
Check engine mounting systems for condition and completeness where they can be seen or reached.		Engine mounting systems must be free of signs of damage or deterioration, including: <ul style="list-style-type: none"> <li>fractured engine mounting brackets; <b>or</b>,</li> <li>loose, missing or fractured bolts or nuts; <b>or</b>,</li> <li>significant deterioration of any flexible mounts; <b>or</b>,</li> <li>heavily corroded metal bearers or rotten timber bearers.</li> </ul>
Applicability – for internal combustion engines housed in the original equipment manufacturer's cocoon, this Check applies to the cocoon's mounting system.		

<b>2.15.2</b>	<b>Are the structures and surfaces surrounding exhaust system components free of signs of heat damage?</b>	<b>R</b>
Check all structures and surrounding surfaces near all exhaust system components which can be seen for signs of heat damage.		The structures and surrounding surfaces near all exhaust system components must not show signs of heat damage such as scorching, melting or burning.
<p>Applicability – this Check covers all types of exhaust system components including those on ‘wet’ or ‘dry’ exhaust systems including those parts of ‘dry’ systems that are lagged or shielded.</p> <p>Guidance for owners – ‘Dry’ exhaust systems, or those parts of ‘wet’ exhaust systems not cooled by water, located in ‘walk through’ engine spaces or cabins/deck spaces or other areas where normal crew movement about the vessel can be anticipated, should be effectively lagged, shielded or otherwise protected by craft structures.</p>		

<b>2.15.3</b>	<b>Are all fuel system components in fixed inboard engine spaces permanently installed?</b>	<b>R</b>
Check for the presence of a fixed inboard engine. Check the type of fuel system supplying the fixed inboard engine.		All fuel system components in fixed inboard engine spaces must be permanently installed.
<p>Applicability – in the event a fixed inboard engine’s fuel supply system includes portable components, all such components and the connection between the portable fuel system and the permanently installed system must be located outside of the engine space. In addition, the point of connection of the permanently installed fuel supply to the portable fuel system must be made with a proprietary quick-release, self-closing connector. All portable fuel system components must comply with the applicable BSS Requirements at 5.2.1 and 5.2.2.</p>		

## 2.16 Steam engines

<b>2.16.1</b>	<b>Is the steam engine pressure system supported by an inspection certificate issued by a competent person?</b>	<b>R</b>
Read carefully the steam engine pressure system inspection certificate. Check the validity of the certificate and check the terminology indicates the pressure system is in a satisfactory condition.		<p>Steam engine pressure systems must be supported by an inspection certificate. Pressure system inspection certificates must:</p> <ul style="list-style-type: none"> <li>• relate to the vessel being examined; <b>and</b>,</li> <li>• be completed by a competent person; <b>and</b>,</li> <li>• indicate satisfactory condition; <b>and</b>,</li> <li>• must be less than 14 months old or within any ‘run-out’ date.</li> </ul>
Supporting information on the assessment of pressure system inspection certificates is provided at Appendix 2b.		

## 2.17 LPG engines

2.17.1	<b>Are fuel supply arrangements to LPG-fuelled propulsion engines compliant with BS EN 15609, or an equivalent standard, and are any dual-fuel petrol/LPG arrangements of an acceptable type?</b>	<b>R</b>
<p>[LPG-fuelled propulsion engines can only be checked for compliance by prior arrangement by the owner with the BSS Office].</p> <p>Check the fuel supply type to propulsion engines and identify those fuelled by LPG or dual-fuel petrol/LPG.</p>		<p>The fuel supply arrangements to LPG-fuelled propulsion engines must comply with BS EN 15609, or an equivalent standard.</p> <p>Any dual-fuel arrangements must be installed and maintained in accordance with the engine manufacturer's guidelines for marine applications.</p>
<p>Examiner action – during initial dealings with customers, Examiners should seek to establish whether the propulsion engines are fuelled by LPG. In cases where LPG-fuelled engines are identified, customers should be advised to contact the BSS Office. It will arrange for a full Examination of the vessel to be undertaken by an Examiner competent to apply BS EN 15609.</p> <p>Applicability – Examiners may establish compliance of portable LPG-fuelled generators to applicable BSS Requirements.</p> <p>Applicability – steam-propelled vessels having boilers fuelled by LPG are not covered by this Check.</p>		





## BSS Examination Checking Procedures – Part 3

### Electrical systems

There are four relevant BSS General Requirements:

- 8. All electrical systems must be designed, installed and maintained in a way that minimises the risks of explosion or of fire starting and spreading.**
- 9. All electrical systems must be capable of being safely and quickly disconnected from their power source(s) in an emergency.**
- 10. Control and emergency devices, or their means of operation, must be marked when not in clear view or when their function is not clear.**
- 11. All battery compartments containing unsealed or open-vented batteries must be adequately ventilated to prevent a build-up of a flammable mix of gases.**

### 3.1 Battery storage

<b>3.1.1</b>	<b>Are all unsealed or open-vented batteries ventilated to prevent risk of explosion through hydrogen accumulation?</b>	<b>R</b>
<p>Identify the location of all batteries.</p> <p>If batteries are stored within an engine, accommodation or other non-dedicated battery space, check that the space is ventilated.</p> <p>If batteries are stored within a dedicated battery space or box:</p> <ul style="list-style-type: none"> <li>• check if the space or box has any ventilation; <b>and</b>,</li> <li>• check the height of the ventilation provision and the route of any ducted ventilation.</li> </ul> <p>Check the ventilation pathway from all battery storage locations leads to the outside of the hull or superstructure.</p>	<p>All unsealed or open-vented batteries must be stored within a ventilated space.</p> <p>Dedicated battery spaces or boxes for unsealed or open-vented batteries must be ventilated at the top or the highest point of the sides of the space or box and any ductwork used must run horizontally or upwards.</p> <p>The ventilation pathway from all battery storage locations must lead to the outside of the hull or superstructure.</p>	
<p>Examiner action – Examiners must refer to Section 1 of Appendix 3 for essential information on recognising unsealed or open-vented batteries.</p> <p>Applicability – if batteries of a ‘sealed’ type are stored in a non-ventilated space verify that storage in unventilated spaces meets with the battery manufacturer’s recommendations by reference to presented documentation from the manufacturer.</p> <p>Applicability – ventilation pathways into accommodation spaces having fixed high-level ventilation or into canopied areas are acceptable.</p> <p>Applicability – battery covers must not allow the accumulation of hydrogen gas.</p> <p>Guidance for owners – the above are minimum Requirements and boat owners should refer to the battery manufacturer for guidance on the correct minimum ventilation specification. However, where this information is not available owners may calculate a generic minimum ventilation provision using the following formula. Ventilation (mm<sup>2</sup>) = number of cells x capacity in Ah x 1.935.</p> <p>Guidance for owners – if any batteries are connected to an alternator, or alternative battery charging source, having a maximum charge rate in excess of 2kW (approx. 150 Amps at 13.8 volts) it is strongly recommended to install a suitable fan-assisted ducted ventilation system that reflects the battery manufacturer’s recommendations.</p> <p>Guidance for owners – batteries should be located away from heat sources.</p> <p>Supporting information on recommended minimum ventilation for unsealed and open-vented batteries is provided at Appendix 3.</p>		

<b>3.1.2</b>	<b>Are batteries secure against excessive movement in any direction?</b>	<b>R</b>
<p>Check by visual assessment the extent all batteries, battery boxes, cradles, frameworks etc, can move.</p> <p>Apply light manual force to all battery boxes, cradles, frameworks etc, to verify the extent of possible movement.</p>	<p>All battery boxes, cradles, frameworks etc, must be free of signs of movement or possible movement, and must not move under the application of light manual force.</p> <p>All batteries must be incapable of movement in excess of 10mm in any direction.</p>	
<p>Applicability – restraint against vertical movement is generally required. However, batteries may be secured by means of a cradle or framework sufficient to ensure batteries remain secure under any condition up to 45° to the horizontal. Recesses, cradles or frameworks extending to half the height of the battery meet this allowance.</p>		

<b>3.1.3</b>	<b>Are battery terminals correctly insulated or protected?</b>	<b>R</b>
<p>Check for the presence of a battery cover or terminal covers.</p> <p>Check material and condition of any battery cover or terminal covers.</p>	<p>All metal parts of battery terminals and connections must be insulated or protected by battery covers or terminal covers.</p> <p>All battery covers or terminal covers:</p> <ul style="list-style-type: none"> <li>• must be made of insulating material; <b>and</b>,</li> <li>• must not allow any metal part of the terminal or connection to be exposed; <b>and</b>,</li> <li>• must be free of signs of damage or deterioration.</li> </ul>	
<p>Applicability – deck boards, locker lids, etc, made from or lined with insulating material may only be considered as battery covers where they will not be removed for any purpose other than gaining access to the batteries.</p>		

<b>3.1.4</b>	<b>Are batteries installed away from metallic petrol and LPG system components?</b>	<b>R</b>
<p>Measure the distance between battery tops and any metallic petrol or LPG system components installed above them.</p> <p>Where battery tops are installed within 300mm (12in) under metallic petrol or LPG system components, check the components for the presence of a conduit, shield or enclosure made of insulating material.</p>	<p>All battery tops must:</p> <ul style="list-style-type: none"> <li>• be at least 300mm (12in) away from all metallic petrol and LPG system components installed above them; <b>or</b>,</li> <li>• the components must be contained within a conduit, shield or enclosure made of insulating material.</li> </ul>	
<p>Applicability – all metallic petrol and LPG system components are covered by this Check including tanks, cylinders, pipes, valves, filters, connectors etc.</p> <p>Supporting information on the spacing between battery tops and metallic petrol or LPG system components is provided at Appendix 3.</p>		

## 3.2 Cable specifications and condition

<b>3.2.1</b>	<b>Are all electrical cables insulated?</b>	<b>R</b>
<p>Check all electrical cables which can be seen for the presence of outer insulation.</p>	<p>All electrical cables must be insulated.</p>	
<p>Applicability – this Check applies to both AC and DC cables.</p>		

3.2.2	Are battery cables of a sufficient current-carrying capacity?	R
Check the size of the following cables by comparing them against a typical sample cable. <ul style="list-style-type: none"> <li>• battery to battery isolator;</li> <li>• battery or battery isolator to starter solenoid;</li> <li>• battery to battery;</li> <li>• engine return to battery or battery isolator;</li> <li>• battery to bow thruster motor;</li> <li>• battery to anchor winch motor;</li> <li>• battery to inverter system (over 1000w size);</li> <li>• battery to electric-propulsion motor.</li> </ul>		The battery cables prescribed in the Checking action must have a minimum cross-sectional area of 25mm <sup>2</sup> .
<p>Applicability – outboard engines having the engine manufacturer’s original loom are not required to meet these dimensions.</p> <p>Applicability – cables between batteries and battery isolators are permitted to have a cross-sectional area of less than 25mm<sup>2</sup> where it can be confirmed that the circuit only supplies low current domestic and/or navigation equipment (e.g. lighting, fridges, pumps, radios, etc).</p> <p>Guidance for owners – the above are the minimum Requirements. Systems may call for larger cable sizes, depending upon the loads encountered.</p>		

3.2.3	Are all electrical cables free of damage or deterioration?	R
Check the condition of all electrical cable insulation and sheathing which can be seen.	All electrical cable insulation and sheathing must not show signs of damage or deterioration, including: <ul style="list-style-type: none"> <li>• overheating; <b>or</b>,</li> <li>• chafing; <b>or</b>,</li> <li>• reaction with water or fuel.</li> </ul>	
<p>Applicability – this Check applies to both AC and DC cables.</p> <p>Applicability – in the event significant overheating is seen on cable insulation and/or sheathing take the actions described in Appendix A and B.</p>		

### 3.3 Cable location

<b>3.3.1</b>	<b>Are all electrical cables supported in a safe location.</b>	<b>R</b>
<p>Check the run of all electrical cables which can be seen, and identify any structure or item of equipment likely to cause impact or abrasion damage.</p> <p>Identify any cables subject to the possibility of impact or abrasion damage and check for means of protection or support.</p> <p>Check arrangements where cables can be seen passing through bulkheads or structural members.</p> <p>Check the condition of all cable conduit, trays or trunking which can be seen.</p>		<p>All electrical cables must be:</p> <ul style="list-style-type: none"> <li>located where they will not be susceptible to impact or abrasion damage; <b>or</b>,</li> <li>supported away from any structure or item of equipment likely to cause impact or abrasion damage; <b>or</b>,</li> <li>contained in a cable conduit, tray or trunking.</li> </ul> <p>Cables passing through bulkheads or structural members must be protected against chafing damage by the use of grommets, glands, sleeves or sealant used effectively.</p> <p>Cable conduit, trays and trunking must be free of signs of overheating, or other forms of damage or deterioration.</p>
<p>Applicability – this Check applies to both AC and DC cables.</p> <p>Applicability – cables passing through wooden bulkheads or structural members and that are free of signs of chafing damage, are not subject to this Check.</p> <p>Applicability – where sheathed cables pass through bulkheads and other structural members, the sheathing should be considered as providing adequate protection as long as it is in good condition.</p>		

<b>3.3.2</b>	<b>Are all electrical cables clear of LPG and fuel pipes?</b>	<b>R</b>
<p>Check the clearance of all electrical cables which can be seen from LPG or fuel pipes.</p> <p>If cables are seen touching LPG or fuel pipes check whether the cable is sheathed with a non-conducting material.</p> <p>If a conduit, tray or trunking is seen touching an LPG or fuel pipe check whether the conduit, tray or trunking is made from a non-conducting material.</p>		<p>Electrical cables must be installed clear of LPG and fuel pipes unless the cables are sheathed with a non-conducting material.</p> <p>Cable conduit, trays or trunking touching LPG or fuel pipes must be made of non-conducting material.</p>
<p>Applicability – this Check applies to both AC and DC cables.</p>		

<b>3.3.3</b>	<b>Are spark plug leads free of damage or deterioration and properly supported?</b>	<b>R</b>
<p>Check the support and condition of spark plug leads.</p>	<p>Spark plug leads must be:</p> <ul style="list-style-type: none"> <li>free of signs of damage or deterioration; and,</li> <li>properly supported away from the engine block or cylinder head.</li> </ul>	

### 3.4 Cable connections

3.4.1	Are all battery cable connections effective and in good condition?	R
<p>For the cables listed at Check Item 3.2.2, visually check the type and condition of all the cable connections (including those at the batteries, battery isolators, and the engine/equipment, etc), where they can be seen.</p>	<p>All battery cables listed at Check Item 3.2.2 must be fitted with soldered or crimped lug connectors or other connections of suitable proprietary manufacture.</p> <p>All battery cable connections on cables listed at Check Item 3.2.2 must not show signs of damage or deterioration, including:</p> <ul style="list-style-type: none"> <li>• missing or loose components; <b>or</b>,</li> <li>• excessively exposed and/or damaged cable strands; <b>or</b></li> <li>• heat damage; <b>or</b>,</li> <li>• corrosion.</li> </ul>	
<p>Applicability – battery terminals fitted with screw clamps are acceptable if the cable strands are protected by the use of spreader plates or tinned cable ends in the terminal.</p> <p>Applicability – ‘crocodile’ type clips are not acceptable as battery connections for permanently installed cables.</p> <p>Applicability – in the event significant overheating is seen on battery cable connections take the actions described in Appendix A and B.</p>		

3.4.2	Are all electrical circuit cable connections effective and in good condition?	R
<p>Check the type and condition of all electrical circuit cable connections which can be seen.</p>	<p>All electrical circuit cable connections must not show signs of damage or deterioration, including:</p> <ul style="list-style-type: none"> <li>• missing or loose components; <b>or</b>,</li> <li>• excessively exposed and/or damaged cable strands; <b>or</b></li> <li>• heat damage; <b>or</b>,</li> <li>• corrosion.</li> </ul>	
<p>Applicability – this Check applies to both AC and DC cables.</p> <p>Applicability – in the event significant overheating is seen on circuit cable connections take the actions described in Appendix A and B.</p>		

3.4.3	Are all electrical cable connections above bilge water level or suitably protected?	R
<p>Check the position of all electrical cable connections which can be seen.</p> <p>Where cable connections are below bilge water level check for the presence of watertight enclosures marked as compliant with IP 67 or greater.</p>	<p>All electrical cable connections must be above bilge water level or be protected by a watertight enclosure at least meeting the IP 67 standard.</p>	
<p>Applicability – this Check applies to connections on both AC and DC cables.</p> <p>Applicability – the final cable connection to submersible bilge pumps and transducers or any other equipment intended for operation below bilge water level must be presumed to comply.</p> <p>Applicability – bilge water level can be established by any apparent bilge water tidemark.</p>		

### 3.5 Fuses and circuit breakers

3.5.1	Are all AC and DC fuses and circuit-breakers complete and in good condition?	R
<p>Check the completeness and condition of all circuit-breakers and fuses which can be seen.</p>	<p>Fuses and circuit breakers must not show signs of damage or deterioration, including:</p> <ul style="list-style-type: none"> <li>• being insecurely fitted; <b>or</b>,</li> <li>• missing or loose components; <b>or</b>,</li> <li>• heat damage; <b>or</b>,</li> <li>• corrosion.</li> </ul> <p>Fuse holders must contain appropriate fuses or fuse wire and not nails, silver paper, etc.</p> <p>Circuit breakers must not be held closed by the use of tape or other devices.</p>	
<p>Applicability – Examiners are encouraged to confirm during prior dealings with the owner, the location of the fuse box/distribution board and any in-line fuses, and to encourage their accessibility for Examination.</p> <p>Applicability – except on battery charge circuits, and on load circuits requiring a continuous supply which are connected directly to the battery(s), the lack of a fuse or circuit breaker on DC systems is not in itself a fail point – AC systems are subject to a check for the presence of a consumer unit or acceptable alternative, see Check 3.9.2.</p> <p>Applicability – Examiners are not to remove/unscrew fuses or fuse wire holders or remove circuit breakers. The Checking action for fuses and circuit breakers which cannot be seen without their removal should be confined to the Checks for completeness and condition.</p> <p>Applicability – in the event significant overheating is seen on fuses or circuit breakers take the actions described in Appendix A and B.</p>		

3.5.2	Are all fuse panels, boxes, holders and consumer units in good condition and complete?	R
<p>Check the condition of all fuse panels, boxes, holders and consumer units which can be seen.</p> <p>Where they are designed to have one, check all fuse panels, boxes, holders and consumer units which can be seen for the presence of lids or covers covering exposed terminals.</p>	<p>All fuse panels, boxes, holders and consumer units must:</p> <ul style="list-style-type: none"> <li>• be free of signs of damage or deterioration; <b>and</b>,</li> <li>• be fitted with a lid or cover of suitable proprietary manufacture over exposed terminals where they are designed to have one.</li> </ul>	
<p>Applicability – this Check applies to both AC and DC supplies.</p> <p>Applicability – in the event significant overheating is seen on fuse panels, boxes, holders or consumer units take the actions described in Appendix A and B.</p>		

<b>3.5.3</b>	<b>Are DC charge circuits that are connected directly to the battery(s) protected by a fuse or circuit-breaker?</b>	<b>R</b>
<p>Identify whether DC charge circuits from any of the following sources are connected directly to the battery(s), including the unswitched (battery) side of the battery isolator(s) where they can be seen:</p> <ul style="list-style-type: none"> <li>• battery charger outputs (including combination inverter/chargers); <b>or</b>,</li> <li>• solar panels; <b>or</b>,</li> <li>• wind turbines.</li> </ul> <p>If such circuits are identified check the charging equipment, and the charge circuits where they can be seen, for the presence of a fuse or circuit breaker.</p>		<p>Battery charge circuits connected directly to the battery(s), including the unswitched (battery) side of the battery isolator(s), from:</p> <ul style="list-style-type: none"> <li>• battery charger outputs (including combination inverter/chargers); <b>and</b>,</li> <li>• solar panels; <b>and</b>,</li> <li>• wind turbines.</li> </ul> <p>must be protected by a fuse or circuit-breaker.</p>
<p>Examiner action – Examiners must refer to Section 1 of Appendix 3 for essential information on charge circuits connected directly to batteries or to the unswitched side of the battery isolator(s).</p> <p>Applicability – charge circuits from engine-driven alternators, including those routed through split charge relays, diodes, etc, are not covered by this Check.</p> <p>Applicability – if the fuse or circuit-breaker protecting the specified charge circuits cannot be found in places where the circuit can be seen, mark your checklist as a fail. This is because it is extremely unlikely that the fuse or circuit-breaker will be located where the circuit is hidden.</p> <p>Guidance for owners – although not a BSS Requirement at this time, charge circuits connected to the switched (circuit/equipment) side of battery isolators should also be protected by a fuse or circuit breaker. Furthermore, charge circuits should only be connected to the switched (circuit/equipment) side of battery isolators where this is recommended by the charge equipment manufacturer and/or following guidance from a competent marine electrician.</p>		

### 3.6 Battery isolators

<b>3.6.1</b>	<b>Are suitable battery isolator(s) fitted and are they as close as practicable to the battery?</b>	<b>R</b>
<p>Check for the presence of one or more suitable battery isolators at each battery or bank of batteries.</p> <p>Check the distance of battery isolators from batteries.</p>		<p>Battery isolators of suitable proprietary manufacture must be fitted to each battery or bank of batteries.</p> <p>Battery isolators must be located as close as practicable to the batteries.</p>
<p>Applicability – accessibility takes precedence over proximity to the batteries.</p> <p>Applicability – if there are separate circuits connected to separate batteries, each of them must have a battery isolation switch. A combined-switch can be used, for example, in two battery system, where one battery is used for starting the boat's engine and the other used for domestic services.</p> <p>Applicability – solenoid operated battery isolators may be accepted as a suitable battery isolator.</p> <p>Applicability – quick-release battery terminal clamps may not be accepted as suitable battery isolators.</p>		



<b>3.6.2</b>	<b>Do all DC electrical load circuits pass through a battery isolator, or are those requiring a continuous supply otherwise protected?</b>	<b>R</b>
<p>Identify whether any DC load circuits are connected directly to the battery(s), or to the unswitched side of the battery isolator(s) where they can be seen.</p> <p>If DC electrical load circuits are found connected directly to the battery(s), or to the unswitched side of the battery isolator(s), check whether they are connected to the following equipment (which may be taken as requiring a continuous supply):</p> <ul style="list-style-type: none"> <li>• automatic bilge pumps; <b>or</b>,</li> <li>• security alarms (including marine radios); <b>or</b>,</li> <li>• fire pumps; <b>or</b>,</li> <li>• electronic navigation equipment with memories; <b>or</b>,</li> <li>• inverters, or combination inverter/chargers (DC input); <b>or</b>,</li> <li>• solenoid, on a solenoid activated battery isolator; <b>or</b></li> <li>• any other equipment where the manufacturer’s instructions indicate or specifically require direct connection to a battery, such as diesel-fired central heating boilers.</li> </ul> <p>Check electrical circuits supplying any equipment on the specified list, and which are connected directly to the battery(s) or to the unswitched side of the battery isolator(s), for the presence of a fuse or circuit-breaker, where the circuit can be seen.</p>		<p>Except those which feed equipment requiring a continuous supply, all DC electrical load circuits must pass through a battery isolator. Circuits which feed equipment requiring a continuous supply which do not pass through a battery isolator must be protected by a suitable fuse or circuit-breaker.</p>
<p>Examiner action – Examiners must refer to Section 1 of Appendix 3 for essential information on how to check for DC load circuits that do not pass through a battery isolator.</p> <p>Applicability – in cases where the cable connections to battery isolator(s) cannot be seen Examiners are recommended to make a note on their checklist accordingly, but the lack of access is not a BSS fail.</p> <p>Applicability – in cases where load circuits which do not lie in the specified list are found bypassing the battery isolator(s) Examiners may verify compliance by examining any presented declaration from the manufacturer or supplier.</p> <p>Applicability – if the fuse or circuit-breaker protecting specified equipment bypassing a battery isolator cannot be found in places where the circuit can be seen, mark your checklist as a fail. This because it is extremely unlikely that the fuse or circuit-breaker will be either located where the circuit is hidden, or be more than a short distance from the battery.</p>		

<b>3.6.3</b>	<b>Are battery isolators, or the means to operate them, in readily accessible positions?</b>	<b>R</b>
Check the accessibility of battery isolators, or the means to operate them.	Battery isolators, or their means of operation, must be installed in readily accessible positions.	



<b>3.6.4</b>	<b>Are battery isolators securely mounted and in good condition?</b>	<b>R</b>
Check the securing arrangements and condition of all battery isolators where they can be seen.	Battery isolators must be securely mounted, and not show signs of damage or deterioration, including: <ul style="list-style-type: none"> <li>• missing components; <b>or</b>,</li> <li>• heat damage.</li> </ul>	
Applicability – in the event significant overheating is seen on battery isolators take the actions described in Appendix A and B.		

<b>3.6.5</b>	<b>Is the location of all battery isolators, or the means to operate them, in open view, or their location clearly marked?</b>	<b>R</b>
Check that all battery isolators, or their means of operation, are in open view with all removable lids, deck boards, curtains, doors, etc in place. If not in open view check their location is clearly marked in open view.	Battery isolators, or the means to operate them, must: <ul style="list-style-type: none"> <li>• be in open view with all removable lids, deck boards, doors, etc in place; <b>or</b>,</li> <li>• have their location clearly marked in open view.</li> </ul>	

### 3.7 Two-wire DC systems

<b>3.7.1</b>	<b>Is the DC electrical system made up of ‘two-wire’ circuits?</b>	<b>A/R</b>
Check any DC wiring that can be seen to a suitable device such as a horn, headlamp, or navigation light for the presence of a ‘two-wire’ circuit.	Direct current (DC) electrical systems must be made up of ‘two-wire’ circuits, and must not use the boat’s structure as a circuit conductor.	
Applicability – 3.7.1 is an Advice check for privately owned and managed vessels, but is a mandatory Requirement for hire boats.		

<b>3.7.2</b>	<b>Is a low resistance return cable provided from the engine or starter motor to the battery?</b>	<b>R</b>
Identify the low resistance return cable from the engine or starter motor to the battery (or battery master switch in systems having negative switching). Apply the cable sizing Checks at 3.2.2.	A low resistance return cable (with a minimum cross-sectional area of 25mm <sup>2</sup> ) from the engine or starter motor to the battery must be provided on all installations.	

### 3.8 Shore-power and other alternating current (AC) electrical inlet and lead connections

3.8.1	Are all AC shore-power lead inlet connections of the correct type in good condition, and suitably protected from the weather?	A/R
<p>Check the type, condition and location of all AC shore-power inlet connections where they can be seen.</p>	<p>Shore-power inlet connections must be of suitable proprietary manufacture and must be a plug (male) type.</p> <p>Shore-power inlet connections must be securely fitted and free of signs of damage or deterioration including:</p> <ul style="list-style-type: none"> <li>• missing components; <b>or</b>,</li> <li>• cracked or broken components; <b>or</b></li> <li>• heat damage; <b>or</b></li> <li>• corrosion.</li> </ul> <p>Shore-power inlet connections not obviously splash-proof must not be located where they are likely to be subject to the weather or splashing.</p>	
<p>Applicability – 3.8.1 is an Advice check for privately owned and managed vessels, but is a mandatory Requirement for hire boats.</p> <p>Applicability – shore-power inlet connections marked with an IP rating (e.g. IP44) where the second figure is '4' or higher, provides acceptable evidence of suitable proprietary manufacture and splash-proof design.</p> <p>Applicability – do not disconnect shore power leads, but if present the owner should be invited to, providing they first make the system safe to do so.</p> <p>Applicability – if an obvious risk of electrocution is identified take the actions described in Appendix A.</p> <p>Applicability – in the event significant overheating is seen on inlet connections take the actions described in Appendix A and B.</p>		

3.8.2	Are all shore-power and other AC power source lead connections of a suitable type?	A/R
<p>Check the type of any shore-power lead connections where they can be seen.</p> <p>Check for the presence of any alternating current leads used to connect individual power sources (e.g. generators and inverters) to the alternating current distribution system. Where such leads are present check the type (e.g. male plug, or female socket) of the lead connections.</p>	<p>Shore-power leads must be fitted with a female type socket at the end which connects to the vessel's inlet connection.</p> <p>Alternating current leads within the vessel used to connect individual power sources to the vessel's alternating current distribution system must be fitted with a male type plug (or be permanently connected) at the end which connects to the power source, and a female type socket at the end which connects to the distribution system.</p>	
<p>Applicability – 3.8.2 is an Advice check for privately owned and managed vessels, but is a mandatory Requirement for hire boats.</p> <p>Applicability – do not disconnect alternating current leads, but if present the owner should be invited to, providing they first make the system safe to do so.</p> <p>Applicability – if an obvious risk of electrocution is identified take the actions described in Appendix A.</p>		

3.8.3	Are all shore-power and other AC power source leads and connectors in good condition?	A/R
<p>Check the condition of any shore-power and other AC power source lead cables where they can be seen.</p> <p>Check the condition of the connectors fitted to the cable/s.</p>	<p>Shore-power and other AC power source lead cables must be free of:</p> <ul style="list-style-type: none"> <li>• signs of damage or deterioration; <b>and</b>,</li> <li>• repairs.</li> </ul> <p>Shore-power and other AC power source lead connectors must be complete, secured onto the cable with no inner conductors visible, and be free of:</p> <ul style="list-style-type: none"> <li>• signs of damage or deterioration; <b>and</b>,</li> <li>• repairs.</li> </ul>	
<p>Applicability – 3.8.3 is an Advice check for privately owned and managed vessels, but is a mandatory Requirement for hire boats.</p> <p>Applicability – do not disconnect shore-power and other AC power source leads, but if present the owner should be invited to, providing they first make the system safe to do so.</p> <p>Applicability – if an obvious risk of electrocution is identified take the actions described in Appendix A.</p> <p>Applicability – in the event significant overheating is seen on shore-power leads or other AC power source leads or their connections take the actions described in Appendix A and B.</p>		

### 3.9 Alternating current (AC) systems – multiple power sources and consumer units

3.9.1	Is it impossible to connect simultaneously more than one power source to the AC distribution system?	A/R
<p>Check for the presence of one or more AC shore-power inlet connections.</p> <p>Check for the presence of additional AC power sources (e.g. generators and inverters).</p> <p>If two or more power sources are identified, visually check for the presence of one or more means of selection between all the identified power sources.</p>	<p>Only one power source may be connected to the AC distribution system at any one time.</p> <p>The male pins on shore-power inlet connections must not be 'live' when an alternative power source is connected to the alternating current distribution system.</p>	
<p>Applicability – 3.9.1 is an Advice check for privately owned and managed vessels, but is a mandatory Requirement for hire boats.</p> <p>Applicability – the Requirement for only one power source to be connected does not apply to synchronised multiple power sources. In cases where the boat owner claims that multiple power sources are synchronised but this cannot be verified, the Examiner should contact the BSS Office for guidance.</p> <p>Applicability – power source selectors may comprise of a multi-position manual switch, an electronic switch, or a single (male type) plug connector on the alternating current distribution system and a range of leads with corresponding (female) sockets attached to the individual power sources (see Check 3.8.2). It is also possible there may be more than one selection facility.</p> <p>Applicability – Examiners are only required to identify whether AC power source selector(s) are present, they are not required to establish whether the power source selector(s) prevent more than one power source being connected to the AC distribution system at any one time. Examiners must not operate power source selectors.</p> <p>Applicability – in the event a fault is identified take the actions described in Appendix A.</p>		

3.9.2	Do all AC electrical circuits pass through a consumer unit?	A/R
<p>Check, where they can be seen, that all AC electrical circuits pass through a consumer unit (also known as fuse/circuit-breaker box or distribution board).</p>	<p>All AC circuits must pass through a consumer unit.</p>	
<p>Applicability – 3.9.2 is an Advice check for privately owned and managed vessels, but is a mandatory Requirement for hire boats.</p> <p>Applicability – Examiners are encouraged to confirm during prior dealings with the owner, the location of the consumer unit(s).</p> <p>Applicability – for the purpose of this Check, residual current breakers with overcurrent protection (RCBOs) may be considered an acceptable alternative to a consumer unit.</p> <p>Applicability – in cases where the only power source is via a shore-power lead, an acceptable alternative to a consumer unit is an RCD, MCB or RCBO incorporated within the lead.</p> <p>Guidance for owners – there is no BSS Requirement for a Residual Current Device (RCD) to be incorporated within the main consumer unit or otherwise installed. However, it is strongly recommended that a Residual Current Device (RCD) is installed to provide appropriate electric shock protection on AC systems.</p>		

## BSS Examination Checking Procedures – Part 4

### Electrical propulsion systems

There is one relevant BSS General Requirement:

<b>12. All motors, controller equipment and charging equipment relating to electrical propulsion must be adequately ventilated.</b>
---

BSS General Requirements 1, 8, 9, 10 and 11 are relevant to the power supply or the securing of the engine.

#### 4.1 Electrically propelled boats

<b>4.1.1</b>	Check Item 4.1.1 is intentionally not used.	
--------------	---	--

#### 4.2 Electrical propulsion motor and controller

<b>4.2.1</b>	<b>Are all parts of the electric-propulsion motor mounting systems secure and in good condition?</b>	<b>R</b>
Check electrical-propulsion motor mounting systems for condition and completeness where they can be seen or reached. Apply light manual force to check the extent of any electric outboard motor movement.	Electrical-propulsion motor mounting systems must not show signs of damage or deterioration, including: <ul style="list-style-type: none"><li>fractured engine mounting brackets; <b>or</b>,</li><li>loose, missing or fractured bolts or nuts; <b>or</b>,</li><li>evidence of significant breakdown of any flexible mounts; <b>or</b>,</li><li>damaged, rusted or rotten motor bearers.</li></ul> Electric outboard motors must be securely mounted so that there is no movement in any direction at the mounting points.	
Applicability – the Check for condition and completeness includes mounting systems to electric outboard motors. Applicability – Examiners need not apply light manual force to electric outboard motors assessed to be too heavy to move.		

<b>4.2.2</b>	<b>Is the motor and controller equipment adequately ventilated and in good condition?</b>	<b>R</b>
<p>Check for any means to dissipate heat from the motor and controller equipment.</p> <p>Check the condition of the motor and controller equipment and the surrounding surfaces where they can be seen.</p>	<p>Electric-propulsion motor and controller equipment spaces must be adequately ventilated by:</p> <ul style="list-style-type: none"> <li>• the net volume of the space being 10 or more times greater than the volume of the equipment; <b>or</b>,</li> <li>• the provision of ventilation into the space.</li> </ul> <p>Electric-propulsion motor and controller equipment must not show signs of damage or deterioration, including:</p> <ul style="list-style-type: none"> <li>• any obviously missing components; <b>or</b>,</li> <li>• water ingress; <b>or</b>,</li> <li>• overheating on the equipment or the surrounding surfaces.</li> </ul>	
<p>Applicability – liquid-cooled electric propulsion motors, and liquid cooled controllers, are not subject to the Requirements for adequate ventilation at this Check.</p> <p>Applicability – this Check does not apply to outboard electric motors.</p> <p>Applicability – where the ventilation of the electric motor or controller equipment is found not to comply with the Requirements set out above and the boat is CE marked according to the Recreational Craft Directive or UKCA marked according to the Recreational Craft Regulations, Examiners should contact the BSS Office for guidance.</p> <p>Guidance for owners – although not a BSS Requirement, controller equipment spaces should be ventilated at high and low level to ensure the adequate dispersion of heat from the controller.</p>		

### 4.3 Battery charging equipment

<b>4.3.1</b>	<b>Is the battery charging equipment ventilated, complete and in good condition?</b>	<b>R</b>
<p>Check for any means to dissipate heat from the battery charging equipment.</p> <p>Check the condition of battery charging equipment and the surrounding surfaces where they can be seen.</p>	<p>Battery-charging equipment spaces must be adequately ventilated by:</p> <ul style="list-style-type: none"> <li>• the net volume of the space being 10 or more times greater than the volume of the equipment; <b>or</b>,</li> <li>• the provision of ventilation into the space.</li> </ul> <p>Battery-charging equipment must not show signs of damage or deterioration, including:</p> <ul style="list-style-type: none"> <li>• obviously missing components; <b>or</b>,</li> <li>• water ingress; <b>or</b>,</li> <li>• overheating on the equipment or the surrounding surfaces.</li> </ul>	
<p>Applicability – this Check does not require the removal of covers provided by the battery charging equipment manufacturer.</p> <p>Guidance for owners – although not a BSS Requirement, battery-charging equipment spaces should be ventilated at high and low level, to ensure the adequate dispersion of heat from the charger.</p>		

## BSS Examination Checking Procedures – Part 5

### Outboard and portable combustion engines, portable fuel systems and spare fuel

There are three relevant BSS General Requirements:

- 13. All portable and outboard engines and portable fuel systems must be designed, installed and maintained in a way that minimises the risks of explosion or of fire starting and spreading.**
- 14. All spare petrol must be stored in a way that minimises the risk of fire and explosion.**
- 15. All portable and outboard engines with integral petrol or LPG tanks, and all portable petrol tanks, must be stored in a way that minimises the risks of fire or explosion when not in use.**

#### 5.1 Permanently installed fuel systems supplying outboard and portable engines

<b>5.1.1</b>	<b>Do permanently installed fuel systems supplying outboard and portable combustion engines comply with the applicable BSS Requirements for the fuel supply system?</b>	<b>R</b>
	Identify permanently installed fuel systems supplying outboard and portable combustion engines. Apply the relevant Part of the BSS Examination Checking Procedures to the permanently installed fuel system.	Permanently installed fuel systems supplying outboard and portable combustion engines must be compliant with the applicable BSS Requirements of Part 2 or Part 7.
	Applicability – outboard engines supplied with fuel from permanently installed LPG systems are assessed by special arrangement with the BSS Office. See Check Item 5.5.1. Applicability – in the event an Examiner identifies a portable combustion engine other than an outboard engine (e.g. a portable LPG or petrol generator) supplied with fuel from a permanently installed fuel system the BSS Office should be contacted for guidance. Applicability – fuel hoses in permanently installed fuel systems to outboard engines may be to type B1 or B2 of ISO 8469 (or be suitable proprietary outboard engine fuel hose), provided the hose and its connections are located where any fuel spillage would drain overboard (e.g. self-draining cockpits or outboard wells). Open vessels such as RIBs having a continuous deck or sole that is fuel-tight to the interior of the vessel and bilge spaces, meet this Requirement. On such fuel system installations, the Checks at Part 2, sections 10 and 11 apply to the hose and its connections. Supporting information on permanently installed fuel systems supplying outboard engines is provided at Appendix 5.	

## 5.2 Portable fuel systems

5.2.1	Are all components of portable fuel systems of suitable proprietary manufacture?	R
<p>Check the type of all components of portable fuel systems including the tank, fuel hose and priming bulb, and hose connections.</p> <p>Where individual components cannot be identified as being of suitable proprietary manufacture from visual assessment alone, examine any presented declaration from the manufacturer or supplier.</p>	<p>Portable fuel system components must be of suitable proprietary manufacture, for example:</p> <ul style="list-style-type: none"> <li>• tanks must be intended for use with the fuel in use;</li> <li>• the maximum capacity of tanks must not exceed 30 litres, and they must be fitted with a carrying handle;</li> <li>• it must be possible to disconnect tanks from the fuel system or engine without the use of tools, in a way that prevents spillage of fuel, for removal and filling outside the vessel;</li> <li>• hoses and other fuel components must be intended for use with the fuel in use;</li> <li>• hose connections must be secured with proprietary clamps, clips or ties.</li> </ul> <p>Portable fuel system components not identified through visual assessment to be of suitable proprietary manufacture may be supported by an appropriate declaration from the manufacturer or supplier.</p>	
<p>Examiner action – Examiners must refer to Section 1 of Appendix 5 for essential information on portable fuel systems of suitable proprietary manufacture.</p> <p>Applicability – where an outboard or portable combustion engine intended to be supplied with fuel from a portable fuel system is present during an Examination, a complete portable fuel system must also be present. In such circumstances, where a complete portable fuel system is not present mark your checklist at Part 5 as ‘not verified’. It must be considered that the Part 5 Checks have not been completed until such time as a complete portable fuel system can be examined.</p> <p>Applicability – where outboard engine fuel lines across outboard wells are routed through trunking of suitable proprietary manufacture, with tools to remove connections at the engine and outboard well bulkhead, Examiners are not required to apply the Checking action to the enclosed fuel line. However, in such cases Examiners must check the trunking for signs of fuel leaks. A fuel leak should be recorded as a non-compliance at Check 5.2.2.</p> <p>Applicability – In the event an Examiner identifies a portable fuel system supplying a permanently installed inboard engine, refer to Check 2.15.3.</p>		

5.2.2	Are all components of portable fuel systems complete and in good condition?	R
<p>Check the completeness and condition of all portable fuel system components including the tank, fuel hose and priming bulb, and hose connections by sight and touch.</p> <p>Check the completeness and condition of support structures and fixings on transom-mounted tank arrangements where they can be seen or reached.</p>	<p>Portable fuel system components must be complete including the fuel tank cap, the hose, and hose clamps/clips/ties.</p> <p>Components of portable fuel systems must be free of:</p> <ul style="list-style-type: none"> <li>• fuel leaks; <b>and</b>,</li> <li>• signs of damage or deterioration; <b>and</b>,</li> <li>• signs of repair.</li> </ul> <p>The support structures and fixings on transom-mounted tank arrangements must be complete and free of signs of damage or deterioration.</p>	
<p>Examiner action – Examiners must refer to Section 1 of Appendix 5 for essential information on damage or deterioration of portable fuel systems components.</p> <p>Applicability – all external surfaces and seams on components, including tank undersides, should be examined.</p>		



### 5.3 Spare fuel containers and spare portable petrol tanks

5.3.1	<b>Are all spare fuel containers in good condition?</b>	<b>R</b>
Check the condition of spare fuel containers by sight and touch.	All spare fuel containers must be free of: <ul style="list-style-type: none"> <li>• fuel leaks; <b>and</b>,</li> <li>• signs of damage or deterioration; <b>and</b>,</li> <li>• signs of repair.</li> </ul>	
<p>Examiner action – Examiners must refer to Section 1 of Appendix 5 for essential information on damage or deterioration of spare fuel containers.</p> <p>Applicability – the condition of any spare portable petrol tank is covered at Check 5.2.2.</p> <p>Applicability – this Check covers spare petrol and spare diesel containers.</p>		

5.3.2	<b>Are all spare petrol containers suitable for the purpose?</b>	<b>R</b>
Check the markings on all spare petrol containers.	Spare petrol containers must be marked as suitable for the purpose. Markings must be in an indelible form and legible and include: <ul style="list-style-type: none"> <li>• the words 'PETROL' and 'HIGHLY FLAMMABLE';</li> <li>• the capacity marked in litres or gallons.</li> </ul> Individual spare petrol containers made from plastic must have a marked capacity of no more than 10 Litres. Individual spare petrol containers made from metal must have a marked capacity of no more than 20 Litres.	
<p>Applicability – the suitability of any spare portable petrol tank is covered at Check 5.2.1.</p> <p>Guidance for owners – the marked capacity of spare petrol containers allows for the expansion of fuel with changes in temperature; boat owners should be careful not to overfill containers beyond their marked capacity.</p> <p>Guidance for owners – to be compliant with the Petroleum (Consolidation) Regulations 2014 boat owners must ensure all portable petrol storage containers are legibly and indelibly marked/labelled with:</p> <ol style="list-style-type: none"> <li>i) an appropriate hazard warning sign; <b>and</b>,</li> <li>ii) manufacturer's name; <b>and</b>,</li> <li>iii) the date and month of manufacture.</li> </ol> <p>The Regulations apply to all boat owners and it is the responsibility of individual boat owners to ensure compliance.</p> <p>Supporting information on the Petroleum (Consolidation) Regulations 2014 is provided at Appendix 5.</p>		

<b>5.3.3</b>	<b>Are all spare petrol containers, and any spare portable petrol tank, limited to the permitted number and capacity?</b>	<b>R</b>
<p>Check the number of spare petrol containers and check their individual and combined marked capacity. Check for the presence of a spare portable petrol tank and check its marked capacity.</p>	<p>The number and capacity of spare petrol containers, and any spare portable petrol tank, must be limited to a total of 30 litres using one of the following options:</p> <ul style="list-style-type: none"> <li>• Only one spare portable petrol tank with a marked capacity of no more than 30 litres; <b>or</b>,</li> <li>• One spare portable petrol tank with a marked capacity of no more than 30 litres (which the boat owner may fill up to 20 litres) <b>and</b> up to two spare petrol containers with an individual or combined marked capacity of no more than 10 litres; <b>or</b>,</li> <li>• Two spare petrol containers with a combined marked capacity of no more than 30 litres.</li> </ul>	
<p>Applicability – spare portable petrol tanks are those not connected to the engine.  Applicability – Examiners are not required to measure or estimate the actual capacity of petrol in any spare portable petrol tank or container.  Applicability – the carriage of spare diesel is not restricted by volume.  Guidance for owners – The Petroleum (Consolidation) Regulations 2014 stipulate that the amount of spare petrol carried on a boat is limited to a maximum of 30 litres. The Regulations apply to all boat owners and it is the responsibility of individual boat owners to ensure compliance.</p>		

<b>5.3.4</b>	<b>Are all spare petrol containers and any spare portable petrol tank, stored to ensure that any leaking fuel or escaping vapour will not enter the interior of the vessel?</b>	<b>R</b>
<p>Check the storage arrangements of spare petrol containers.  Check the storage arrangements of any spare portable petrol tank.</p>	<p>Spare petrol containers, and any spare portable petrol tank, must be stored in:</p> <ul style="list-style-type: none"> <li>• an open location complying with the open location specifications at Check item 7.1.1; <b>or</b>,</li> <li>• a locker complying with the Requirements at the Check items in sections 7.2 to 7.5.</li> </ul>	
<p>Applicability – where the stowage arrangements for spare petrol containers, and any spare portable petrol tank, are found not to comply with this Requirement, but the vessel is CE marked according to the Recreational Craft Directive or UKCA marked according to the Recreational Craft Regulations, Examiners should contact the BSS Office for guidance.</p>		

## Outboard and portable combustion engines

<b>5.4.1</b>	<b>Are all outboard and portable combustion engines free of fuel leaks?</b>	<b>R</b>
Check for the presence of leaking fuel on or around all outboard and portable combustion engines by sight and touch.		Outboard and portable combustion engines must be free of fuel leaks.
Applicability – this Check covers all outboard and portable combustion engines, including such items as chainsaws, but when applying the Checking action Examiners are not required to remove the manufacturer’s outboard covers or generator hush covers.		
<b>5.4.2</b>	<b>Are all outboard and portable combustion engines with integral petrol tanks or LPG cartridges stored to ensure that leaking fuel or escaping vapour will not enter the interior of the vessel?</b>	<b>R</b>
Check the storage arrangements of outboard and portable combustion engines with integral petrol tanks or LPG cartridges.	Outboard and portable combustion engines with integral petrol tanks or LPG cartridges must be stored in: <ul style="list-style-type: none"> <li>• an open location complying with the open location specifications at Check item 7.1.1; <b>or</b>,</li> <li>• a locker complying with the Requirements at the Check items in sections 7.2 to 7.5.</li> </ul>	
Applicability – this Check only applies to outboard and portable combustion engines with integral petrol tanks, or LPG cartridges, that are being stored at the time of the Examination. Engines that are running or connected (e.g. outboards mounted on the craft’s transom, or portable generators connected to the craft’s electrical system) at the time of the Examination are not subject to this Check.		
Applicability – where the stowage arrangements for outboard and portable combustion engines with integral petrol tanks or LPG cartridges not in use are found not to comply with this Requirement, but the vessel is CE marked according to the Recreational Craft Directive or UKCA marked according to the Recreational Craft Regulations, Examiners should contact the BSS Office for guidance.		
<b>5.4.3</b>	<b>Are outboard engine mounting systems in good condition?</b>	<b>R</b>
Check the condition of outboard engine mounting systems where they can be seen or reached.  Assess the extent of any movement by applying light manual force to the outboard engine.	Outboard engine mounting systems must be free of signs of damage or deterioration.  Outboard engines must be securely mounted so that there is no movement in any direction at the mounting points.	
Applicability – Examiners need not apply light manual force to outboards assessed to be too heavy to move.		

## LPG-fuelled outboard propulsion engines

5.5.1	<b>Do the fuel supply arrangements to LPG-fuelled outboard engines comply with BS EN 15609 or equivalent standard and are any dual-fuel petrol/LPG arrangements of an acceptable type?</b>	<b>R</b>
<p>[LPG-fuelled outboard engines can only be checked for compliance by prior arrangement by the owner with the BSS Office].</p> <p>Check the fuel supply type to outboard engines and identify those fuelled by LPG or dual-fuel petrol/LPG.</p>		<p>The fuel supply arrangements to LPG-fuelled outboard engines must comply with BS EN 15609 or an equivalent standard.</p> <p>Any dual-fuel arrangements must be installed and maintained in accordance with the engine manufacturer's guidelines for marine applications.</p>
<p>Applicability – Examiners should seek to establish engines fuelled by LPG during initial dealings with customers and in cases where LPG fuelled outboard engines are identified customers should be advised to contact the BSS Office who can arrange for an Examiner competent to apply BS EN 15609 to undertake a full Examination of the boat.</p> <p>Applicability – all Examiners may determine compliance of portable LPG-fuelled generators, and outboard engines powered solely by LPG cartridges, to applicable BSS Requirements.</p>		

## BSS Examination Checking Procedures – Part 6

### Fire Extinguishing, Escape and Carbon Monoxide Alarms

There are two relevant BSS General Requirements:

**16. All vessels must carry specified fire fighting equipment.**

**17. All fire fighting equipment must be maintained in good condition and kept readily accessible for safe use in an emergency.**

#### 6.1 Portable fire extinguishers

6.1.1	Are the correct number of suitable portable fire extinguishers provided, and do they have the correct combined fire ratings?	R
<p>Identify all portable fire extinguishers on board.</p> <p>Check all portable fire extinguishers for their individual fire ratings, accredited third-party certification marks, and condition.</p>	<p>The minimum number of suitable portable fire extinguishers and their minimum combined fire ratings must be as prescribed in the following table.</p> <p>To be considered as suitable, portable fire extinguishers must:</p> <ul style="list-style-type: none"> <li>• have an individual fire rating of 5A/34B or greater; <b>and</b>,</li> <li>• be marked with at least one accredited third-party certification mark; <b>and</b>,</li> <li>• not show any of the following indicators of poor condition:               <ul style="list-style-type: none"> <li>– missing safety pin;</li> <li>– dents; gouges; significant rust or other form of corrosion;</li> <li>– perished hose;</li> <li>– pressure gauge (where fitted) indicator in the ‘red’ sector;</li> <li>– signs of damage or deterioration to trigger assembly, including deterioration caused by ultraviolet light and heat.</li> </ul> </li> </ul> <p>The minimum number of suitable portable fire extinguishers may be reduced by a maximum of one 5A/34B rated extinguisher where the vessel has either no internal combustion engines, or no fuel-burning appliances.</p>	
	<p style="text-align: center;"><b>Length of vessel</b></p>	<p style="text-align: center;"><b>Minimum number</b></p>
<p style="text-align: center;">Under 7m (23ft)</p>	<p style="text-align: center;">2</p>	<p style="text-align: center;"><b>Minimum combined fire rating</b></p> <p style="text-align: center;">10A/68B</p>
<p style="text-align: center;">7–11m (23–36ft)</p>	<p style="text-align: center;">2</p>	<p style="text-align: center;">13A/89B</p>
<p style="text-align: center;">Over 11m (36ft)</p>	<p style="text-align: center;">3</p>	<p style="text-align: center;">21A/144B</p>
<p>Examiner action – Examiners must refer to Section 1 of Appendix 6 for essential information on accredited third-party certification marks for portable fire extinguishers.</p> <p>Examiner action – Examiners are not required to check the standard to which extinguishers have been manufactured. Extinguishers carrying one of the accredited third-party certification marks may have been manufactured to either the previous British Standard BS 5423 or the current standard BS EN3.</p> <p>Applicability – a portable fire extinguisher having past the manufacturer’s warranty date is not an indicator of poor condition.</p> <p>Applicability – portable fire extinguishers manufactured prior to 1980 may not have fire ratings marked on the extinguisher. In cases where the boat owner claims such an extinguisher has been previously accepted by the BSS as compliant under a navigation authority’s former requirements, and the extinguisher is found to carry an accredited third-party certification mark and be in good condition, the Examiner should contact the BSS Office.</p> <p>Applicability – fuel-burning appliances include those fuelled by LPG, diesel, paraffin, spirit and solid fuels. Supporting information on portable fire extinguishers is provided at Appendix 6.</p>		

<b>6.1.2</b>	<b>Are portable fire extinguishers distributed around the vessel in readily accessible and safe locations adjacent to escape routes?</b>	<b>R</b>
Check the accessibility and location of the portable fire extinguishers identified as contributing to the required complement at 6.1.1.	<p>Portable fire extinguishers must be readily accessible.</p> <p>Portable fire extinguishers must be distributed around the vessel adjacent to escape routes.</p> <p>Portable fire extinguishers must not be mounted in a position that requires the user to reach over a cooking appliance.</p>	
<p>Applicability – ‘adjacent to escape routes’ means a location on the way out from the accommodation space.</p> <p>Applicability – the location of any fixed portable fire extinguisher brackets may be used to determine the normal location of any extinguishers found lying loose at the time of an Examination.</p> <p>Guidance for owners – extinguishers are best placed on escape routes to allow occupants to decide whether it is safe to fight a fire or escape.</p> <p>Guidance for owners – although not a BSS Requirement, it is strongly recommended that portable fire extinguishers are mounted on fixed brackets.</p>		

<b>6.1.3</b>	<b>Are all portable fire extinguishers in open view or their location clearly marked?</b>	<b>R</b>
<p>Identify the location of all portable fire extinguishers identified as contributing to the required complement at 6.1.1.</p> <p>Where portable fire extinguishers are not in open view with all removable lids, doors, curtains etc in place, check for the presence of a label in open view indicating their location.</p>	<p>Portable fire extinguishers, must:</p> <ul style="list-style-type: none"> <li>• be in open view with all removable lids, doors, curtains etc in place; <b>or</b>,</li> <li>• have their location clearly marked by a label in open view.</li> </ul>	
<p>Guidance for owners – the preferred label may be available from local chandlers, internet based suppliers, builders merchants, hardware and DIY stores and has a red background and white image (or off-white luminous) extinguisher. Examples of proprietary designs are shown here.</p> <div style="display: flex; justify-content: space-around; align-items: center;">  </div>		

## 6.2 Fire blankets

6.2.1	If the vessel has permanently installed cooking facilities, is a fire blanket of the correct specification provided?	R
<p>Check for the presence of permanently installed cooking facilities and, if present, check for the provision of a fire blanket.</p> <p>Check any markings on the fire blanket container.</p>	<p>If permanently installed cooking facilities are present a fire blanket marked to indicate conformity to BS EN 1869, or to BS 6575, must be provided.</p>	
<p>Applicability – permanently installed cooking facilities are those which would require tools to disconnect and/or remove them. Microwave ovens are not permanently installed cooking facilities in the context of this Check.</p> <p>Applicability – if no markings are present on the fire blanket container, conformity to the listed standards may be supported by the boat owner or their representative removing the blanket and confirming the blanket itself is marked. Conformity may also be supported by a written declaration from the blanket manufacturer or supplier.</p> <p>Applicability – occasional use of solid fuel stoves for cooking does not require the provision of a fire blanket. In cases where a solid fuel stove is the only potential permanently installed cooking facility Examiners should establish from the boat owner or their representative whether the stove is used for cooking on a regular basis.</p> <p>Supporting information on fire blankets, including manufacturing standards is provided at Appendix 6.</p>		

6.2.2	Is the fire blanket located close to the main cooking appliance in a safe and ready-to-use location?	R
<p>Check the location of the fire blanket.</p>	<p>Fire blankets must be located in a readily accessible position within approximately 2m of the main cooking appliance, and not mounted in a position that requires the user to reach over the cooking appliance.</p>	
<p>Applicability – the main cooking appliance should normally be taken as the hob.</p> <p>Guidance for owners – although not a BSS Requirement on privately owned and managed vessels, it is strongly recommended that fire blanket mountings should be fixed permanently in position to allow rapid access and use.</p>		

## 6.3 Emergency escape

6.3.1	Is the vessel provided with adequate means of escape?	A/R
<p>Check each accommodation space for the means to escape.</p> <p>Measure the minimum dimensions of clear openings used as a means of escape such as hatches, windows or ports.</p> <p>If a fixed window or port is designated an escape route, check that a means of 'breaking-out' is present.</p>	<p>Each accommodation space must have at least two means of escape.</p> <p>The minimum clear opening for a means to escape is 0.18 m<sup>2</sup>.and all openings must accommodate a 380mm diameter circle.</p> <p>A means of 'breaking out' any fixed window or port designated as an escape route must be stored adjacent to it.</p>	
<p>Applicability – 6.3.1 is an Advice check for privately owned and managed vessels, but is a mandatory Requirement for hire boats.</p> <p>Applicability – individual accommodation spaces (cabins), with one door opening into a fore-aft passageway need not have a second means of escape so long as the passageway allows escape at each end.</p> <p>Applicability – where a hire boat is CE marked according to the Recreational Craft Directive or UKCA marked according to the Recreational Craft Regulations but there are not two means of escape from each accommodation space Examiners should contact the BSS Office for guidance.</p> <p>Guidance for owners – on boats where a means of escape is locked from the outside, it should remain unlocked at all times when the boat is in use. Furthermore, means of escape should never be obstructed, particularly from outside the accommodation space (e.g. by storing items within the forward well deck on a narrowboat).</p> <p>Guidance for owners – avoid cutting or removing of structural members, e.g. deck beams, frames or stiffeners, to achieve a second means of escape.</p> <p>Guidance for owners – if a window or hatch is the secondary means of escape, if one is not already fitted, owners are guided to fit a proprietary label to help people not familiar with the craft to escape in the event of an emergency.</p> <p>Supporting information on means of escape is provided at Appendix 6.</p>		



## 6.4 Carbon monoxide alarms

6.4.1	If the vessel has one or more accommodation space(s), are the correct number of carbon monoxide alarms provided?	R
<p>Identify the presence of one or more accommodation space(s).</p> <p>If present, check for the presence and location of carbon monoxide alarm(s).</p> <p>Check by visual assessment and, if necessary, measure the distance between carbon monoxide alarm(s) and any door that links accommodation spaces.</p>	<p>All vessels having one or more accommodation space(s) must be provided with at least one carbon monoxide alarm.</p> <p>A carbon monoxide alarm must be located within 10m of any door that links accommodation spaces.</p>	
<p>Examiner action – Examiners must refer to Section 1 of Appendix 6 for essential information on measuring the distance between a carbon monoxide alarm and any door that links accommodation spaces.</p> <p>Applicability – where there is only a single, open-plan accommodation space only one carbon monoxide alarm is required irrespective of the size of the space.</p> <p>Guidance for owners – this is a minimum safety requirement, intended to provide a warning that is audible throughout the boat, related to carbon monoxide entering the boat from outside sources. For the best protection from carbon monoxide entering the boat from sources outside and inside the boat follow the carbon monoxide alarm manufacturer’s or supplier’s advice about the number and placement of alarms as far as the space and nature of the boat allow. Make sure alarms are audible to all craft occupants. More information about staying safe from carbon monoxide on boats is available at <a href="http://www.boatsafetyscheme.org/co">www.boatsafetyscheme.org/co</a> and within the CoGD/EM/BSS CO Safety on Boats leaflet.</p> <p>Supporting information on carbon monoxide alarms is provided at Appendix 6.</p>		

6.4.2	If any solid fuel stoves are installed, and if the vessel has berths present within any accommodation space, is a carbon monoxide alarm provided within the same accommodation space(s) as the solid fuel stove(s)?	A/R
<p>Identify the presence of any solid fuel stove and whether berths are present within any accommodation space.</p> <p>If any solid fuel stove(s) and berths within any accommodation space(s) are present, check for the presence and location of carbon monoxide alarm(s).</p>	<p>All vessels having one or more solid fuel stove(s) installed, and where berths are present within one or more accommodation space(s), must be provided with a carbon monoxide alarm within each accommodation space that contains a solid fuel stove.</p>	
<p>Applicability – 6.4.2 is an Advice check for privately owned and managed vessels, but is a mandatory Requirement for hire boats.</p> <p>Applicability – the provision of a carbon monoxide alarm(s) in support of the Requirement at Check 6.4.2 does not have to be in addition to the provision at Check 6.4.1. Depending on the configuration of the accommodation spaces (see 2nd Requirement at Check 6.4.1) one correctly located alarm might be all that is required to comply with Checks 6.4.1 and 6.4.2.</p>		

<b>6.4.3</b>	<b>Are carbon monoxide alarms in open view and of a suitable type?</b>	<b>R</b>
<p>Where one or more carbon monoxide alarms have been found to be necessary at Checks 6.4.1 and/or 6.4.2, check the location of each required alarm.</p> <p>Check the markings on each required carbon monoxide alarm.</p> <p>Identify the test function button on each required carbon monoxide alarm.</p>	<p>Carbon monoxide alarms must be in open view with all cabin doors, cupboard doors, curtains and loose furniture etc in place.</p> <p>Carbon monoxide alarms must be marked as being certified by an accredited third-party certification body to BS EN 50291 or equivalent.</p> <p>Carbon monoxide alarms must be provided with a test function button.</p>	
<p>Examiner action – Examiners must refer to Section 1 of Appendix 6 for essential information on accredited third-party certification marks for carbon monoxide alarms.</p> <p>Applicability – the main accredited third-party certification bodies in the UK are BSI and LPCB. For the following makes of carbon monoxide alarm accredited third-party certification to BS EN 50291 can be assumed – BRK, Dicon, Ei Electronics, Fire Angel, FireHawk Alarms, First Alert, Honeywell and Kidde. For other makes, removing the alarm from its base may be necessary to view labels and approval marking on the base. Permission for removal should be sought from the owner (or representative). Documentary evidence of accredited third-party certification to BS EN 50291 is acceptable.</p> <p>Guidance for owners – although not a BSS Requirement, carbon monoxide alarms marked to the ‘BS EN 50291-2’ are the best choice for boats. They have been tested to meet the more onerous conditions found in boats.</p> <p>Supporting information on accredited third-party certification is provided at Appendix 6.</p>		

<b>6.4.4</b>	<b>Are carbon monoxide alarms in good condition?</b>	<b>R</b>
<p>Where one or more carbon monoxide alarms have been found to be necessary at Checks 6.4.1 and/or 6.4.2, visually check the condition of each required carbon monoxide alarm.</p> <p>Operate the test function button on each required carbon monoxide alarm.</p>	<p>Carbon monoxide alarms must be in good general condition, and must not show signs of any of the following indicators of poor condition:</p> <ul style="list-style-type: none"> <li>• damage or deterioration to the body of the alarm or the fixing mechanism;</li> <li>• having past any manufacturer’s express replacement date;</li> <li>• failing the test function test.</li> </ul>	
<p>Applicability – Examiners are not required to open up alarms to check for internal damage or deterioration or for manufacturer’s express replacement dates.</p> <p>Applicability – some CO alarms have a manufacturer’s label stating, for example, ‘Replace 10 years after installation’ and if the installation date has not been added to the label, then the express replacement date should be taken as 10 years after the stated manufacturing date.</p>		

**BSS Examination Checking Procedures – Part 7**  
**Liquefied Petroleum Gas (LPG) systems**

There are seven relevant BSS General Requirements:

- 18. All LPG systems must be designed, installed and maintained in a way that minimises the risks of explosion or of fire starting and spreading.**
- 19. All LPG containers and high-pressure components must be secured in a position where escaping gas does not enter the interior of the vessel.**
- 20. All LPG systems must be designed, installed and maintained to ensure gas-tight integrity.**
- 21. All LPG system connections and flexible hoses must be accessible for inspection.**
- 22. All LPG control and shut-off devices, or the means to operate them must be readily accessible.**
- 23. LPG shut-off valves, or their means of operation, must be marked when not in clear view or when their function is not clear.**
- 24. All LPG systems must have a suitable means to test that the system is gas-tight.**

**7.1 LPG cylinder storage**

<b>7.1.1</b>	<b>Are all cylinders and cartridges stored in a position where any escaping LPG vapour will be directed safely overboard?</b>	<b>R</b>
<div style="display: flex; justify-content: space-between;"> <div style="width: 45%; padding-right: 10px;"> <p>Check for the presence of any cylinders or cartridges. If present, check whether their location is either in a cylinder locker, a housing, or an open location.</p> <p>If located in a cylinder locker apply the relevant Check Items at sections 7.2-7.5.</p> <p>If located in a cylinder housing apply the relevant Check Items at sections 7.2 - 7.4.</p> <p>If cylinders or cartridges are to be examined as being in an 'open location', check:</p> <ul style="list-style-type: none"> <li>• for any barriers that might prevent escaping LPG vapour flowing overboard unimpeded; <b>and</b>,</li> <li>• for any openings into the interior of the vessel, or any source of ignition, within 0.5m distance; <b>and</b>,</li> <li>• if the cylinders or cartridges are in a cockpit, determine if the cockpit is 'self-draining' as set out in section 1 of Appendix 7.</li> </ul> </div> <div style="width: 50%; padding-left: 10px;"> <p>All cylinders and cartridges, whether full, part full or empty must be stored either:</p> <ul style="list-style-type: none"> <li>• in a cylinder locker complying with the relevant Requirements of the Check Items in sections 7.2-7.5; <b>or</b>,</li> <li>• in a cylinder housing complying with the relevant Requirements at Check Items 7.2 - 7.4; <b>or</b>,</li> <li>• in an open location.</li> </ul> <p>To be accepted as being stored in an 'open location' cylinders and cartridges must:</p> <ul style="list-style-type: none"> <li>• be in a position where any escaping LPG vapour would flow overboard unimpeded; <b>and</b>,</li> <li>• be where there is no opening into the interior of the vessel, or any source of ignition, within 0.5m distance.</li> </ul> <p>For cylinders or cartridges to be accepted as being in an 'open location' in a cockpit, the cockpit must comply with the 'self-draining' specifications set out in section 1 of Appendix 7.</p> </div> </div>		
<p>Examiner action – Examiners must refer to section 1 of Appendix 7 for essential information on 'self-draining' cockpits (including well decks and other types of recessed deck).</p> <p>Examiner action – Examiners must refer to section 1 of Appendix 7 for essential information on measuring the minimum separation between cylinders in the open and openings into the interior of the vessel or sources of ignition.</p> <p>Applicability – sources of ignition include open-flame or spark-inducing equipment. Solenoid LPG system shut-off valves of suitable proprietary manufacture should be presumed not to be a source of ignition. Outboard motors within 0.5m of cylinders are not to be considered a source of ignition.</p> <p>Supporting information on the difference between lockers and housings is provided at Appendix 7.</p>		

<b>7.1.2</b>	<b>Are all self-contained portable LPG appliances stored so that any escaping LPG vapour will be directed safely overboard?</b>	<b>R</b>
<p>Check for the presence of self-contained portable appliances having cylinders or cartridges attached. If present, apply Check Item 7.1.1</p>		<p>All self-contained portable appliances having cylinders or cartridges attached must be stored in accordance with the Requirements of Check Item 7.1.1.</p>
<p>Applicability – this Check applies to camping-style appliances but not items such as refillable butane gas hob lighters. Guidance for owners – self-contained portable appliances should never be used on board boats as during use there is a risk of fire and/or explosion. Supporting information on self-contained portable appliances is provided at Appendix 7.</p>		

## 7.2 LPG cylinder locker and housing LPG-tightness

<b>7.2.1</b>	<b>Is the cylinder locker, up to the level of the top of the cylinder valves or other high-pressure components, free of any path for escaping LPG vapour to enter the interior of the vessel?</b>	<b>R</b>
<p>Determine the level of the top of the cylinder valves, or other high-pressure components where these are located higher. Determine the height of the cylinder locker sides. Determine which parts of the locker structure if holed or damaged could create a path for escaping LPG vapour to enter the interior of the vessel. Visually check the condition of the internal surfaces and seams of all cylinder lockers. Visually check the condition of the external surfaces and seams of all cylinder lockers where they can be seen.</p>		<p>The sides of every cylinder locker must extend at least up to the level of the top of the cylinder valves, or other high-pressure components where these are higher. Up to the level of the top of the cylinder valves, or other high-pressure components where these are higher, the bottom, sides, and seams of every cylinder locker must be free of any:</p> <ul style="list-style-type: none"> <li>• holes, e.g. caused by drilling, rust or cutting; <b>or</b>,</li> <li>• cracks, splits or de-laminations; <b>or</b>,</li> <li>• missing or damaged welds at seams; <b>or</b>,</li> <li>• other signs of damage or deterioration...</li> </ul> <p>... that can be identified by visual examination to penetrate the locker to the interior of the vessel.</p>
<p>Examiner action – prior to checking the condition of cylinder lockers Examiners must ensure all loose portable items are removed. Examiner action – where a part of the locker is obstructed, e.g. by the cylinders themselves, a false base or mat, or ponded water, then the Check cannot be completed until the obstruction has been removed, moved aside or cleared. Examiners should not disconnect cylinders connected to the LPG system, but where cylinders prevent the condition of the locker being verified the Check cannot be completed until the cylinders have been moved to allow access. Lockers not accessible enough to allow an assessment of condition must be recorded as 'not verified' on your checklist, and it must be considered that the Check has not been completed until such time as their condition has been verified. Applicability – hatches and any similar temporary openings, however constructed or sealed, are not permitted within the area of cylinder lockers covered by this Check. Guidance for owners – locker corrosion may lead to a leak path for LPG vapour to enter the interior of the vessel. Cylinder lockers should be maintained in good condition.</p>		

<b>7.2.2</b>	<b>Are the sealing arrangements on LPG pipework exiting the cylinder locker of the correct type to ensure LPG-tightness and in good condition?</b>	<b>R</b>
<p>Visually check the position, type and condition of sealing arrangements on LPG pipework exiting cylinder lockers.</p> <p>Where the pipework exits a locker below the highest point of the high-pressure components apply light manual force to the pipework and check for signs of movement at the sealing arrangement.</p>	<p>LPG pipework that exits cylinder lockers below the highest point of the high-pressure stage components must be sealed by either:</p> <ul style="list-style-type: none"> <li>• a bulkhead fitting; <b>or</b>,</li> <li>• a cable gland fitting; <b>or</b>,</li> <li>• sealant.</li> </ul> <p>The sealing arrangements must be free of signs of gaps or other forms of damage or deterioration.</p> <p>There must be no movement of the pipework within the sealing arrangement when light manual force is applied to the pipework.</p> <p>Where sealant is used it must completely fill the area between the pipe and the adjacent locker structure, and it must not noticeably move or dislodge, and gaps must not open when light manual force is applied to the LPG pipework.</p>	
<p>Applicability – it is acceptable for pipework to exit a locker into a conduit with the gap between the pipework and the conduit sealed with sealant. The conduit must also be sealed to the locker structure.</p> <p>Applicability – the Requirements also apply to electrical cables routed to ignition protected solenoid shut-off valves, where they pass through locker sides below the highest point of the high-pressure stage components.</p>		

<b>7.2.3</b>	<b>Are side-opening cylinder locker doors located where any escaping LPG vapour would flow overboard unimpeded?</b>	<b>R</b>
<p>Check that any side-opening cylinder locker door is located where any escaping LPG vapour would flow overboard unimpeded.</p> <p>If the side-opening locker door is in a cockpit check the arrangements against the specifications for ‘self-draining’ cockpits and ‘open transom’ cockpits in section 1 of Appendix 7.</p>	<p>Side-opening cylinder locker doors must only be openable where any escaping LPG vapour would flow overboard unimpeded.</p> <p>For side-opening locker doors in cockpits to be accepted as being located where any escaping LPG vapour would flow overboard unimpeded the cockpit must comply with the:</p> <ul style="list-style-type: none"> <li>• ‘self-draining’; <b>or</b>,</li> <li>• ‘open transom’ ...</li> </ul> <p>... specifications set out in section 1 of Appendix 7.</p>	
<p>Examiner action – Examiners must refer to section 1 of Appendix 7 for essential information on ‘self-draining’ and ‘open transom’ cockpits.</p> <p>Applicability – where side-opening cylinder locker arrangements are found not to comply with this Requirement, but the vessel is CE marked according to the Recreational Craft Directive or UKCA marked according to the Recreational Craft Regulations, Examiners should contact the BSS Office for guidance.</p>		

7.2.4	Where required, are side-opening locker door seals continuous, in good condition and effective?	R
<p>For side-opening lockers where the door opening is in a cockpit with an 'open-transom' (other than those that are also 'self-draining'), check for the presence of a continuous seal around the door or opening, and check the condition of the seal.</p> <p>For side-opening lockers where the door opening is within 0.5m of any opening into the interior of the vessel, or any source of ignition, check for the presence of a continuous seal around the door or opening, and check the condition of the seal.</p> <p>With the door shut, visually check for signs of gaps between the door seal and the locker body.</p>	<p>Side-opening lockers located in cockpits with 'open transoms' (other than those that are also 'self-draining') must be fitted with a continuous seal around the whole door.</p> <p>Side-opening lockers with door openings within 0.5m of an opening into the interior of the vessel, or any source of ignition, must be fitted with a continuous seal around the whole door.</p> <p>On side-opening doors where seals are required, the seals must be free of signs of:</p> <ul style="list-style-type: none"> <li>• damage or deterioration; <b>and</b>,</li> <li>• gaps with the locker body when the door is closed</li> </ul>	
<p>Examiner action – Examiners must refer to section 1 of Appendix 7 for essential information on 'self-draining' and 'open transom' cockpits.</p> <p>Examiner action – Examiners must refer to section 1 of Appendix 7 for essential information on measuring the minimum separation between side-opening cylinder lockers and openings into the interior of the vessel or sources of ignition.</p> <p>Applicability – sources of ignition include open flame or spark inducing equipment. Solenoid LPG system shut-off valves of suitable proprietary manufacture should be presumed not to be a source of ignition.</p>		

7.2.5	Is the cylinder housing opening(s) in an 'open location', and is the housing ventilated to the outside?	R
<p>Identify any cylinders or cartridges stored in housings.</p> <p>Determine whether the housing opening is in an 'open location' by checking:</p> <ul style="list-style-type: none"> <li>• for any barriers that might prevent escaping LPG vapour flowing overboard unimpeded;</li> <li>• for any openings into the interior of the vessel, or any source of ignition, within 0.5m distance; <b>and</b>,</li> <li>• if the cylinders or cartridges are in a cockpit determine if the cockpit is 'self-draining' as set out in section 1 of Appendix 7.</li> </ul> <p>Where the housing opening is fitted with a door(s), check for the presence of fixed ventilation to the outside when the door(s) is shut.</p>	<p>Cylinder housing openings must be in an 'open location'.</p> <p>To be accepted as being in an 'open location' housing openings must:</p> <ul style="list-style-type: none"> <li>• be in a position where any escaping LPG vapour would flow overboard unimpeded; <b>and</b>,</li> <li>• be where there is no opening into the interior of the vessel, or any source of ignition, within 0.5m distance.</li> </ul> <p>For housing openings to be accepted as being in an 'open location' in a cockpit, the cockpit must comply with the 'self-draining' specifications set out in section 1 of Appendix 7.</p> <p>Housings must be provided with fixed ventilation to the outside when any door(s) are shut.</p>	
<p>Examiner action – Examiners must refer to section 1 of Appendix 7 for essential information on 'self-draining' cockpits.</p> <p>Examiner action – Examiners must refer to section 1 of Appendix 7 for essential information on measuring the minimum separation between cylinder housing openings and openings into the interior of the vessel or sources of ignition.</p> <p>Applicability – where cylinder housing arrangements are found not to comply with this Requirement, but the vessel is CE marked according to the Recreational Craft Directive or UKCA marked according to the Recreational Craft Regulations, Examiners should contact the BSS Office for guidance.</p> <p>Applicability – the nature and precise location of fixed ventilation for housings is not assessed.</p> <p>Supporting information on the difference between lockers and housings is provided at Appendix 7.</p>		



<b>7.2.6</b>	<b>Is the cylinder housing free of any path for escaping LPG vapour to enter the interior of the vessel?</b>	<b>R</b>
<p>Visually check the condition of the internal surfaces and seams of cylinder housings.</p> <p>Visually check the condition of the external surfaces and seams of cylinder housings where they can be seen.</p> <p>Determine which parts of the housing structure if holed or damaged could create a path for escaping LPG vapour to enter the interior of the vessel.</p>		<p>Housing sides, top and bottom must be free of:</p> <ul style="list-style-type: none"> <li>• holes, e.g. caused by drilling, rust or cutting; <b>or</b>,</li> <li>• cracks, splits or de-laminations; <b>or</b>,</li> <li>• missing or damaged welds at seams; <b>or</b>,</li> <li>• other signs of damage or deterioration...</li> </ul> <p>.... that can be determined by visual examination to penetrate the housing to the interior of the vessel.</p>
<p>Examiner action – prior to checking the condition of cylinder housings Examiners must ensure all loose portable items are removed.</p> <p>Examiner action – where a part of the housing is obstructed, e.g. by the cylinders themselves or a mat, then the Check cannot be completed until the obstruction has been removed, moved aside or cleared. Examiners should not disconnect cylinders connected to the LPG system, but where cylinders prevent the condition of the housing being verified the Check cannot be completed until the cylinders have been moved to allow access. Housings not accessible enough to allow an assessment of condition must be recorded as ‘not verified’ on your checklist, and it must be considered that the Check has not been completed until such time as their condition has been verified.</p> <p>Applicability – hatches and any similar temporary openings, however constructed or sealed, that open into the interior of the vessel are not permitted within housings.</p>		

<b>7.2.7</b>	<b>Are the sealing arrangements on LPG pipework exiting the cylinder housing of the correct type to ensure LPG-tightness to the interior of the vessel?</b>	<b>R</b>
<p>Determine whether LPG pipework exiting cylinder housings does so into the interior of the vessel.</p> <p>Where pipework exits cylinder housings into the interior of the vessel, visually check the type and condition of the sealing arrangements.</p> <p>Apply light manual force to the pipework and check for signs of movement at the sealing arrangement.</p>		<p>LPG pipework exiting cylinder housings into the interior of the vessel must exit through either:</p> <ul style="list-style-type: none"> <li>• a bulkhead fitting; <b>or</b>,</li> <li>• a cable gland fitting; <b>or</b>,</li> <li>• sealant.</li> </ul> <p>The sealing arrangements must be free of signs of gaps or other forms of damage and deterioration.</p> <p>There must be no movement of the pipework within the sealing arrangement when light manual force is applied to the pipework.</p> <p>Where sealant is used it must completely fill the area between the pipe and the adjacent housing structure, and it must not noticeably move or dislodge and gaps must not open when light manual force is applied to the LPG pipework.</p>
<p>Applicability – it is acceptable for pipework to exit a housing into a conduit with the gap between the pipework and the conduit sealed with sealant. The conduit must also be sealed to the housing structure.</p> <p>Applicability – the Requirements also apply to electrical cables routed to ignition protected solenoid shut-off valves where they pass through housing structures into the interior of the vessel.</p>		



### 7.3 LPG cylinder locker drains

<b>7.3.1</b>	<b>Is there a drain in the cylinder locker and is the drain outlet above the waterline?</b>	<b>R</b>
<p>Identify the presence of a cylinder locker drain in each cylinder locker.</p> <p>Identify the cylinder locker drain outlet on the outside of the hull and verify that it is above the normal laden waterline.</p>		<p>All cylinder lockers must be fitted with a drain facility.</p> <p>Cylinder locker drain outlets must be on the outside of the hull above the normal laden waterline.</p>
<p>Applicability – on lockers where there is no drain line and the drain outlet is the hole through the locker side, if for any reason canal/river water can enter the cylinder locker through the drain outlet there must always be a higher drain outlet above water level. The area of the drain outlet above water level must be compliant with the drain aperture sizing Requirements at Check 7.3.6.</p> <p>Guidance for owners – on boats where river/canal water can enter a cylinder locker through a locker drain, boat owners are advised to regularly assess the condition of the locker for signs of damage or deterioration. Corrosion on steel lockers can create a path for water to enter the interior of the vessel. Owners are also advised to consider changing such cylinder locker arrangements to prevent river/canal water entering the drain and/or locker.</p> <p>Supporting information on cylinder lockers with openings below the normal laden waterline is provided at Appendix 7.</p>		
<b>7.3.2</b>	<b>Is the drain opening at or close to the bottom of the cylinder locker?</b>	<b>R</b>
<p>Check the location of the cylinder locker drain opening(s).</p>		<p>Cylinder locker drain openings must be located not greater than 30mm above the lowest point of the locker.</p>
<p>Applicability – where drain openings are greater than 30mm above the lowest point of the locker structure it is acceptable for the space below the drain opening to be filled with a suitable material.</p> <p>Supporting information on the proximity of drain openings to the lowest point of cylinder lockers, and on filling space below cylinders, is provided at Appendix 7.</p> <p>Guidance for owners – on boats where the space below the drain opening is filled with a suitable material, boat owners are advised to occasionally remove the material and assess the condition of the locker material for signs of damage or deterioration.</p>		
<b>7.3.3</b>	<b>Is the cylinder locker clear of any items that could block the drain?</b>	<b>R</b>
<p>Check cylinder lockers for any items which could block the drain.</p>		<p>Cylinder lockers must be clear of any item which could block the drain.</p>
<b>7.3.4</b>	<b>Does the drain line fall continuously from the cylinder locker to the drain outlet and are both ends clear of blockage?</b>	<b>R</b>
<p>Check the completeness and fall of the cylinder locker drain line to the drain outlet where it can be seen or reached.</p> <p>Check the drain openings in the cylinder locker and at the drain outlet for obstruction.</p>		<p>Cylinder locker drain lines must be continuous and must fall continuously to the drain outlet in the hull so as not to retain escaping LPG vapour.</p> <p>Drain openings in the cylinder locker and at the drain outlet must not be blocked.</p>
<p>Examiner action – with the consent of the owner, a bucket of water can be used to aid verification of Check Items 7.3.4 to 7.3.6.</p> <p>Supporting information on drain line fall is provided at Appendix 7.</p>		

7.3.5	Is the drain line material, including the connections, in good condition?	R
<p>Check the condition of all cylinder locker drain line material that can be seen or reached.</p> <p>Check the condition of all drain line connections that can be seen or reached.</p> <p>Where connections can be reached, pull using light manual force to check the security of all drain line connections.</p>	<p>The material of drain lines must be free of signs of damage or deterioration.</p> <p>All connections must be complete and free of signs of damage or deterioration.</p> <p>Drain pipe connections must be appropriately tight, that is, not so loose that the connection or pipe moves under light manual force.</p> <p>Drain hoses must be free of any signs of damage or deterioration, including 'soft' spots or kinking of the walls.</p> <p>Drain hose connections made with hose clips or clamps must:</p> <ul style="list-style-type: none"> <li>• be suitably sized, that is, not so oversized that the band forms an elliptical shape or so undersized that no tightness is achieved; <b>and,</b></li> <li>• be appropriately tight, that is, not so loose that the hose can be pulled forward or back under light manual force nor so tight that the hose is excessively pinched; <b>and,</b></li> <li>• show no signs of damage or deterioration at the clip or clamp; <b>and,</b></li> <li>• show no signs of damage or deterioration at the hose.</li> </ul>	

7.3.6	Does the drain facility have a minimum appropriate internal diameter or equivalent area?		R
<p>Measure the internal diameter, or area, of each cylinder locker drain opening.</p> <p>Where it can be seen or reached, check any drain line for no obvious reductions in its diameter.</p>	Cylinder locker drains must have a minimum internal diameter of 12mm (1/2in) or increased pro-rata up to 19mm (3/4in), or have an equivalent area.		
	Total capacity	Minimum internal diameter of drain opening or equivalent area	
	1-18kg	12mm (1/2in)	113mm <sup>2</sup>
	19-29kg	14mm (9/16in)	154mm <sup>2</sup>
	30-37kg	17mm (5/8in)	227mm <sup>2</sup>
38kg or greater	19mm (3/4in)	283mm <sup>2</sup>	
<p>Applicability – total capacity must be calculated from the sum of all cylinders and any cartridges housed in the same drained cylinder locker.</p> <p>Applicability – if two or more drains exist in one locker, their internal diameters or equivalent areas should be added together when checking for compliance.</p>			

## 7.4 Protecting LPG cylinders and components against damage

7.4.1	Are all cylinders secured and stored upright with the valve at the top?	R
<p>Check all cylinders are secured in the upright position with the valve uppermost.</p> <p>Determine by moving the cylinders carefully the extent of any movement.</p> <p>Check that all cylinders are secured to prevent potential damage to regulators or pipework.</p> <p>Check the completeness and condition of support structures and fixings on any transom-mounted cylinder arrangements where they can be seen or reached.</p>	<p>Cylinders, whether full or empty, must be secured in the upright position with the valve uppermost so that:</p> <ul style="list-style-type: none"> <li>the extent of any cylinder movement cannot cause any pulling of pipework or pulling tight of hose; <b>and</b>,</li> <li>the possibility of cylinders damaging low-pressure regulators, pipework or other LPG system components is minimised.</li> </ul> <p>The support structures and fixings on transom-mounted LPG cylinder arrangements must be complete and free of signs of damage or deterioration.</p>	

7.4.2	Is the cylinder locker or housing secured against unintended movement?	R
<p>Apply light manual force to check that cylinder lockers and housings are secured against unintended movement.</p>	<p>Cylinder lockers and housings must be secured against unintended movement under light manual force.</p>	
<p>Applicability – Examiners need not apply light manual force to cylinder lockers or housings that are integral to the boat's hull or superstructure.</p>		

7.4.3	Are cylinders in a locker protected against falling objects?	R
<p>Check for the presence of a lid or cover on all top-opening cylinder lockers.</p> <p>If not present check that the cylinders, regulators and associated equipment are otherwise protected.</p>	<p>Top-opening cylinder lockers must either have:</p> <ul style="list-style-type: none"> <li>a lid or cover; <b>or</b>,</li> <li>cylinders, and other LPG system components within the locker must be otherwise protected against falling objects.</li> </ul>	

7.4.4	Is the cylinder locker or housing clear of any items that could damage the LPG equipment or ignite escaping LPG vapour?	R
<p>Check the contents of all cylinder lockers and housings.</p>	<p>Cylinder lockers and housings must not contain loose sharp or heavy items such as anchors or mooring pins that could damage the cylinders or other LPG system components.</p> <p>Cylinder lockers and housings must not contain any item that could ignite escaping LPG vapour.</p>	
<p>Applicability – sources of ignition include open flame or spark inducing equipment. Solenoid LPG system shut-off valves of suitable proprietary manufacture should be presumed not to be a source of ignition.</p> <p>Guidance for owners – when purchasing solenoid controlled shut-off valves an assurance should be sought from the supplier as to their suitability for use with LPG.</p>		

7.4.5	Is the cylinder locker or housing of suitable proprietary manufacture, and has it been maintained to ensure its integrity is retained?	R
<p>Determine whether the cylinder locker or housing is of suitable proprietary manufacture.</p> <p>Where lockers or housings are not obviously of suitable proprietary manufacture, determine the material type, estimate the thickness, and determine how the seams have been made.</p> <p>Determine the materials used in any repair to cylinder lockers and housings.</p>	<p>Cylinder lockers and housings must be of suitable proprietary manufacture.</p> <p>Cylinder lockers and housings may be accepted as being of suitable proprietary manufacture if they are constructed of materials that are either:</p> <ul style="list-style-type: none"> <li>• the same material and thickness of the surrounding hull structure; <b>or</b>,</li> <li>• metal of minimum thickness of approximately 1mm with fully welded or brazed seams; <b>or</b>,</li> <li>• FRP of minimum thickness of approximately 5mm thickness.</li> </ul> <p>The integrity of cylinder locker and housing seams must not rely upon glue or sealant.</p> <p>To ensure the original integrity is retained, any repairs to cylinder lockers or housings must meet the material thickness Requirements above; <b>and</b>:</p> <ul style="list-style-type: none"> <li>• metal locker or housing repairs must be made using a plate of similar metal and must be seam welded or brazed;</li> <li>• FRP locker or housing repairs must be made using fibreglass fabric/matting and resin.</li> </ul>	
<p>Applicability – lockers and housings of suitable proprietary manufacture made from moulded plastic are considered as replacement items and therefore if damage or deterioration has affected their integrity they should be replaced with new and not repaired.</p> <p>Applicability – it is acceptable for lockers or housings made from the same material as the surrounding hull structure, metal or FRP to be repaired, but it is recognised that it is sometimes difficult to identify the repair method if the repair has been covered in paint. If the method of repair cannot be established but otherwise looks sound, Examiners should pass the arrangements and record notes of their findings on their checklist.</p> <p>Applicability – the above Requirements only apply where a failure of the locker or housing structure could lead to gas escaping from the cylinder or system components within the locker or housing flowing directly into the interior of the vessel, or where the locker or housing structure is within 0.5m of openings into the interior of the vessel or any source of ignition.</p> <p>Applicability – a combination of wooden cylinder lockers lined with FRP of a lesser thickness than 5mm may be estimated as equivalent.</p> <p>Supporting information on lockers and housings of suitable proprietary manufacture is provided at Appendix 7.</p>		

## 7.5 Cylinder locker openings

<b>7.5.1</b>	<b>Is the cylinder locker opening outside of any engine or battery space?</b>	<b>R</b>
Check the location of the cylinder locker opening.	Cylinder lockers must not open into any: <ul style="list-style-type: none"> <li>• engine space; <b>or</b>,</li> <li>• battery space.</li> </ul>	
Examiner action – where a cylinder locker is found to open into an engine space the Examiner should contact the BSS Office for guidance to determine whether there is a known acceptable compliance option available for the model of boat.		

## 7.6 LPG system main shut-off valves

<b>7.6.1</b>	<b>Is the LPG system main shut-off valve, or its means of operation, in a readily accessible position?</b>	<b>R</b>
Identify the LPG system main shut-off valve and check the accessibility of the valve or its means of operation.	The LPG system main shut-off valve, or its means of operation, must be installed in a readily accessible position.	
Applicability – the LPG system main shut-off valve(s) should normally be taken as being the cylinder valve(s).		
Applicability – systems with clip-on regulators do not require an additional system main shut-off valve.		

<b>7.6.2</b>	<b>Is the LPG system main shut-off valve, or its means of operation, in open view, or is the location of the valve or its means of operation clearly marked?</b>	<b>R</b>
Check whether the LPG system main shut-off valve, or the means to operate it, is in open view with all removable lids, deck boards, curtains, doors etc in place.  Where the LPG system main shut-off valve, or the means to operate it, is not in open view, check for the presence of marking in open view indicating the location of the valve or the means to operate it.	The LPG system main shut-off valve, or the means to operate it must: <ul style="list-style-type: none"> <li>• be in open view with all removable lids, deck boards, curtains, doors etc in place; <b>or</b>,</li> <li>• the location of the valve, or its means of operation, must be clearly marked in open view.</li> </ul>	

## 7.7 LPG high-pressure system components

7.7.1	<b>Are all high-pressure LPG system components accessible for inspection and either inside a cylinder locker or in an open location?</b>	<b>R</b>
<p>Check the location and accessibility of all high-pressure LPG system components.</p>	<p>All high-pressure components must be accessible for inspection and located in:</p> <ul style="list-style-type: none"> <li>• a cylinder locker; <b>or</b>,</li> <li>• a cylinder housing; <b>or</b>,</li> <li>• an open location.</li> </ul> <p>To be accepted as being located in an 'open location' high-pressure components must:</p> <ul style="list-style-type: none"> <li>• be in a position where any escaping LPG vapour would flow overboard unimpeded; <b>and</b>,</li> <li>• be where there is no opening into the interior of the vessel, or any source of ignition, within 0.5m distance.</li> </ul> <p>For all high-pressure components to be accepted as being in an 'open location' in a cockpit, the cockpit must comply with the 'self-draining' specifications set out in section 1 of Appendix 7.</p>	
<p>Examiner action – Examiners must refer to section 1 of Appendix 7 for essential information on 'self-draining' cockpits.</p>		

7.7.2	<b>Where two or more cylinders are connected on the high-pressure side, does each connection have a non-return valve fitted?</b>	<b>R</b>
<p>Identify the presence of cylinders connected on the high-pressure side.</p> <p>If present, check for a non-return valve fitted in each high-pressure connection.</p>	<p>Two or more cylinders connected on the high-pressure side must be protected by a non-return valve fitted in each connection.</p>	

7.7.3	<b>Are all hoses on the high-pressure side of pre-assembled lengths not exceeding 1m and to the correct specification?</b>	<b>R</b>
<p>Identify the presence of hose on the high-pressure side.</p> <p>Check the type of hose end fittings.</p> <p>Measure the length of hose.</p> <p>Check the hose markings.</p>	<p>All LPG hoses on the high-pressure side:</p> <ul style="list-style-type: none"> <li>• must consist of pre-made hose assemblies of suitable proprietary manufacture; <b>and</b>,</li> <li>• must not exceed 1m in length; <b>and</b>,</li> <li>• must be marked to BS EN 16436 Class 3; or BS 3212 type 2.</li> </ul>	
<p>Applicability – steel hose assemblies marked to BS EN ISO 10380 can be regarded as equivalent.</p>		

7.7.4	<b>Are all high-pressure LPG system components secure and in good condition?</b>	<b>R</b>
<p>Check the security and condition of all regulators and associated high-pressure equipment and hoses and hose connections by sight and touch. Check fixings for signs of damage or deterioration.</p>		<p>All high-pressure components, including regulators and associated equipment, hoses and hose connections, must be secure and free from signs of damage or deterioration. Hose must be free of leaks, flaws, brittleness, cracking, abrasion, kinking, 'soft' spots, or joins. On hoses covered with metal braiding the braiding must be free of signs of damage or deterioration including corrosion and kinking.</p> <p>Hose connections:</p> <ul style="list-style-type: none"> <li>• must not be made using hose clamps fixed by spring tension; <b>and</b>,</li> <li>• must be free of any missing components, cracks, burrs or rough edges or signs of other damage or deterioration; <b>and</b>,</li> <li>• must not be so narrow as to cut into the hose; <b>and</b></li> <li>• must be suitably sized, that is, not so oversized that the band forms an elliptical shape, or so undersized that inadequate compression is achieved; <b>and</b>,</li> <li>• must be appropriately tight, that is, not so loose that the hose can be pulled forward or back under light manual force nor so tight that the hose is excessively pinched.</li> </ul> <p>Fixings for high-pressure LPG equipment must be free of signs of damage or deterioration.</p>

7.7.5	<b>Are non-cylinder mounted regulators located to prevent damage?</b>	<b>R</b>
<p>Check the location of regulators not mounted directly on cylinders and check whether they are exposed to possible damage when the cylinders are changed or when cylinders are subjected to the extent of any possible movement or rocking whilst in situ.</p> <p>Check that the vent holes of high-pressure stage components are protected from the ingress of debris or water.</p>		<p>Regulators not mounted directly on cylinders must be located in a position where they are not exposed to possible damage when changing cylinders and/or from possible movement of cylinders in situ, or they must be protected from such possible damage.</p> <p>The vent holes of high-pressure stage components must be protected from the ingress of debris or water.</p>

7.7.6	<b>Is the installation free of manually-adjustable regulators?</b>		<b>R</b>
<p>Check for the presence of any manually-adjustable regulators.</p>		<p>LPG regulators must not be of the manually-adjustable type.</p>	
<p>Applicability – manually-adjustable regulators are acceptable for steam boiler or blowlamp engine-start LPG supply systems.</p> <p>Applicability – regulators able to be adjusted upon removal of a 'tools-to-remove' dust cap are acceptable.</p>			



## 7.8 LPG pipework, joints and connections

7.8.1	<b>Are all LPG pipes made of a suitable material, adequately secured and free from damage?</b>	<b>R</b>
<p>Visually check type of material for all LPG pipes that can be seen.</p> <p>Apply light manual force to check the security of LPG pipes that can be reached.</p> <p>Check condition of all LPG pipes that can be seen or reached.</p>		<p>LPG pipes must be made of either seamless copper, stainless steel or copper nickel alloy tube.</p> <p>LPG pipes must not move under light manual force.</p> <p>LPG pipes must be free of kinks, restrictions, abrasion damage or deterioration.</p>
<p>Applicability – Pliable Corrugated Tubing (PCT) to BS EN 15266 and/or BS 7838 can be considered as stainless steel pipework for the purposes of BSS Examinations.</p> <p>Applicability – a little movement at the final connection to an appliance is acceptable but any such unsecured pipe should be kept to a minimum and should generally not be more than 0.5m in length.</p> <p>Applicability – pay particular attention to the potential for abrasion damage on pipes passing through bulkheads.</p>		

7.8.2	<b>Is the LPG pipe protected where it passes through metal bulkheads or decks?</b>	<b>R</b>
<p>Check the protection of LPG pipes passing through metallic bulkheads or decks that can be seen or reached.</p>		<p>LPG pipes passing through metallic bulkheads or decks must be protected by the use of sleeves, grommets, cable glands, bulkhead fittings, or equivalent.</p>
<p>Applicability – it is acceptable for pipe to be protected by sealant provided the sealant is in good condition and that it completely seals the area between the pipe and the surrounding material, and provided the sealant does not noticeably move or dislodge when the pipe is subject to light manual force.</p>		

7.8.3	<b>Are all LPG pipe joints accessible for inspection and of the correct type?</b>	<b>R</b>
<p>Check the accessibility and type of all pipe joints.</p>		<p>All LPG pipe joints must be accessible for inspection.</p> <p>All LPG pipe joints used on copper or copper nickel alloy pipe must be:</p> <ul style="list-style-type: none"> <li>• brass compression joints; <b>or</b>,</li> <li>• brass threaded joints.</li> </ul> <p>All LPG pipe joints used on stainless steel pipe must be:</p> <ul style="list-style-type: none"> <li>• stainless steel compression joints; <b>or</b>,</li> <li>• stainless steel threaded joints; <b>or</b>,</li> <li>• stainless steel welded joints.</li> </ul>
<p>Applicability – joints not accessible for inspection must be recorded as ‘not verified’ on your checklist, and it must be considered that the Check has not been completed until such time as their type has been verified.</p> <p>Applicability – brazed joints are also permitted, but Examiners must take particular care when endeavouring to determine whether such connections are brazed or soft-soldered (which are not permitted). If in doubt Examiners should contact the BSS Office for guidance.</p> <p>Applicability – the material type of some appliance connection joints may not be identifiable. Provided such joints appear to be original to the appliance, Examiners should consider the joint material compliant.</p>		



7.8.4	<b>Are all LPG pipe joints secure, in good condition and competently made?</b>	<b>R</b>
<p>Ensure the distance fixing clips are attached from all joint connections.</p> <p>Apply light manual force to check the security of each joint.</p> <p>Check condition and completeness of fixings and joints.</p> <p>Check all joints for the presence of unnecessary components.</p>		<p>All LPG pipe joints:</p> <ul style="list-style-type: none"> <li>• must have fixing clips attached no more than 150mm from each joint connection and must not move under light manual force; <b>and</b>,</li> <li>• must have fixings that are free of signs of damage or deterioration or missing components; <b>and</b>,</li> <li>• must be free of any signs of missing components, cracks or other signs of damage or deterioration; <b>and</b>,</li> <li>• must be made with a minimum number of individual components.</li> </ul>
<p>Applicability – fixings are required on all sides of joints.</p> <p>Applicability – joints secured by proprietary integral fixings such as mounting plates or bulkhead fittings can be considered as meeting this Requirement. The pipework adjacent to such joints does not need to be provided with additional securing within 150mm of each joint connection.</p> <p>Applicability – joints not accessible for inspection must be recorded as ‘not verified’ on your checklist, and it must be considered that the Check has not been completed until such time as their general condition has been verified.</p> <p>Applicability – the minimum number of components is usually interpreted as two, however, where LPG joints are identified having more than two components, Examiners should contact the BSS Office for guidance.</p>		

7.8.5	<b>Are all pipework spurs that are no longer connected to an appliance properly capped or plugged?</b>	<b>R</b>
<p>Identify any pipework spurs that are no longer connected to an appliance and check they are closed with a ‘tools-to-remove’ proprietary stop-end.</p>		<p>All pipework that is no longer connected to an appliance must be closed with a ‘tools-to-remove’ proprietary stop-end.</p>
<p>Applicability – if a fault is identified take the actions described in Appendix A, and Appendix B if appropriate.</p>		

<b>7.8.6</b>	<b>Are all LPG pipes running through petrol engine spaces jointless and adequately supported?</b>	<b>R</b>
<p>Check for any LPG pipes running through petrol engine spaces.</p> <p>Within such spaces, and where they can be seen or reached, check the pipes for any joints and for the presence of conduit, trunking or other means of support.</p>	<p>LPG pipes running through petrol engine spaces must be:</p> <ul style="list-style-type: none"> <li>• jointless; <b>and</b>,</li> <li>• routed within a conduit or trunking, <b>or</b></li> <li>• supported by fixing clips which are no more than 300mm apart.</li> </ul>	
<p>Applicability – as it is not possible for an Examiner to determine whether a proprietary bulkhead fitting is being used as a pipe joint, or as a sleeve for a continuous pipe, such fittings are exempt from this Requirement.</p> <p>Applicability – for the purposes of this Check, an LPG pipework joint will be deemed to be within the petrol engine space where there is a pathway for LPG to travel from the joint to the petrol engine unimpeded.</p> <p>Guidance for owners – at the time of introducing or amending a gas system, proprietary bulkhead fittings should not be used to join LPG pipes within petrol engine spaces.</p>		

<b>7.8.7</b>	<b>Is the LPG pipe at least 75mm from exhaust system and flue components?</b>	<b>R</b>
<p>Measure the distance that any LPG pipes are from exhaust system and flue components.</p>	<p>LPG pipes must be at least 75mm from exhaust system and flue components.</p>	

## 7.9 Low-pressure LPG hoses and hose connections

<b>7.9.1</b>	<b>Are all low-pressure LPG hoses accessible for inspection, of the correct material and in good condition?</b>	<b>R</b>
<p>Check the accessibility of all low-pressure LPG hoses.</p> <p>Check the markings of all LPG hoses.</p> <p>Check the condition of hoses.</p>	<p>All LPG hoses on the low-pressure side:</p> <ul style="list-style-type: none"> <li>• must be accessible for inspection along their entire length; <b>and</b>,</li> <li>• must be marked to BS EN 16436 Class 2; or BS EN 16436 Class 3; or BS 3212 type 2; <b>and</b>,</li> <li>• must be free of flaws, brittleness, cracking, abrasion, kinking, 'soft' spots or joints.</li> </ul> <p>On hoses covered with metal braiding the braiding must be free of signs of damage or deterioration including corrosion and kinking.</p>	
<p>Applicability – hoses not accessible for inspection along their entire length must be recorded as 'not verified' on your checklist, and it must be considered that the Check has not been completed until such time as their general condition has been verified.</p> <p>Applicability – pre-made hose assemblies conforming to BS 669 or EN 14800 may be used to connect free-standing cookers to LPG supply pipework. BS 669 hoses usually have a red stripe running along the length of the hose but may not be marked with BS 669. EN 14800 hoses should be marked EN 14800. The connections on such hoses must terminate with self-sealing bayonet connections at the connection points to the LPG supply pipework. The portable appliance connection Checks at 7.10 also apply.</p>		

<b>7.9.2</b>	<b>Is all low-pressure LPG hose protected against damage where it passes through bulkheads, decks or partitions?</b>	<b>R</b>
Check the protection for low-pressure LPG hoses passing through bulkheads, decks or partitions.		Low-pressure LPG hose passing through bulkheads, decks or partitions must be protected by the use of sleeves, grommets, cable glands, etc.
<p>Applicability – hose which itself is covered by a proprietary metal braiding does not require additional protection.</p> <p>Applicability – it is acceptable for hose to be protected by sealant provided the sealant is in good condition and that it completely seals the area between the hose and the surrounding material, and provided the sealant does not noticeably move or dislodge when the hose is subject to light manual force.</p>		

<b>7.9.3</b>	<b>Is all low-pressure LPG hose at least 75mm from exhaust system and flue components?</b>	<b>R</b>
Measure the distance that any low-pressure LPG hoses are from exhaust system and flue components.		Low-pressure LPG hoses must be at least 75mm from exhaust system and flue components.

<b>7.9.4</b>	<b>Are all low-pressure LPG hoses used to connect regulators or appliances to LPG supply pipework only, and are they a maximum of 1m in length?</b>	<b>R</b>
<p>Check the location of all LPG low-pressure hoses.</p> <p>Measure the length of any LPG hoses used to connect appliances or regulators to LPG supply pipework.</p>		<p>Except on 'all-hose' systems, low-pressure LPG hoses may only be used to connect a cylinder regulator and/or appliances to the LPG supply pipework.</p> <p>LPG hoses used to connect appliances or regulators to LPG supply pipework must not exceed 1m in length.</p>
<p>Applicability – where a bubble leak detector of suitable proprietary manufacturer is located within a cylinder locker or cylinder housing, up to 1m of hose may be installed between the cylinder mounted regulator and the detector, and up to 1m of hose may be installed between the detector and the supply pipework. The hose between the detector and the supply pipework must be located within the locker or housing.</p> <p>Applicability – where there is a single appliance located very close to the cylinder installation it is permissible for hose to run from the cylinder installation to the appliance without pipework provided the hose length does not exceed 1m.</p> <p>Applicability – for 'all-hose' systems apply Check 7.9.6</p>		

<b>7.9.5</b>	<b>Are all low-pressure LPG hose connections accessible for inspection, of the correct type, secure and in good condition?</b>	<b>R</b>
<p>Check the accessibility of all low-pressure hose connections.</p> <p>Check the type, condition, and completeness of all hose connections.</p> <p>Pull using light manual force to check the security of all hose connections.</p>	<p>All low-pressure LPG hose connections:</p> <ul style="list-style-type: none"> <li>• must be accessible for inspection; <b>and</b>,</li> <li>• must be part of pre-made hose assemblies of suitable proprietary manufacture or use suitable nozzles secured by crimped or worm-drive clamps; <b>and</b>,</li> <li>• must not be made using hose clamps fixed by spring tension; <b>and</b>,</li> <li>• must be free of any missing components, cracks, burrs or rough edges or signs of other damage or deterioration; <b>and</b>,</li> <li>• where made with crimped or worm-drive clamps, the clamps must be suitably sized, that is, not so oversized that the band forms an elliptical shape, or so undersized that inadequate compression is achieved; <b>and</b>,</li> <li>• be appropriately tight, that is, not so loose that the hose can be pulled forward or back under light manual force nor so tight that the hose is excessively pinched.</li> </ul>	
<p>Examiner action – when checking the security of hose connections Examiners must not attempt to twist the hose against the connection.</p> <p>Applicability – hose connections not accessible for inspection must be marked as ‘not verified’ on your checklist, and it must be considered that the Check has not been completed until such time as their condition has been verified.</p>		

<b>7.9.6</b>	<b>Do ‘all-hose’ systems comply with ISO 10239?</b>	<b>R</b>
<p>Check for the presence of an ‘all-hose’ system.</p> <p>If present:</p> <ul style="list-style-type: none"> <li>• Check the routing of all hoses.</li> <li>• Check the type and accessibility of all hose connections.</li> <li>• Check the hose support.</li> <li>• Check for the presence of any LPG pipes.</li> </ul>	<p>In addition to the general hose Requirements at Checks 7.9.1, 7.9.2, 7.9.3 and 7.9.5 ‘all-hose’ hose assemblies must comply with ISO 10239 as follows:</p> <ul style="list-style-type: none"> <li>• each length of hose must be jointless from within the cylinder locker or housing directly to the individual appliance or appliance isolation valve; <b>and</b>,</li> <li>• hoses must have permanently attached end fittings, such as swaged sleeve or sleeve and threaded insert (worm-drive clamps are not permitted); <b>and</b>,</li> <li>• hose connections must be readily accessible; <b>and</b>,</li> <li>• hoses must not be routed through an engine space; <b>and</b>,</li> <li>• hoses must be supported at least at 1m intervals.</li> </ul> <p>On ‘all-hose’ systems there must be no LPG pipes.</p> <p>All hose systems are only permitted where the cylinder(s) is located within a locker or housing.</p>	
<p>Applicability – ‘all-hose’ systems will generally be found on imported boats, CE marked to the Recreational Craft Directive or UKCA marked according to the Recreational Craft Regulations, where the builder has chosen to apply ISO 10239.</p> <p>Applicability – for multi-appliance systems to ISO 10239, anticipate a manifold arrangement within the cylinder locker or housing.</p> <p>Applicability – single cooking appliances connected by hose of no more than 1m in length directly to a regulator are acceptable and need not be assessed against this Check.</p>		

## 7.10 Portable appliance connections

<b>7.10.1</b>	<b>Are all portable appliance connection points provided with an isolation valve?</b>	<b>R</b>
Identify all portable appliance connection points and check for the presence of an isolation valve.		All portable appliance connection points must be fitted with an isolation valve.
<b>7.10.2</b>	<b>Are portable appliance hoses connected with bayonet, plug or screwed fittings, complete and in good condition?</b>	<b>R</b>
Identify the type of appliance hose connection to the isolation valve. Check all connections for completeness and condition.		All hose connections to the isolation valves of portable appliances must be made with a bayonet, plug-in or screwed fitting. All bayonet, plug-in or screwed fittings must not be missing any components and must be free of corrosion, signs of damage or deterioration.
<b>7.10.3</b>	<b>Are all unused screwed portable appliance connection points properly capped or plugged?</b>	<b>R</b>
Identify any unused screwed appliance connection points and determine how they are plugged or capped.		All unused screwed appliance connection points must be closed with a 'tools-to-remove' proprietary plug or cap.

## 7.11 Appliance isolation valves

<b>7.11.1</b>	<b>Can all appliance supply hoses be isolated through individual appliance isolation valves?</b>	<b>R</b>
Identify every appliance connected by hose and confirm the presence of an individual appliance isolation valve at the connection point to the LPG supply pipework.		Appliances connected by hose must be provided with an individual appliance isolation valve at the connection point to the LPG supply pipework.
<p>Applicability – for an installation with a single appliance the cylinder valve(s) may be classed as the appliance isolation valve irrespective of the distance between the appliance and the cylinder(s).</p> <p>Applicability – individual appliance isolation valves in the same LPG pipework spur as the appliance connected by hose, can be considered as meeting this Requirement.</p> <p>Applicability – hob/oven arrangements may be deemed one appliance for the purposes of this Check.</p> <p>Supporting information on the positioning of appliance isolation valves is provided at Appendix 7.</p>		

<b>7.11.2</b>	<b>Are appliance isolation valves of suitable proprietary manufacture?</b>	<b>R</b>
Identify the type of all appliance isolation valves.	Appliance isolation valves must be of suitable proprietary manufacture, and: <ul style="list-style-type: none"> <li>Any tapered-plug type valves used as isolation valves must be spring loaded;</li> <li>Appliance isolation valves at floor level must either be of the drop fan or loose-key type or of a type that cannot be operated inadvertently.</li> </ul>	
<p>Applicability – the Requirements apply to portable appliance connection isolation valves as well as to isolation valves for permanently installed appliances.</p> <p>Applicability – needle-type valves are not considered to be of suitable proprietary manufacture.</p> <p>Applicability – if the spring on a spring-loaded tapered-plug valve is found to be touching the surface behind it, then the valve is not to be considered as being spring-loaded.</p> <p>Supporting information on appliance isolation valves of suitable proprietary manufacture is provided at Appendix 7.</p>		

<b>7.11.3</b>	<b>Are appliance isolation valves, or the means of operating them, readily accessible?</b>	<b>R</b>
Check the accessibility of all isolation valves, or the means of operating them.	Appliance isolation valves, or the means of operating the valves, must be readily accessible.	
<p>Applicability – the Requirements apply to portable appliance connection isolation valves as well as to isolation valves for permanently installed appliances.</p> <p>Applicability – isolation valves located behind free-standing LPG cookers that are restrained from tilting are acceptable provided the restraining method can be unfastened without the use of tools.</p> <p>Guidance for owners – the LPG system main shut-off valve should be considered as the primary emergency shut-off.</p>		

## 7.12 Testing for LPG system tightness

<b>7.12.1</b>	<b>Is there an LPG test point in the system, or a bubble leak detector in the cylinder locker or housing?</b>	<b>R</b>
Check for the presence and location and accessibility of a means to determine the LPG system tightness.	All LPG systems must be fitted with one of the following means to determine gas-tightness: <ul style="list-style-type: none"> <li>a readily accessible proprietary test point fitted in the pipework; <b>or</b>,</li> <li>a readily accessible proprietary test point on an appliance; <b>or</b>,</li> <li>a bubble leak detector installed in a cylinder locker or cylinder housing.</li> </ul>	

<b>7.12.2</b>	<b>Is the LPG system free of leaks as defined in the tightness test?</b>	<b>R</b>
Verify the LPG system is free of leaks by carrying out the appropriate tightness test at Appendix C or Appendix D or D1.	All LPG systems must be free of leaks when tested in accordance with the appropriate tightness test procedure.	
<p>Applicability – if for any reason a tightness test cannot be completed your checklist must be marked as ‘not verified’ and the item considered as non-compliant until such time as verification of tightness is achieved. The reason for non-completion must be recorded.</p> <p>Applicability – if a leak is identified take the actions described in Appendix A. The criteria for a ‘hazardous boat’ notification (Appendix B) to be actioned is set out in Appendix C and D or D1.</p> <p>Examiner action – where, during a tightness test undertaken using a suitable pressure gauge (Appendix C) a regulator is found not to lock-up within industry recommended tolerances, take the actions described in Appendix A, or A and B, and make a note on the BSS Warning Notice about the performance of the regulator. Where it can be established, also note the age of the regulator if it is over 10 years old.</p> <p>Guidance for owners – where, during a tightness test undertaken using a suitable pressure gauge (Appendix C), a regulator is found not to lock-up within industry recommended tolerances owners are guided to have the regulator tested by a Gas Safe registered LPG in boats installer. Replacement regulators should incorporate a means of protecting the downstream pipework and appliances from overpressure in the event of regulator malfunction. It is recommended that regulators over 10 years old should be replaced.</p>		





## BSS Examination Checking Procedures – Part 8

### Appliances and flues

There are five relevant BSS General Requirements:

- 25. All appliances must be designed, installed and maintained in a way that minimises the risks of explosion or of fire starting and spreading.**
- 26. All liquid-fuelled appliances must have an emergency shut-off valve located at a safe distance from the appliance.**
- 27. a) LPG and liquid-fuel burning appliances installed from 3 January 2000.**  
**All burners and pilot lights shall be fitted with a device that automatically shuts off the fuel supply if the burner flame fails.**
- b) LPG and liquid-fuel burning appliances installed before 3 January 2000**  
**Burners on catalytic appliances, appliances with continuously-burning flames and pilot light burners shall be fitted with a device that automatically shuts off the fuel supply if the burner flame fails.**
- 28. All appliance flues must be designed, installed and maintained in a way that minimises the risk of fire.**
- 29. All fuel and power supply systems for appliances must meet these General Requirements where relevant.**

#### 8.1 Appliance fuel and power supply

<b>8.1.1</b>	Check Item 8.1.1 is intentionally not used	<b>R</b>
--------------	--	----------

<b>8.1.2</b>	<b>Are all liquid-fuelled appliances fitted with shut-off valves, and are the valves or their means of operation, in a readily accessible and safe position?</b>	<b>R</b>
--------------	--	----------

Identify all fuel supplies to liquid-fuelled appliances and check for the presence of shut-off valves.  
 Check the position and accessibility of the shut-off valves, or their means of operation.

Liquid-fuelled appliances must be provided with a shut-off valve to shut off the fuel supply.  
 All shut-off valves, or their means of operation, must be installed in a readily accessible position.  
 All shut-off valves, or their means of operation, must be installed within reach of the appliance but not in a position that requires the user to reach over or around the appliance to operate them.

Examiner action – Examiners must refer to Section 1 of Appendix 8 for essential information on examining fuel feed line shut-off valves for liquid-fuelled appliances.

Applicability – the valve should normally be situated in the same compartment as the appliance. However, there may be installations where it is not physically possible or safe to do so. For example: where the appliance is installed on a bulkhead between compartments; or, if there is less than approximately 1m of fuel pipe in the same compartment. In these cases it is acceptable for the valve to be installed at the nearest practicable point.

Applicability – automatic fire valves of suitable proprietary manufacture are an acceptable alternative to manually operated valves. Where fire valves are fitted these may be located immediately adjacent to the appliance.

Applicability – appliances fitted with electrical fuel-supply pumps that shut off the fuel supply when the pump is not in use, are an acceptable alternative to manually operated valves. The control/switch for such pumps does not have to be installed within easy reach of the appliance.

## 8.2 LPG refrigerators on vessels with petrol propulsion engines

8.2.1	<b>Where the vessel has a petrol propulsion engine, is any LPG refrigerator of a proprietary room-sealed type, or a Wilderness Boats conversion of an Electrolux RM 212?</b>	<b>R</b>
<p>If an LPG refrigerator is present on a petrol-engined boat, determine if it is a proprietary room sealed type, or a Wilderness Boats conversion of an Electrolux RM212.</p>	<p>On petrol-engined boats, any LPG refrigerator must be either:</p> <ul style="list-style-type: none"> <li>• a proprietary room sealed type; <b>or</b>,</li> <li>• a Wilderness Boats conversion of an Electrolux RM212.</li> </ul>	
<p>Examiner action – Examiners must refer to section 1 of Appendix 8 for essential information on recognising Wilderness Boats’ converted Electrolux RM212 LPG fridges.</p> <p>Applicability – known room-sealed LPG fridge models include the Electrolux RB180, RB182, RM4213 LSC and RM6401 LSC models.</p> <p>Applicability – this Check is limited to petrol engines, including petrol outboard motors, used as the means of propulsion.</p> <p>Applicability – if the suitability of the fridge cannot be verified from visual assessment and the owner has no declaration from an equipment manufacturer or supplier, mark your checklist ‘not verified’. In such cases, the fridge must be considered as non-compliant until such time as its suitability has been verified.</p> <p>Applicability – in the event a paraffin fridge is found on board a petrol-engined boat Examiners should contact the BSS Office for guidance.</p> <p>Applicability – in the event a fault is determined take the actions described in Appendix A and B.</p>		

8.2.2	<b>On petrol-engined vessels with a Wilderness Boats conversion of an Electrolux RM 212 refrigerator on board, are the burner enclosure and the flame arrestor at the ‘lazy tee’ in place, and is there suitable documentary evidence of recent servicing?</b>	<b>R</b>
<p>On petrol-engined vessels with a Wilderness Boats conversion of an Electrolux RM 212 on board, check for the presence of:</p> <ul style="list-style-type: none"> <li>• a not less than 11 wires per linear cm mesh fitted to the ‘lazy tee’ on the flue pipe; <b>and</b>,</li> <li>• a not less than 11 wires per linear cm mesh enclosure around the burner; <b>and</b>,</li> <li>• documentation confirming that the refrigerator has been serviced by Wilderness Boats or a Gas Safe registered engineer within the previous 12 months.</li> </ul>	<p>On petrol-engined vessels with a Wilderness Boats conversion of an Electrolux RM 212 on board:</p> <ul style="list-style-type: none"> <li>• a not less than 11 wires per linear cm mesh must be fitted to the ‘lazy tee’ on the flue pipe; <b>and</b>,</li> <li>• a not less than 11 wires per linear cm mesh enclosure must be fitted around the burner; <b>and</b>,</li> <li>• there must be documentary evidence that the refrigerator has been serviced by Wilderness Boats or a Gas Safe registered engineer within the previous 12 months of the date of the Examination.</li> </ul>	
<p>Examiner action – Examiners must refer to section 1 of Appendix 8 for essential information on recognising the flame arresting components of Wilderness Boats converted fridges.</p> <p>Applicability – Examiners should take a photograph/retain a copy of the presented documentation to be kept on file with the Examination checklist.</p> <p>Applicability – if the flame arresting mesh on the ‘lazy tee’ and/or the burner enclosure cannot be seen, Examiners should mark their checklist ‘not verified’. In such cases, the fridge must be considered as non-compliant until such time as its suitability has been verified.</p> <p>Applicability – if any part of the flue appears damaged, record a fault at Check 8.10.2 and take the actions described in Appendix A and B.</p> <p>Applicability – in the event a fault is determined at this Check take the actions described in Appendix A and B.</p>		

### 8.3 Installation of appliances in petrol engine spaces

<b>8.3.1</b>	<b>Are petrol-engine spaces free of LPG and/or liquid-fuelled appliances?</b>	<b>R</b>
Check petrol engine spaces for the presence of LPG and/or liquid-fuelled appliances.	LPG and/or liquid-fuelled appliances must not be installed in petrol-engine spaces.	
<p>Applicability – for the purposes of this Check, an LPG and/or liquid-fuelled appliances will be deemed to be within the petrol engine space where there is a direct pathway for LPG to travel from any LPG appliance to the petrol engine or, where there is a direct pathway for any escaped petrol vapour to travel from the petrol engine to the LPG and/or liquid-fuelled appliance.</p> <p>Applicability – in certain circumstances LPG and/or liquid-fuelled appliances may be located in petrol engine spaces where they are installed in a separate vapour-tight compartment. In the event such an installation is identified, or where an owner is claiming compliance or equivalence, Examiners should contact the BSS Office.</p> <p>Applicability – if the appliance is located outside of the engine space, but the air intake to that appliance is located within the space then a fault is to be recorded.</p>		

### 8.4 Protection against fire risks from appliance installations

<b>8.4.1</b>	<b>Are appliances and surrounding surfaces clear of signs of heat damage and leaking fuel?</b>	<b>R</b>
Check all appliances and all their surrounding surfaces for signs of heat damage and leaking fuel, where they can be seen.	<p>Appliances and all their surrounding surfaces must not show signs of:</p> <ul style="list-style-type: none"> <li>• scorching, blistering or discolouration; <b>or</b>,</li> <li>• fuel leakage; <b>or</b>,</li> <li>• heat damage or deterioration to appliance structure.</li> </ul>	
<p>Applicability – this Check applies to all fuel-burning appliances and ‘bullseye’ (also known as ‘domed’) decklights and their surrounding and adjacent surfaces.</p>		

<b>8.4.2</b>	<b>Are all curtains, blinds and other textile materials near to appliances free of heat damage?</b>	<b>R</b>
Check all curtains, blinds and other textile materials near appliances for signs of heat damage, where they can be seen.	Curtains, blinds and other textile materials near all appliances must not show signs of heat damage such as scorching or burning.	
<p>Applicability – this Check applies to curtains, blinds and other textile materials near all fuel-burning appliances and ‘bullseye’ (domed) decklights.</p>		

<b>8.4.3</b>	<b>Are non-portable appliances secured against unintended movement?</b>	<b>R</b>
<p>Check for the presence of securing systems on all non-portable appliances.</p> <p>Where they can be seen or reached, check the condition of the securing systems.</p> <p>Where practicable, apply light manual force to check the security of all non-portable appliances.</p>	<p>Securing systems must be installed on all non-portable appliances, and the securing systems and their fixing points must:</p> <ul style="list-style-type: none"> <li>• be suitable, such as screw/bolt fastenings directly through the appliance's frame (or additional metal brackets) into adjacent boat structure; <b>and</b>,</li> <li>• show no signs of damage or deterioration, including fractured mounting brackets, missing, loose or fractured bolts or nuts.</li> </ul> <p>Non-portable appliances must be secured against unintended movement under light manual force.</p>	
<p>Examiner action – Examiners must refer to section 1 of Appendix 8 for essential information of the securing of solid fuel appliances (including stoves and ranges).</p> <p>Applicability – appliances in gimbals may tilt, but the retaining mechanism must be secure.</p> <p>Applicability – appliances connected to the fuel supply by hoses or electrical cables may be retained using fixed chains provided there is no possibility of strain on the hose and/or cable connections.</p> <p>Applicability – this Check applies to all fuel-burning appliances but does not apply to electrical appliances.</p>		

## 8.5 Protection against fire risks from appliance flues and exhausts

<b>8.5.1</b>	<b>Are all vessel structures, equipment, and curtains, blinds and other textile materials near all appliance flues and exhausts free of signs of heat damage?</b>	<b>R</b>
<p>Check vessel structures, equipment, and curtains, blinds and other textile materials near all appliance flues and exhausts for signs of heat damage, where they can be seen.</p>	<p>Vessel structures, equipment, and curtains, blinds and other textile materials near all appliance flues and exhausts must not show signs of heat damage such as scorching, blistering or discolouration.</p>	
<p>Applicability – this Check applies to all fuel-burning appliances with flues or exhausts.</p>		

## 8.6 LPG catalytic heaters

<b>8.6.1</b>	<b>Are all LPG catalytic heaters compliant with a suitable manufacturing standard?</b>	<b>R</b>
<p>Identify any LPG catalytic heaters and check for the presence of a guard over the heating elements and check the control tap arrangements.</p>	<p>LPG catalytic heating appliances must comply with the elements of:</p> <ul style="list-style-type: none"> <li>• BS 5258-11; <b>or</b>,</li> <li>• BS EN 449</li> </ul> <p>as prescribed below:</p> <p>For compliance with BS 5258-11:</p> <ul style="list-style-type: none"> <li>• the provision of a guard over the heating elements; <b>and</b>,</li> <li>• a three position on-off tap.</li> </ul> <p>For compliance with BS EN 449:</p> <ul style="list-style-type: none"> <li>• the provision of a guard over the heating elements; <b>and</b>,</li> <li>• legible and durable marking of open, closed and any reduced rate positions on control taps; <b>and</b>,</li> <li>• clear marking of any special position of the control tap for ignition.</li> </ul>	

## 8.7 Flame supervision devices

<b>8.7.1</b>	<b>Are flame supervision devices fitted to all LPG and liquid-fuelled appliances that require them?</b>	<b>R</b>
<p>Check all LPG and liquid-fuelled appliances for the presence of flame supervision devices, where the burners or pilot lights can be seen.</p> <p>For any LPG appliance not fitted with flame supervision device(s) seek to determine from the owner, or from available documentary evidence, the date the appliance was installed.</p> <p>For any liquid-fuelled appliance not fitted with flame supervision device(s), seek to determine from the owner, or from available documentary evidence, whether the appliance manufacturer requires such a device to be fitted.</p>		<p>For LPG appliances: All the burners and pilot lights of LPG appliances installed on or after 3 January 2000 must be fitted with a device that automatically shuts off the LPG supply if the burner flame fails. LPG appliances installed before 3 January 2000 must be fitted with a device that automatically shuts off the LPG supply if the burner flame fails on:</p> <ul style="list-style-type: none"> <li>• the burners on catalytic appliances; <b>and</b>,</li> <li>• appliances with continuously-burning flames; <b>and</b>,</li> <li>• pilot light burners.</li> </ul> <p>For liquid-fuelled appliances: Flame supervision devices must be fitted to all liquid-fuelled appliances where the appliance manufacture requires such a device to be fitted.</p>
<p>Applicability – Examiners unsure of whether a particular liquid-fuelled appliance should be fitted with a flame failure device, or seeking clarification as to the suitability of such a device, should contact the BSS Office.</p> <p>Applicability – engine-start blowlamps are not required to have flame supervision devices.</p>		

## 8.8 LPG appliance burner operation

<b>8.8.1</b>	<b>Are all LPG appliance burners delivering a proper flame?</b>	<b>R</b>
<p>Light all LPG appliance burners and operate them at their maximum setting at the same time.</p>		<p>A satisfactory flame picture must be present at each LPG appliance burner when all burners in the system are operating at their maximum setting at the same time.</p>
<p>Examiner action – Examiners must compare flame pictures at each burner to the ‘burner flame trouble chart’ at section 1 of Appendix 8.</p> <p>Examiner action – before operating the burners on any flued appliances, carry out the Checks at 8.10.1/2/3. The flame picture assessment should not be carried out if a fault at 8.10.1/2/3 is recorded.</p> <p>Applicability – any appliances with ‘hidden’ burners must be ignited as part of this Check but there is no Requirement to see the burner flame picture.</p> <p>Applicability – in the event any appliance burner cannot be lit mark your checklist ‘not verified’ and note the reason why. In such cases the burner must be considered as non-compliant until such time as a satisfactory flame picture has been verified.</p> <p>Applicability – in the event of a poor flame picture, take the actions described in Appendix A. In addition, in the event the poor flame picture indicates the flame could extinguish and lead to a gas leak take the actions described in Appendix B.</p>		

## 8.9 Ventilation

8.9.1	Is the vessel provided with adequate fixed ventilation?	A/R
<p>Calculate the fixed ventilation requirements in accordance with Appendix 8a.</p> <p>Measure the total effective area of fixed ventilation.</p> <p>Confirm that the total effective area of fixed ventilation (at least up to the calculated fixed ventilation requirement) is divided as equally as practicable between high and low level.</p>	<p>Fixed ventilation must be in accordance with Appendix 8a.</p>	
<p>Applicability – 8.9.1 is an Advice check for privately owned and managed vessels, but is a mandatory Requirement for hire boats.</p> <p>Applicability – ventilators, doors, windows and hatches that can be closed without the use of tools must not be included in the calculations as these are not considered fixed ventilation.</p> <p>Applicability – permanent and measurable gaps around doors and windows when the windows or doors are fully closed can be taken into account as part of the fixed ventilation provision.</p> <p>Applicability – in the event significant shortfalls in fixed ventilation are determined take the actions described in Appendix A. A significant shortfall is:</p> <ul style="list-style-type: none"> <li>• where the total effective area of fixed ventilation is 50%, or less, of the calculated fixed ventilation requirement; <b>or</b>,</li> <li>• where the total effective area of fixed ventilation is less than the calculated fixed ventilation requirement for appliances with continuous-burning flames; <b>or</b>,</li> <li>• where there is no high or no low-level fixed ventilation.</li> </ul> <p>Guidance for owners – on privately owned boats which have closable ventilators because they proceed to sea, owners are recommended to affix warning notices on or near all non-room-sealed fuel-burning appliances. The warning notice should read: ‘WARNING – Open ventilator(s) before use’, or equivalent.</p>		

8.10.1	Are all appliances requiring a flue or exhaust fitted with one?	A/R
<p>Where they can be seen or reached, check the flueing or exhaust arrangements on all appliances designed exclusively for use with a flue or exhaust.</p>	<p>A flue or exhaust must be fitted to all appliances designed exclusively for use with one. In particular:</p> <ul style="list-style-type: none"> <li>• a flue and draught diverter must be fitted to all multi-point instantaneous water heaters and those single point instantaneous water heaters supplying a shower or bath; <b>and</b>,</li> <li>• a flue or exhaust must be fitted to any appliance fitted with a flue or exhaust spigot and any solid fuel or oil burning appliance; <b>and</b>,</li> <li>• flue components including air intake and flue ductwork and terminals must be fitted to all room-sealed appliances; <b>and</b>,</li> <li>• flues must not serve more than one appliance.</li> </ul>	
<p>Applicability – 8.10.1 is an Advice check for privately owned and managed vessels, but is a mandatory Requirement for hire boats.</p> <p>Applicability – in the event a fault is determined take the actions described in Appendix A.</p>		

8.10.2	Are all appliance flues and exhausts complete and in good condition?	A/R
<p>Check the condition of all appliance flues and exhausts, including ductwork, flue/exhaust terminals and flue/exhaust joints and securing mechanisms that can be seen or reached.</p>	<p>All appliance flues and exhausts must be complete, properly fitted and maintained and must show no obvious signs of:</p> <ul style="list-style-type: none"> <li>• obstruction or flue diameter restriction; <b>or</b>,</li> <li>• crushed or blocked terminals; <b>or</b>,</li> <li>• modifications to the flue/exhaust not in accordance with the appliance manufacturer's recommendations; <b>or</b>,</li> <li>• damage or deterioration; <b>or</b>,</li> <li>• evidence of flue/exhaust gases escaping into cabin areas (soot deposits etc).</li> </ul>	
<p>Applicability – 8.10.2 is an Advice check for privately owned and managed vessels, but is a mandatory Requirement for hire boats.</p> <p>Applicability – LPG fridges in non-petrol-engined boats may be installed without comment, to open-vent into the boat's interior providing no flue components are added to the appliance's integral flue stack.</p> <p>Applicability – instantaneous water heater flue length and terminal suitability will be determined by the flue spillage test at Check 8.10.4.</p> <p>Applicability – in the event a fault is determined take the actions described in Appendix A.</p> <p>Guidance for owners – Examiners only check the condition of flues and exhausts where they can be seen or reached. As deterioration often develops hidden from view, owners are recommended to have flues and exhausts checked annually, or as recommended by the appliance manufacturer, by a competent person.</p>		

## 8.10 Appliance flues and exhausts

8.10.3	Do all appliance flues and exhausts terminate directly to outside air?	A/R
<p>Check the location of all flue and exhaust terminals.</p> <p>Check for the presence of a canopy or canopy fixings where a flue/exhaust terminates at any part of the vessel which could be enclosed by a canopy.</p>	<p>Appliance flue and exhaust terminals must be located outside the interior of the vessel and outside of any areas which may be enclosed by a canopy.</p>	
<p>Applicability – 8.10.3 is an Advice check for privately owned and managed vessels, but is a mandatory Requirement for hire boats.</p> <p>Applicability – in the event a fault is determined take the actions described in Appendix A.</p>		



8.10.4 Are all open flues to LPG appliances operating effectively?	A/R
Carry out a flue spillage test on all open flues connected to LPG appliances as described in Appendix E.	Open flues to LPG appliances must ensure safe transfer of flue gases to the outside of the boat.
<p>Applicability – 8.10.4 is an Advice check for privately owned and managed vessels, but is a mandatory Requirement for hire boats.</p> <p>Examiner action – before operating the burners on any open-flued appliances such as instantaneous water heaters carry out the Checks at 8.10.1, 8.10.2 and 8.10.3. The flue spillage test should not be carried out if:</p> <ul style="list-style-type: none"> <li>• a fault at 8.10.2/3 is recorded; <b>or</b>,</li> <li>• there is no flue pipe connected to the draught diverter; <b>or</b></li> <li>• a Tannoy vent, or similar, is in use as the flue terminal.</li> </ul> <p>Supporting information is provided at Appendix 8.</p> <p>Applicability – if for any reason the flue spillage test cannot be carried out mark your checklist ‘not verified’ and note the reason why.</p> <p>Applicability – Examiners are not required to undertake a flue spillage test on fridges with open-flues.</p> <p>Applicability – in the event a fault is determined, take the actions described in Appendix A.</p>	

8.10.5 Are all solid fuel appliances free of unintended gaps?	A/R
Check the condition of solid fuel appliance surfaces, seams and openings which can be seen.	Solid fuel appliances must show no obvious signs of: <ul style="list-style-type: none"> <li>• unintended gaps or cracks in the outside surface or seams of the stove; <b>or</b>,</li> <li>• unintended gaps greater than 2mm in the loading door seal or door glass; <b>or</b>,</li> <li>• loose, damaged or missing cover plates.</li> </ul>
<p>Applicability – 8.10.5 is an Advice check for privately owned and managed vessels, but is a mandatory Requirement for hire boats.</p> <p>Applicability – some designs of solid fuel appliance have deliberate gaps, commonly above or around the door (to allow air in and help keep the window clean) or below the fuel bed (often by way of a deliberately loose air control) to help keep the fire alight, but where it is clear that components were designed to seal to each other, the above Requirement applies.</p> <p>Applicability – in the event a fault is determined take the actions described in Appendix A.</p>	



**BSS Examination Checking Procedures – Part 9**

**Pollution prevention**

There are two relevant BSS General Requirements:

- 30. Any leakage of oil from engine equipment must be contained and prevented from being avoidably discharged overboard.**
- 31. Bilge pumping and toilet systems must be designed, installed and maintained in a way that minimises the risk of avoidable pollution.**

**9.1 Engine/gearbox oil leak collection**

<b>9.1.1</b>	<b>Will all oil leaks from the engine/s or gearbox/es be collected in an engine tray or oil-tight area?</b>	<b>R</b>
<p>Check for the presence and condition of an engine tray or oil-tight area under all fixed internal combustion engines and gearboxes.</p> <p>Check the type and condition of the materials that make up the engine tray or oil-tight area where they can be seen.</p> <p>Estimate the volume of any engine tray and the capacity of the protected engine and gearbox.</p>	<p>All fixed internal combustion engine and gearbox installations must have an engine tray or oil-tight area.</p> <p>Each engine tray or oil-tight area must be at least as long and as wide as the combined length/width of the engine and gearbox.</p> <p>The material of each engine tray or oil-tight area must be non-porous and oil resistant.</p> <p>All engine trays or oil-tight areas, including joints and seams, must be free of signs of leaks, damage and deterioration.</p> <p>The volume of each engine tray or oil-tight area must be sufficient to retain the estimated capacity of the engine/gearbox sumps.</p>	
<p>Applicability – oil-tight areas must collect from within the engine space and must not extend into other parts of the vessel.</p>		

<b>9.1.2</b>	<b>Where a fixed bilge pump or fixed bilge suction line draws from an engine tray or oil-tight area is the risk of pollution minimised?</b>	<b>R</b>
<p>Check for presence of a fixed bilge pump or fixed bilge suction line within an engine tray or oil-tight area.</p> <p>If present, check for the presence of a bilge water filter installed in the overboard discharge line or the facility to discharge to a holding tank.</p> <p>If a bilge water filter is present, verify the discharge level performance by examining any markings on the filter, or if necessary, any presented declaration from the manufacturer or supplier.</p>		<p>Fixed bilge pumps and fixed bilge suction lines must not draw from an engine tray or oil-tight area, unless the:</p> <ul style="list-style-type: none"> <li>• discharge is through a bilge water filter capable of a 5ppm discharge performance level, as verified by markings on the filter or an appropriate declaration from the manufacturer or supplier; <b>or</b>,</li> <li>• there is a facility to discharge to a holding tank.</li> </ul>
<p>Examiner action – if a portable bilge pump or bilge suction line is discovered within an engine tray or oil-tight area, the owner should be advised to remove it, but no fault recorded.</p> <p>Applicability – for the following makes of bilge water filter a 5ppm discharge performance level can be assumed – Wavestream and Bilgeaway. For all other makes, in cases where the discharge performance level of a bilge water filter cannot be verified, ‘not verified’ must be marked on your checklist, and the filter must be considered as non-compliant until such time as the performance level is verified.</p> <p>Applicability – if a significant quantity of fuel or oil is found to be escaping into the watercourse during an Examination, take the actions described in Appendix A and B.</p> <p>Guidance for owners – the effectiveness of bilge water filters is entirely dependent on the element/cartridge being unclogged. To help ensure contaminated bilge water is not pumped into the watercourse, boat owners must ensure the element/cartridge is replaced as required.</p> <p>Supporting information on recognising 5ppm bilge water filters is provided at Appendix 9.</p>		

## 9.2 Sanitation systems

<b>9.2.1</b>	<b>Is a closable valve fitted in the discharge line of any toilet or toilet holding tank with overboard discharge?</b>	<b>R</b>
<p>Check all toilets and toilet holding tanks for the presence of an overboard discharge line.</p> <p>If present, check for the presence of a closable valve installed in the discharge line and check its condition and completeness.</p>		<p>All toilets and toilet holding tanks having an overboard discharge line must have a closable valve fitted in the discharge line.</p> <p>The valve and connections must be complete and leak-free.</p>
<p>Examiner action – Examiners must not operate sanitation system valves.</p> <p>Applicability – depending on the system’s actual configuration, on installations with a direct overboard discharge and a holding tank the diverter valve may function as the closable valve.</p> <p>Applicability – if toilet waste is found to be escaping into the watercourse during an Examination contact the BSS Office and take the relevant actions described in Appendix B.</p> <p>Supporting information on toilet and holding tank configurations with overboard discharge is provided at Appendix 9.</p>		

# Intentionally Blank

<b>A</b>	<b>People Or Property In ‘Immediate Danger’ Or ‘At Risk’</b>
<b>B</b>	<b>‘Immediately Hazardous Boats’</b>
<b>C</b>	<b>LPG Installations Tightness Testing Using a Manometer (‘U’-Gauge)</b>
<b>D</b>	<b>LPG Installations Tightness Testing Using a Post 2008 Alde 4071 Bubble Tester</b>
<b>D1</b>	<b>LPG Installations Tightness Testing Using a Pre-2008 Alde 4071 Leak Detector, or Other Makes of Bubble Tester</b>
<b>E</b>	<b>Flue Spillage Test – Open-Flued Appliances</b>
<b>F</b>	<b>230V AC Safe Disconnection Process</b>
<b>G</b>	<b>Disabled, Decommissioned Or Disconnected Systems</b>
<b>2</b>	<b>Part 2 – Permanently Installed Fuel Systems and Fixed Engines</b>
<b>2a</b>	<b>2a – Requirements for Diesel Leak-Off Arrangements</b>
<b>2b</b>	<b>2b – Requirements for Steam Engine Pressure System Inspection Certificates</b>
<b>3</b>	<b>Part 3 – Electrical Systems</b>
<b>4</b>	<b>Part 4 – Electrical Propulsion Systems</b>
<b>5</b>	<b>Part 5 – Outboard &amp; Portable Combustion Engines, Portable Fuel Systems &amp; Spare Fuel</b>
<b>6</b>	<b>Part 6 – Fire Extinguishing, Escape and Carbon Monoxide Alarms</b>
<b>7</b>	<b>Part 7 – Liquefied Petroleum Gas (LPG) Systems</b>
<b>8</b>	<b>Part 8 – Appliances and Flues</b>
<b>8a</b>	<b>8a – Requirements for Fixed Ventilation</b>
<b>9</b>	<b>Part 9 – Pollution Prevention</b>



### **The BSS Warning Notice**

**Complete a BSS Warning Notice in all cases where you suspect that people or property may be, or are, in ‘immediate danger’ or ‘at risk’ from faults in installations or appliances on a vessel being examined.**

Several BSS Checks contain Applicabilities specifying where the actions described in Appendix A (or Appendix A and B) are to be taken.

The LPG tightness test Appendices require that if an LPG leak is identified you must take the actions described in Appendix A. The gas leak criteria for a ‘Hazardous Boat Notification’ (Appendix B) to be actioned are also set out in Appendix C and D or D1.

The purpose of the BSS Warning Notice is to alert: -

- the owner or person responsible for the craft’s condition that an immediately hazardous defect has been found; **and**,
- anyone stepping aboard that they could be at risk and should take precautions.

### **Notes for completing a BSS Warning Notice**

Hazardous Boat Notification: Mark the box with a cross if applying Appendix B.

Defect class tick boxes: All defects that are not LPG, ventilation or AC electrical system related, e.g. leaking fuel, please tick next to ‘other (see description)’ and write a brief description of the hazard in the space provided; for example, imminent risk of fuel-hose failure or significant quantities of fuel or other substances escaping into the watercourse.

Boat name: Insert the boat name.

Brief description of boat: Note the size. If you know the model and maker state these, if not, type and material e.g. 23ft FRP cruiser.

Index/registration/WIN: Record at least one of these unique identifying marks whenever possible. (WIN is the Watercraft Identification Number, previously HIN or CIN, a 14-digit code issued to new build boats).

Description of the defect: Insert the BSS Check Item number, but if not applicable write N/A. Always insert a brief description of the potential hazard. e.g. gas leak, flue gas spillage, heat damaged cables, electrical fire risks, poor ventilation, petrol leak, potential electric shock, etc.

LPG supply disconnected: If Appendix B is applied because an immediate danger due to an LPG installation or appliance fault requires the disconnection of the LPG supply, put a Y or N in the box.

Owner aware of defect: The owner (or representative) must be informed of the hazards concerned and advised to seek competent help to rectify the defect. Put a Y or N in the box. If the owner is not informed, add the reason why. If the owner has been informed, but does not commit to fix the defect, contact the BSS Office.

Date/time notice issued: Insert the date and precise time (24-hour clock) of the issue of the BSS Warning Notice.

Signed: Sign in the box and add your BSS PIN.

Hand the two top copies of the BSS Warning Notice to the owner, or send one copy (printed version or electronic means) if not present. Advise the owner to leave one copy displayed in a prominent position on board the boat (or leave one copy yourself if owner not present). The position should be where anyone entering onto the boat will be sure to see it. Retain the yellow copy with the boat’s Examination records.

## **EXAMINER ISSUE OF PUBLISHED SAFETY RELATED GUIDANCE**

If the defects relate to leaking flue gases from appliances, or a significant shortfall in the fixed ventilation provision, the Examiner is to include with the BSS Warning Notice a copy of the BSS leaflet entitled 'Carbon Monoxide Safety on Boats'. In the event no leaflet is left for any reason the Examiner must arrange for one to be sent to the owner by the BSS Office.

**Note:** BSS Examiner Conditions of Registration require that Examination records be kept for at least six years as these could be important in any future investigations or legal proceedings.

### **Hazardous Boat Notifications - definition**

Hazardous Boat Notifications apply where you suspect that people or property may be, or are, in ‘immediate danger’ and consist of a combination of notifications applied as appropriate as described below, to the owner, relevant third parties and/or the BSS Office.

### **Hazardous Boat Notification Actions**

A BSS Warning Notice must be completed in accordance with Appendix A in all cases where you apply Appendix B.

Where the hazard(s) placing people or property in ‘immediate danger’ relate to:

- leaking gas, where the extent of the LPG leak meets the criteria for a Hazardous Boat Notification to be actioned, as set out in Appendix C and D or D1;
- leaking petrol;
- gas refrigerators with naked flames on petrol-powered boats;
- severely heat damaged cables or other significant or immediate electrical fire risks;
- AC electrocution risks;
- escaping appliance flue gases into the interior of the vessel in circumstances where the hazard cannot be controlled by disconnecting the fuel supply to the system or appliance;
- significant quantities of fuel or other substances escaping into the watercourse.

...take the following Hazardous Boat Notification actions in addition to those actions in Appendix A:

- inform the owner (or representative) about the hazards as soon as possible;
- ask for the hazard to be made safe or controlled immediately, such as by turning off the fuel or disconnecting the electricity supply;
- recommend that the systems, installations or appliances are not used again until fixed;
- recommend that any repairs are carried out by a competent person.

It is recommended that a brief note is made and kept with your personal record concerning any action taken by the owner (or representative) to control the hazard or any proposed actions.

### **Further necessary notifications**

Further notifications will be necessary in circumstances:

- Where the owner (or representative) refuses to co-operate in making safe or controlling the hazard, then urgently notify the BSS Office;
- Where the boat is located at any mooring, marina, or basin operated by a third party, notify a person representing the organisation responsible for those moorings of the situation, and the action taken;
- Where the hazard cannot be made safe or controlled **and** the person representing the organisation responsible for the boat mooring could not be contacted, then urgently notify the BSS Office;
- Where the hazard cannot be made safe or controlled **and** neither the person representing the organisation responsible for moorings or the BSS Office could be contacted, then urgently notify the relevant navigation authority or harbour authority, if necessary, by using emergency contact telephone numbers;
- Where an emergency situation exists and contact with the emergency services, as necessary.



## **Hazards requiring the gas supply to the installation or appliance to be turned off**

Take the additional actions detailed below if the hazards relate to:

- leaking gas, where the extent of the LPG leak meets the criteria for a 'hazardous boat' notification to be actioned as set out in Appendix C and D or D1; **or**,
- leaking flue gases from LPG appliances, in any unusual circumstance where the hazard cannot be controlled by disconnecting the LPG supply to the system or appliance

Additional actions:

- Explain to the owner the immediate danger and why the gas supply to the installation or appliance should be immediately turned off;
- Inform the owner that the installation or appliance should not be used until a competent person rectifies the fault(s);
- Request the owner to turn off or disconnect the gas supply at cylinder(s), main shut-off valve(s), or the appliance as appropriate and, if appropriate, replace any protective caps or plugs to the disconnected cylinder connections;
- Secure an LPG Warning Label in a prominent position on or near the main shut off valve or appliance as appropriate.

Important note. You must take special care if the action taken results in the disconnection of the heating systems on boats with people living on board in cold weather.

In extreme cases e.g., where there are elderly, young or disabled people on board, it may be necessary to recommend to the owner to notify Social Services, or other authorities, or friends or family so that alternative sources of heat can be provided.

## **Making and Reporting Hazardous Boat Notifications**

In circumstances where the hazard(s) placing people or property in 'immediate danger' cannot be made safe or controlled, urgent notifications should be made face-to-face if relevant, or by phone.

Other notifications can be made by other means including email.

All Hazardous Boat Notifications must be reported to the BSS Office. This is achieved when you complete the 'HB Note' section of the boat record on the BSS Examination database. At the time the information is entered an automated email is then sent to BSS Office team members.

### **Smell Of Gas On Board**

If upon entering a boat or at any time during a BSS examination an Examiner smells gas, and where they have cause to suspect that people or property may be or are in 'immediate danger' or 'at risk' due to leaking gas, they must take the actions described in ECP Appendix A (BSS Warning Notice) and Appendix B (BSS Hazardous Boat).

If gas is smelt during a tightness test and where the Examiner has cause to suspect that people or property may be or are in 'immediate danger' or 'at risk' due to leaking gas they should also terminate the tightness test and record a non-compliance at Check 7.12.2.

### **Boats Within Scope Of The Gas Safety (Installation & Use) Regulations (GSIUR)**

Hire boats, passenger boats, residential boats, houseboats and floating businesses fall within the scope of the Gas Safety (Installation and Use) Regulations (GSIUR). For any 'work' undertaken on these classes of vessel it is obligatory that the person undertaking the 'work' is licenced for that activity with Gas Safe Register. The definition of 'work' within the Regulations includes the removal and replacing of a screwed test nipple on a gas-tightness test point.

Non-Gas Safe registered BSS Examiners can only complete Check 7.12.2 on boats within the scope of the Regulations by either:

- undertaking a tightness test using a bubble leak tester as prescribed at Appendix D; or
- observing and recording the pressure gauge tightness test conducted by a Gas Safe Register Licenced gas operative (LPG-boats competency showing on licence card).

Additional information is available on the BSS website - search 'Boats in scope of GSIUR'

### **Suitable Pressure Gauges**

This procedure may only be undertaken using a suitable proprietary fluid 'U' gauge or electronic gauge. Fluid 'U' gauges shall be capable of being read to 0.5 mbar, and electronic gauges shall be capable of being read to 0.1 mbar.

### **Definition Of 'No Discernible' Movement**

A movement of 0.25 mbar or less on a fluid 'U' gauge is considered to be 'not discernible'. Therefore, if the gauge is seen to move, it can be inferred that the pressure within the installation has altered by more than 0.25 mbar.

It follows that, where a gauge that can register discernible movement of less than 0.25 mbar, i.e. an electronic gauge is used, the pass criteria of 'no discernible' movement has to be considered to be a maximum of 0.25 mbar except for those gauges that read to one decimal place when 'no discernible' movement is considered a maximum of 0.2 mbar.

### **Maximum LPG Installation Pipework Volumes**

This procedure can only be used for installations with a pipework volume less than 0.002m<sup>3</sup> for propane and 0.0015m<sup>3</sup> for butane. On most small craft the pipework volumes will be less than these maximum volume parameters, but on vessels where there is an exceptionally large quantity of pipework, and/or pipework with particularly large diameters (e.g. 15mm and above), Examiners should be cautious and calculate the pipework volume. If the pipework volume exceeds 0.002m<sup>3</sup> for propane or 0.0015m<sup>3</sup> for butane contact the BSS Office for advice.

Table C.1 provides the volume for a 1m length of the pipework diameters indicated. Examiners may determine the installation volume by estimating the length of each diameter of pipe installed on the boat in metres, and multiplying it by the appropriate volume given in the table. The total volume in m<sup>3</sup> is then determined by adding the volumes of each diameter of pipe together.

Examiners are also required to calculate the pipework volume for all boats where the LPG installation is found not to be gas-tight. As set out at Step C.6 (and in Table C.3), in the event of a gas leak Examiners must know the pipework volume when determining whether or not to follow the Hazardous Boat Procedures.

**Table C.1 Example Pipe Volumes**

Copper Tube Size (inches/mm)		Volume for 1m length (m <sup>3</sup> )
1/4"	6mm	0.00002
5/16"	8mm	0.00004
3/8"	–	0.00005
–	10mm	0.00006
1/2"	–	0.00010
–	15mm	0.00014
–	22mm	0.00032

### The BSS Requirements and BSS Examination Checking Procedures Appendices A and B

For a 'pass' at Check 7.12.2, there must be no discernible pressure drop during the tightness test (Step C.3.) and no let-by (Step C.4.).

If there is a discernible pressure drop at step C.3 or let-by is present Examiners must follow the procedures in Appendix A (issue a BSS Warning Notice).

The procedures at Appendix B (BSS Hazardous Boat) are only applied in circumstances where the pressure drop during the tightness test at C.3. exceed the relevant figures in Table C.3.

Therefore, in summary, a BSS Warning Notice must be issued for any discernible pressure drop (or if let-by is present), but the BSS Hazardous Boat Procedures are only activated in cases where the pressure drop exceeds the relevant figures in Table C.3.

### Guidance on the Test Procedures

The following procedures assume the installation is connected to one or more LPG cylinders. Do not proceed with the test if the boat's gas supply is shore-based (contact the BSS Office for advice).

Only proceed with the test once the Checks at 7.1.1 to 7.12.1 have been applied. Do not proceed with the test if:

- faults have been identified which could compromise the gas tightness of the installation; or
- a non-compliance has been identified at Check 7.8.3; or
- there is a smell of gas on board and the Examiner has cause to suspect that people or property may be or are in 'immediate danger' or 'at risk' due to leaking gas.

For installations where there is an in-line shut-off valve immediately downstream of the regulator this should be taken as the 'supply control valve'. For installations where there is no in-line shut-off valve immediately downstream of the regulator the cylinder valve(s) should be taken as the 'supply control valve'.

### C.1 Preparations

1. Ensure all burner control taps, including any for pilot burner supplies, are turned off;
2. Ensure any appliance isolation valves and any additional in-line shut-off valves are open (on a cooker with a fold down lid, lift the lid to the fully open position to ensure activation of any safety shut-off valves);

**Table C.2 Industry Recommended Regulator Lock-Up Criteria**

Gas Type	Nominal Operating Pressure	Maximum stable Lock Up Pressure	Maximum time to stable lock-up Pressure
Butane	28 mbar	40 mbar	60 sec
Propane	37 mbar	50 mbar	60 sec
LPG <sup>L</sup>	30 mbar	40 mbar	60 sec

**C.6 Hazardous Boat Activation**

1. If the pressure drop recorded during the tightness test procedure at step C.3.3 exceeds the relevant figure in Table C.3 the Hazardous Boat Procedures at Appendix B must be followed. If the recorded pressure drop does not exceed the relevant figure in Table C.3 no further action is required other than to follow the procedures at Appendix A.

Note 11 – utilise the criteria for Propane, for 30 mbar caravan regulators using butane or propane, or a mix.

**Table C.3 Hazardous Boat Activation Criteria**

Gas Type	Installation Volume (m <sup>3</sup> )	Pressure Drop (in 2 Minutes) Criteria for Hazardous Boat activation (mbar)
Butane (Tightness test pressure 20 mbar)	≤ 0.001	> 3.0
	> 0.001 ≤ 0.0015	> 2.0
Propane (Tightness test pressure 30 mbar)	≤ 0.001	> 4.0
	> 0.001 ≤ 0.002	> 2.0

## **D** Appendix – LPG installations tightness testing using a post 2008 Alde 4071 bubble leak detector

---

### **Smell of Gas on Board**

If upon entering a boat or at any time during a BSS Examination an Examiner smells gas, and where they have cause to suspect that people or property may be or are in 'immediate danger' or 'at risk' due to leaking gas, they must take the actions described in ECP Appendix A (BSS Warning Notice) and Appendix B (BSS Hazardous Boat).

If gas is smelt during a tightness test and where the Examiner has cause to suspect that people or property may be or are in 'immediate danger' or 'at risk' due to leaking gas they should also terminate the tightness test and record a non-compliance at Check 7.12.2.

### **Guidance on the Alde 4071 Leak Detector Test Procedure**

The following procedure assumes that the installation is connected to one or more LPG cylinders. Do not proceed with the test if the boat's gas supply is shore-based (contact the BSS Office for advice).

Only proceed with the test once the Checks at 7.1.1 to 7.12.1 have been applied. Do not proceed with the test if:

- faults have been identified which could compromise the gas tightness of the installation; or
- a non-compliance has been identified at Check 7.8.3; or
- there is a smell of gas on board and the Examiner has cause to suspect that people or property may be or are in 'immediate danger' or 'at risk' due to leaking gas.

Only use a bubble leak tester to determine the tightness of an LPG installation if it is:

- a) a permanently installed ALDE Leak Detector model 4071;
- b) installed in a cylinder locker or housing;
- c) in a readily accessible location which enables:
  - the test button to be clamped down for an uninterrupted 2 minute period; and,
  - a clear view of the fluid chamber to be safely maintained for an uninterrupted 2 minute period;
- d) installed level, and securely mounted using the manufacturer's proprietary fixing points;
- e) installed so that the direction of flow of gas is correct;
- f) installed immediately after the regulator.

The test procedures assume the ALDE's test button can be held down using a clamp, but where this is not practicable Examiners may depress and hold down the test button by hand at steps D.2.2. and D.3.1.

Also, do not proceed with the test if:

- g) the fluid in the chamber appears opaque or coloured (which indicates it is contaminated);
- h) the top of the fluid in the chamber is visibly above or below the area between the two-level indicator lines around the circumference of the chamber;
- i) on a butane system the ambient temperature is below 10°C.

This procedure is for post 2008 ALDE 4071 models only. This is because the manufacturer's production quality since that date provides full confidence concerning the results from applying the test procedure.

In the event the bubble tester is not recognised as a post-2008 ALDE 4071 Leak Detector, utilise Appendix D1.



**Figure 1.** A post-2008 ALDE Leak Detector.

The current model 4071 is available with a blue or a silver finish to the main body.



**Figure 2.** '4071'

should be clearly visible on a label on the red test button.



**Figure 3.** A pre-2008 ALDE model.

Appendix D1 applies.



If an ALDE 4071 Leak Detector is fitted, but is found to be obviously damaged, or does not meet all the installation requirements at items b) to i), above, the Detector cannot be used to undertake a tightness test.

## The BSS Requirements and Appendices A and B

For a 'pass' at Check 7.12.2, there must be 3 or less bubbles over the 2-minute test period for butane, or 4 or less bubbles for propane (see Table D.1.).

If 4 or more bubbles are seen on a butane system, or 5 or more on a propane system, a 'fail' must be recorded at 7.12.2 and Examiners must follow the procedures in Appendix A.

The procedures at Appendix B (BSS Hazardous Boat Notification) are only applied in circumstances where the leak rate is such that 27 or more bubbles are seen over the 2-minute test period on a butane system, or 32 or more bubbles are seen on a propane system (see Table D.2.).

### D.1 Preparations

1. Ensure all burner control taps, including any for pilot burner supplies, are turned off;
2. Ensure all appliance isolation valves and any additional in-line shut-off valves are open (on a cooker with a fold down lid, lift the lid to the fully open position to ensure activation of any safety shut-off valves);
3. Pressurise the installation by opening a cylinder valve;
4. Check all joints between the cylinder(s) connection and the ALDE Leak Detector, including any joints on the detector's by-pass arrangement (if fitted), for gas leaks using proprietary leak detection fluid complying with BS EN 14291. On completion, wipe off any remaining residues of leak detection fluid;

Note 1 If a leak is identified record a fail at Check 7.12.2 and follow the procedures at Appendix A. If the leak is from a high-pressure stage component also follow the Hazardous Boat procedures at Appendix B. Do not proceed with the test.

5. If a by-pass arrangement is fitted, ensure the valves are set to allow flow through the ALDE Leak Detector;
6. Purge the installation of air by igniting a small burner on each appliance until a steady flame is established. Turn off all burner control taps.

### D.2 Procedure: Fluid Check

1. Ignite a small burner (e.g. on gas hob / pilot burner);
2. Depress fully the test button, fit the proprietary clamp, and check for bubbles appearing in the fluid chamber;

Note 2 When the test button is depressed bubbles should appear in the fluid chamber thereby confirming that fluid is present and the detector is operating. Allow the bubbles to flow for at least 10 seconds. If no bubbles appear there may be insufficient fluid in the chamber or the detector may not be operating correctly. If no bubbles appear do not proceed with the test and record a fail at 7.12.1.

Note 3 When bubbles are seen during this fluid check procedure, but they are erratic in their flow rate or size, it is likely that the detector is faulty and it should therefore be taken that it is not operating correctly. Under such circumstances do not proceed with the test and record a fail at 7.12.1.

3. Turn off the small burner.

### D.3 Procedure: Tightness (Steady State Bubble) Test

1. With the ALDE's test button depressed continuously, carefully count any steady-state bubbles appearing in the fluid chamber over the following 2 minutes (the test period). Where seen, record the number of bubbles;
2. To pass the tightness test the number of steady bubbles counted over the 2 minute test period must be less than, or equal to, the maximum number of steady state bubbles given in Table D.1;

**Table D.1: Maximum Steady State Bubble Rate for a 'Pass'**

Maximum Number of Steady State Bubbles (bubbles in 2 minutes)	
Butane	3
Propane	4

Note 4 If the number of steady state bubbles counted over the 2-minute test period exceed the maximum number given in Table D.1:

- a. undertake the post-test procedure at D.4; and
- b. record a fail at 7.12.2; and
- c. follow the procedures at Appendix A; and,
- d. apply step D.5.

### D.4 Procedure: Post-Test

1. Ensure all cylinder valves are turned off;
2. Remove the proprietary clamp from the Detector;
3. If fitted, re-instate the flow through the Detector's by-pass arrangement;
4. Return in-line shut-off valve(s) and any appliance isolation valves to the position they were in prior to starting the test procedure.

### D.5 Hazardous Boat Activation

1. If the number of steady state bubbles counted over the 2-minute test period is greater than, or equal to, the number given in Table D.2 then the Hazardous Boat procedures at Appendix B must be followed.

**Table D.2: Minimum Steady State Bubble Rate for Hazardous Boat Activation**

Minimum Number of Steady State Bubbles for Hazardous Boat Activation (Bubbles In 2 mins)	
Butane	27
Propane	32





## **D1** Appendix – LPG Installations Tightness Testing Using A Pre-2008 Alde 4071 Leak Detector, Or Other Make Of Bubble Tester

This procedure applies to:

- pre-2008 ALDE 4071 Leak Detectors; or,
- any other make/model of bubble tester, i.e. Gaslox

For post-2008 ALDE 4071 Leak Detectors, Appendix D applies



**Figure 1.** A Gaslox bubble tester. Appendix D1 applies

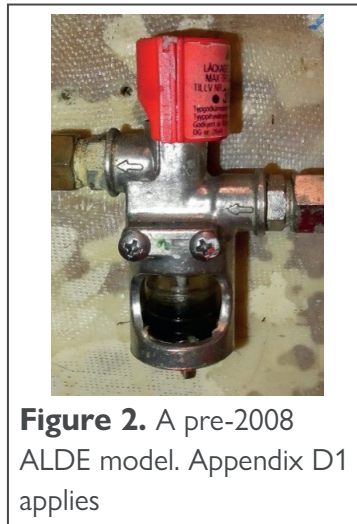

**Figure 2.** A pre-2008 ALDE model. Appendix D1 applies



**Figure 3.** Post 2008 ALDE Leak Detector. Appendix D applies

Examiners should apply the following preparatory sections from Appendix D:

- **Smell Of Gas On Board;**
- **Guidance On The Alde 4071 Leak Detector Test Procedure;**
- **D.1 - Preparations;**
- **D.2 - Procedure: Fluid Check.**

### **D.3 LPG-Tightness Test Procedure**

1. With the bubble tester's test button depressed continuously, carefully count any bubbles appearing in the fluid chamber over the following 60 seconds (the test period);
2. To pass the tightness test the number of bubbles counted over the 60 second test period must be zero.

Note 1: If bubbles are counted over the 60 second test period:

- a. undertake the post-test procedure at D.4; and
- b. record a fail at 7.12.2; and
- c. follow the procedures at Appendix A and Appendix B

### **D.4 Procedure: Post- Test**

1. Ensure all cylinder valves are turned off;
2. Remove any proprietary clamp from the bubble tester;
3. If fitted, re-instate the flow through the bubble testers by-pass arrangement;
4. Return in-line shut-off valve(s) and any appliance isolation valves to the position they were in prior to starting the test procedure.



### **Important Note**

**Flue spillage tests are to be undertaken on LPG appliances fitted with open flues which incorporate draught diverters. Spillage testing is not undertaken on LPG appliances with open flues not fitted with a draught diverter (sometimes referred to as closed flues), or on solid fuel or liquid fuelled appliances).**

**The procedures set out below are to be carried out where there are no manufacturer's recommendations available for testing the flue.**

### **E.1 Preparations**

Visual inspection of appliance;

Close all doors, windows, adjustable ventilators;

Turn off any extractor fans in the same or adjoining compartments;

Light the appliance and allow a 5 minute warm up period before starting the test;

Fix a smoke match into a smoke match holder; Note: If the flue passes this check it will be retested with these fans operating. See below at E.3.

### **E.2 Test Procedure**

Light the smoke match;

The match is lit and held 5-10mm inside the lower lip of the draught diverter or inside the edge of the canopy or smoke hood;

The match is moved to encompass as much of the draught diverter or canopy/smoke hood as possible;

All smoke should be drawn into the flue and removed to the outside air. Any temporary or momentary back-spillage may be discounted;

If continuous smoke spillage occurs allow a further warm-up period of 10 min and recheck as described above.

### **E.3 Re-Test With Any Extractor Fans In The Same Or Adjoining Compartments Operating**

Switch on any fan(s). If there is a fan in an adjoining compartment it should be operated with the connecting doors open.

#### **Carry Out Retest As Described Above**

All smoke should be drawn into the flue and removed to the outside air.

**Any Temporary Or Momentary Back-Spillage May Be Discounted.**

### **E.4 Post-Test Procedure**

Turn off the appliance and return the system to its pre-test condition.



## **F** Appendix – BSS 230V AC Safe Disconnection Process

---

Appendix F sets out the recommended 230V AC Safe Disconnection Process to be followed by BSS Examiners to confirm the boat is electrically dead before starting the BSS Examination.

The BSS has concluded that the only way to be certain that Examiners are not at risk from electrocution from 230V systems while they are performing a BSS Examination, especially those who are not competent electricians, is to make the boat 'electrically dead'. The 230V AC Safe Disconnection Process has been designed to support BSS Examiners to mitigate these risks.

BSS Examiners who are competent electricians and who provide electrical services as part of their business outside of the BSS can choose to adopt their own normal risk assessment practices and use their associated equipment, provided that any non-BSS advice or guidance issued, is the subject of a separate contract outside of the BSS Examination.

The following icons have been used to emphasise points which need extra attention:

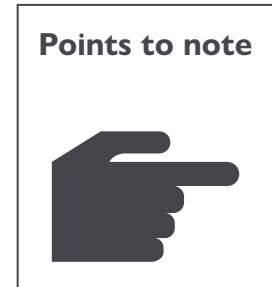

Appendix F starts with a flowchart, which is broken into colour bands.

After the flowchart is a step-by-step description of the process which needs to be followed.

The steps described are broken into the same colour bands as the flowchart.

### Flowchart of the BSS 230V AC Safe Disconnection Process

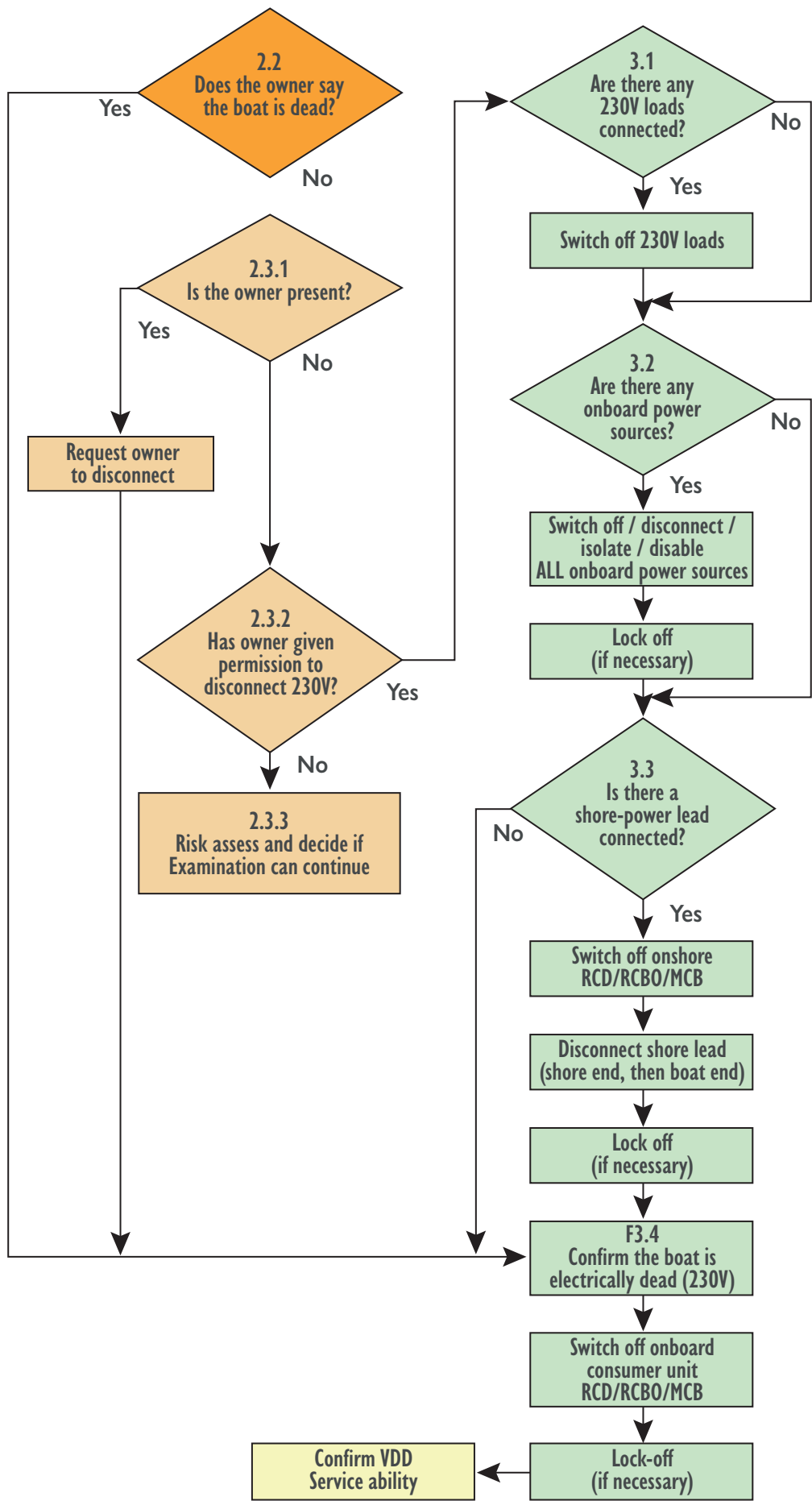

## F1. Before attending the boat



There is only one step for 'before attending the boat' and this should be done during the initial conversations with the owner to book the Examination.

The BSS 230V AC Safe Disconnection Process assumes that the boat owner or their representative will be on board to undertake certain key procedural steps. Therefore, whenever possible Examiners should work with their customers to make sure that the owner or their representative are present. However, in cases where this is not possible, Examiners may undertake the owner's tasks providing a suitable agreement has been reached with the owner.

Key points regarding this process which Examiners should have written in their Examination Agreement with Owner are that the owner should confirm:

- all 230V AC power sources (e.g. shore-power supplies and/or onboard power sources such as inverters and generators) and how to disconnect and re-energise;
- which are the critical AC loads and how to turn them off and on;
- that they are aware that the Examiner is not liable for any loss or damage, any incident or accident that may arise from undertaking the 230V disconnection or re-energisation, and that the owner retains overall responsibility for the process.

In the event the above agreements cannot be reached with an owner the Examiner should only proceed with the Examination once the boat owner or their representative can be present.



The disconnection and re-energisation Steps should be undertaken by the owner. If the owner is not present then they could be undertaken by the Examiner, as long as they have permission and enough information, and the Examiner feels safe to do so.

## F2. Onsite prior to disconnection



These steps are to be done onsite at the boat to be examined but before starting to perform the Examination and before the disconnection itself.

### 2.1 Confirm VDD serviceability

The tool Examiners are guided to use to check if the boat's electrical systems are dead or alive is a VDD. It is recommended that the Examiner has two VDDs in case one is found not to be working.



**For personal safety, the two VDDs (and the 16A to 13A adapter) should be visually checked to ensure that they are complete and free from damage or deterioration before commencing with the disconnection.**

**If the integrity of any of these items is compromised in any way, Examiners should not undertake the 230V system disconnection using these items or perform the BSS Examination.**

#### 2.1.1 Confirm the VDD's serviceability

Examiners should confirm that the voltage detection device (VDD) is functioning correctly by plugging it into a known operational power source. This confirmation should be done once at the location of the Examination with a live 230V plug socket, regardless of when it was last checked.

To establish its serviceability, insert the VDD into a known live power source (this could include the Examiner's own portable UPS or inverter) and if the:

1. VDD illuminates then this proves that the VDD is working correctly, and the Examiner may continue with the disconnection;
2. VDD does not illuminate then either the VDD is not working correctly or the 230V supply is not connected. To mitigate this issue the Examiner should:
  - a. try the VDD in an alternative socket, and if still not working; then,
  - b. check to see if any other 230V items have illuminated lights,
  - c. try the second VDD, and if still not working; then ,
  - d. ask the owner to confirm that the 230V is still live;
  - e. reconsider if it is safe to continue.



### **120V or 415V system is installed**

Where a 120V or 415V system is installed, or there are no suitable sockets onboard into which the VDD can be used, then the BSS Office should be called for guidance.

## **2.2 Does the owner state that the vessel is already disconnected?**



If the owner states that the vessel is already disconnected (including that any alternative and/or auto-start 230V power sources are disconnected or disabled), then go straight to point 3.4 to confirm that the boat is electrically dead.

## **2.3 Is the owner present or does the Examiner have permission to disconnect?**



The BSS recommends that Examiners have the owner, or their representative at every BSS Examination. However, they recognise that this is not always possible, and these Steps cover both the owner being there and not.

### **2.3.1 Owner is present**



1. If the owner is present, then the Examiner should request that the owner:
  - identifies all AC shore-power inlets; and,
  - identifies any other sources of AC electrical power on the boat e.g. generators and inverters.

Then the owner disconnects the 230V system(s).

2. If the owner confirms that they have disconnected the 230V system, then the Examiner should assume that the boat is still electrically alive and proceed to Step 3.4.

### **2.3.2 Owner 'not present' but Examiner has permission**



If the owner is not present, but the Examiner has permission to disconnect the 230V and to re-energise when the Examination is complete, then the Examiner should proceed as per their 'Examination Agreement with owner'.



**Before disconnecting any sources of power Examiners should consider if they have enough information, clear instructions and permission to re-energise in accordance with the owner's wishes.**



### **Equipment or an appliance is not operating as expected**

If the Examiner identifies that a piece of equipment or an appliance etc is not operating as expected, the Examiner should report it to the owner before carrying out a disconnection, so that the Examiner does not become liable for any damage.

### **2.3.3 Owner not present and Examiner does not have permission**



If the owner is not present and the Examiner does not have permission to disconnect the 230V then the Examiner should:

- assume that the 230V is live and not disconnected; and,
- reconsider if it is safe to continue with the BSS Examination.



## 2.4 Proceed with caution



Until the boat is established to be electrically dead, always **proceed with caution**.

Expect to find alternative connected power sources e.g. shore-power, generators and inverters including generators/inverters with auto start facilities.



Lone working safe practices, in this context, includes ensuring someone knows the duration of the examination and the location of the boat so that they can raise help if the Examiner does not confirm that they are safe by the time the examination is due to end.



If the Examiner does not feel safe at any stage of the disconnection process, then they should stop and:

- gather more information;
- decide if they are competent to calculate the level of risk;
- and if they feel unsafe in anyway then they should stop and not perform the Examination.

## F3. Disconnection Process

These steps are the disconnection itself and to be done after the VDD's serviceability has been confirmed and the instructions for disconnection and re-energising are clear and confirmed by the owner. Most of these steps are in the flowchart.

### 3.1 Are there any 230V loads connected onboard the boat?

If there are any 230V loads connected that require shutting down before disconnecting the power, then:

- a. before disconnecting anything, using the VDD confirm that a selection of sockets is live. A selection could be described as port, starboard and in each accommodation space with power sockets;
- b. switch off all the boat's 230V electrical **appliances**, equipment, and devices. **Leave sockets Live**

### 3.2 Are there any onboard 230V power sources present?

If there are any onboard 230V power sources present, then:

- a. disconnect all onboard power sources e.g. generators and inverters, including generators/inverters with auto start facilities;
- b. if these power sources cannot be disconnected then the boat will not be able to become electrically dead, and in these circumstances before undertaking the BSS Examination, the Examiner should reconsider if it is safe to continue.



**Not all inverter DC supplies will be routed through a battery isolation switch. In such cases disconnection of the (AC) output will be achieved solely by switching the inverter's 'on/off' switch to 'off'.**



**Where inverters are fitted, wait at least 5 minutes after disconnecting the shore-power and/or the inverter before continuing, otherwise a danger of electrocution may be present.**

### 3.3 Is there a shore-power lead connected to the boat?

- a. switch off onshore RCD / RCBO / MCB; and then,
- b. disconnect the shore-power lead shore-end first and then boat-end second;
- c. if it is practical then coil the shore-power lead and put it inside the boat;
- d. where needed implement additional techniques to prevent inadvertent reconnection.

Note: on rare occasions there may be two shore-power leads



**Examiners should be aware that shore-power leads tend to deteriorate and then fall apart, and therefore Examiners must **proceed with caution before disconnecting.****

### 3.4 Confirm the boat is electrically dead

Once the Examiner believes that all sources of 230V have been disconnected, then the Examiner needs to confirm that the boat is 'electrically dead'.

#### 3.4.1 Use VDD to confirm if the boat is electrically dead

Insert the VDD into a selection of the boat's 230V sockets to confirm they do not have power to them, and therefore are dead. Examiners may choose to test the same sockets as used at Step 3.1 prior to disconnection, in case they are testing for live power in a socket which is not normally in service.

##### 3.4.1.1 If the VDD does not illuminate – check in a live 230V source

If the VDD does not illuminate, then either the VDD is not working correctly or the 230V supply is not connected.

To be certain that the boat is dead then **the VDD's serviceability needs to be confirmed** by checking it in a live 230V known source.

##### 3.4.1.2 If the VDD does illuminate

If the VDD does illuminate, then safe disconnection has **not** been achieved. In such circumstances:

- a. go back to the start of Step F3, and request that the boat owner reassesses the possible additional sources of AC electrical power;
- b. If the disconnection has been unsuccessful on a number of consecutive attempts, then the Examiner should consider if it is safe to continue with the BSS Examination.

#### 3.4.2 Switch off onboard consumer unit

- a. where there is an AC consumer unit with RCD / RCBO / MCB installed within the boat, request the owner switches off the main RCD / RCBO / MCB isolator switch;
- b. the consumer unit can be locked off at this point to prevent inadvertent reconnection, if necessary.

### F4. Perform the BSS Examination

Once the boat has been proven dead, the Examiner can proceed with the BSS Examination.

Boat cabin lights normally operate on 12V DC, or 24V DC and so the Examiner should still be able to see to safely complete the Examination, however if not then a torch can be used. Therefore, it is recommended that all Examiners carry a torch in their standard Examination tool kit.

### F5. Re-energisation

Once the BSS Examination is complete, then re-energisation should be considered, as long as there were no issues found which would prevent a safe re-energisation.

#### 5.1 Is the owner present or has the Examiner got permission to re-energise?

##### 5.1.1 Owner is present

If the owner is present, then the Examiner should request that the owner re-energises as per the process in Step 5.3 below.

The Examiner does not need to wait onsite until the re-energisation is complete, though they of course may choose to. Note that it is not the Examiner's responsibility to resolve any re-energisation issues.

##### 5.1.2 Owner not present but Examiner has permission to re-energise

If the owner is not present, but the Examiner has permission to re-energise, preferably in writing, then the Examiner should proceed as per the 'Examination agreement with owner', which may include reconnecting any 230V loads (appliances etc.) that were turned off before the 230V was disconnected.

If the electrical systems do not re-energise as expected, then the Examiner should contact the owner.

### 5.1.3 Owner not present and Examiner does not have permission

If the Examiner decided to go ahead with the Examination (because the boat was already electrically dead, or the risk assessment showed that it was safe to do so), even if the owner did not give permission to disconnect or re-energise, then Examiners should not reconnect or re-energise any part of the electrical systems.

## 5.2 Safely re-energising the electrical system(s)



**If, during the BSS Examination, a Warning Notice was issued at ECP check 3.9.1 ‘Is it impossible to connect simultaneously more than one power source to the AC distribution system?’, it is strongly recommended that Examiners do not to re-energise the 230V systems themselves, nor should they support the owner to do so.**

**Examiners should leave the 230V system de-energised. If the owner is not present, then they should be notified that the system is not energised.**

## 5.3 The process of re-energising

Once the BSS Examination is complete, and provided an electrical related Warning Notice has not been issued, the boat’s electrical systems (AC, and DC to AC inverters) may need to be re-energised.

It is recommended that the owner re-energises.

### The recommended re-energisation process:

1. Refer to the owner’s reconnection process as per the ‘Examination agreement with owner;
2. Reconnect the shore-power lead (boat-end first and then the shore-end second), as long as the shore-power lead and connectors are not subject to a BSS Warning Notice at ECP Check 3.8.1, or Check 3.8.2 or Check 3.8.3;
3. Remove the lock-off device if fitted at Step 3.3.d from the onshore RCD / RCBO / MCB isolator switch;
4. Switch on any onshore RCD / RCBO / MCB;
5. If the boat has a consumer unit with RCD / RCBO / MCB, then:
  - a. Remove any lock-off device fitted at Step 3.1.d from the main RCD / RCBO / MCB isolator switch, if installed;
  - b. Switch on the main RCD / RCBO / MCB isolator switch;
  - c. Re-establish all AC loads switched off at Step 3.1.a, b and c;
6. Re-energise all onboard power sources e.g. generators and inverters, including generators/ inverters with auto start facilities switched off at Step 3.2.a.

## 5.4 Confirm successful re-energisation using the VDD

To ensure that the 230V system re-energisation has happened correctly, use the VDD in the same sockets as tested before disconnection, as described at ‘3.4.1 VDD to confirm if the boat is electrically dead’.

If the VDD does illuminate, then this is confirmation that the socket is live.

If the VDD does not illuminate, then see ‘2.1.1 Confirm the VDD’s serviceability’ and if the VDD is found to be serviceable, then repeat the process from 5.3.

The Examiner may also check for the illumination of indicator lights on 230V equipment.



### Equipment or an appliance is not operating as expected

If the Examiner identifies that a piece of equipment or an appliance etc is not operating as expected, the Examiner should report it to the owner before leaving the boat or as soon as practical, so that the Examiner does not become liable for any damage.



## **G** Appendix – Disabled, Decommissioned Or Disconnected Systems

The information below provides guidance to Examiners on how to apply the Examination Checking Procedures to disabled or decommissioned or disconnected systems or equipment, or systems that appear to have components or appliances removed or missing (v1.0 June 2012).

<b>1.0</b>	<b>Introduction</b>
1.1	Guidance to BSS Examiners about making sure in advance of the examination that the owner presents the vessel with water, gas, and electrical systems in working order and with all required items capable of being checked effectively, is covered in the 'pre-examination' section.
1.2	The purpose of this particular note is to provide guidance covering those situations where, during an examination, systems, system components, appliances or items which are the subject of BSS Checks are not present, disabled or decommissioned or disconnected.  The aim of the note is to help ensure that full and complete BSS Examinations can be carried out.
1.3	The guidance is relevant to the following circumstances: <ul style="list-style-type: none"> <li>• systems components, engines, appliances or other items subject to BSS Checks that appear to have been removed or are missing, but a fuel supply is in place;</li> <li>• systems, system components, engines, appliances or other items, subject to BSS Checks are being worked on or are disconnected, unfinished or in some other way non-functioning;</li> <li>• where the owner is seeking to retain a disconnected or permanently disabled or decommissioned engine or appliance.</li> </ul>
<b>2.0</b>	<b>Pre BSS Examination Guidance to Owners</b>
2.1	Owners are responsible for preparing their vessels for a BSS Examination. It is in their interests to do this as diligently as possible so as to keep to a minimum the time necessary for an examination to be carried out.
2.2	It is essential that, as part of an Examiner's ordinary procedures when making arrangements for BSS Examinations with an owner or their representative, owners are reminded that BSS Certificates cannot be issued unless a vessel is fitted with at least one complete system e.g. a propulsion engine and its fuel supply, and verified as being compliant in accordance with the BSS Examination Checking Procedures.
<b>3.0</b>	<b>Accepted principles</b>
3.1	Unless covered specifically in the detailed guidance in section 4 below the following accepted principles apply if the circumstances as described at 1.3 are encountered: <ul style="list-style-type: none"> <li>• The BSS examination and BSS Certificate issue represents a 'snapshot in time' and it is accepted that boats may take a very long time to fully fit out, and will undergo refits and modifications throughout their lives;</li> <li>• BSS Certificates cannot be issued unless a vessel is fitted with at least one complete system e.g. a propulsion engine and its fuel supply, and this verified as being compliant in accordance with the BSS Examination Checking Procedures;</li> <li>• Boat owners are responsible for making the boat available in a condition that can be examined, including the vessel having water, gas, and electrical systems in working order, sufficient to ensure that all required items subject to examination are capable of being checked effectively. There is no evidence to suggest that part finished boats or boats undergoing refit present a heightened risk of fire or explosion;</li> <li>• Items that are not present to examine cannot be examined;</li> <li>• Boat owners are responsible to ensure that any changes they make in between examinations are to the BSS Requirements. This work is assessed at the next BSS examination;</li> <li>• Redundant pipework or wiring found on board but confirmed as not connected to a supply or appliance should be ignored for the purposes of the BSS.</li> </ul>

<b>4.0</b>	<b>General approach</b>
4.1	<p>Unless covered specifically in the detailed guidance in Section 5 below, the following general approach applies if the circumstances as described at 1.3 are encountered: Items such as engines, appliances or their component items or systems found not present, disconnected, disabled or decommissioned can be considered as 'not present' for the purposes of the BSS examination if:</p> <ol style="list-style-type: none"> <li>the item is removed from the boat; or,</li> <li>the item is in fact or is made 'inactive*' and to make it active again will require re-connection, replacement or modification of such items using tools.</li> </ol> <p>* defined as not functioning or operating; out of use.</p>
4.2	Where the above general approach has been applied and for the purposes of recording examinations, the engine/appliance or system is to be recorded as 'not present' and a note of the circumstances must be retained with the examination record.
4.3	In the event the above guidance does not give full clarity, seek advice from the BSS Office.
<b>5.0</b>	<b>Guidance specific to particular items or circumstances</b>
5.1	<p><b>5.1.1 Batteries</b></p> <p>Boats which are provided with arrangements for the installation of engine start and/or domestic batteries must have their batteries installed at the time of any BSS Examination. Where the required batteries are found not to be fitted an Examination cannot be completed until batteries have been installed and the relevant Checks can be carried out, unless guidance has been taken from the BSS Office.</p>
	<p><b>5.1.2 Electrical wiring</b></p> <p>In the event electrical wiring is found not connected to electrical equipment but is confirmed as connected to the distribution/fuse box, any examination cannot be completed:</p> <ul style="list-style-type: none"> <li>unless the electrical equipment has been properly connected to an appliance or terminal block or other proprietary connector; or,</li> <li>unless the electrical wiring has been completely removed back to the distribution/fuse box; [Note removal of a fuse or circuit breaker does not constitute making the circuit inactive]</li> <li>unless guidance has been taken from the BSS Office.</li> </ul>
<b>5.2</b>	<b>LPG Systems and Appliances</b>
5.2	<p><b>5.2.1 Gas appliances found but no cylinder or cylinder locker and/or no supply pipework.</b></p> <p>Boats which have a gas appliance(s) but no cylinder or cylinder locker or obvious location for open cylinder stowage and possibly no supply pipework, must be treated cautiously because of the potential for cylinders to be subsequently located inside the accommodation space not in a locker.</p> <p>In these circumstances a BSS Examination cannot be completed:</p> <ol style="list-style-type: none"> <li>until the LPG cylinders and supply pipework is in place or the gas appliance is removed; or,</li> <li>unless guidance has been taken from the BSS Office.</li> </ol>
	<p><b>5.2.2 Non-compliant LPG fridges on petrol engine boats</b></p> <p>Non room-sealed dual (electric/LPG) fuelled refrigerators installed in boats with petrol propulsion engines may not be provided with any LPG supply pipework unless the burner, combustion air and exhaust arrangements comply with the BSS Requirements.</p> <p>In the event that a non-compliant LPG dual-fuel refrigerator is retained by the owner for use solely with electric or as storage, examinations may only be completed when any fridge LPG supply pipework and/or hose is removed at least to the branch 'T' joint with the supply line. The T-joint should ideally be replaced with an in-line or elbow joint or the pipe replaced with a continuous length. The use of a stop-end to a short length of supported spur pipe is acceptable.</p>

### Permanently installed fuel systems and fixed engines

#### 1 – Essential material needed by BSS Examiners to be able to apply certain Part 2 Checks

##### 1.1 Kerosene, Paraffin and Petroil

The BSS Requirements apply to kerosene and paraffin installations in the same way they do for diesel installations. Therefore, during BSS Examinations Examiners must apply the Checks to kerosene or paraffin installations as if they were diesel installations.

The BSS Requirements apply to petroil engines in the same way they do for petrol engines. Therefore, during BSS Examinations Examiners must apply the Checks to petroil engines as if they were petrol engines.

See further information at section 2.1 covering the characteristics of kerosene, paraffin and petroil.

##### 1.2 Vintage and unusual engine types

Vintage marine engines may be fuelled by spark-ignited paraffin, or a combination of petrol and paraffin. In the event Examiners are unsure as to how to apply the BSS Requirements to such engines they should contact the BSS Office for guidance. The same applies to any other marine engine that is not obviously fuelled by petrol or diesel.

##### 1.3 International symbols (for fuel types)

At Check 2.1.1 it is acceptable for fuel filling points to be marked with an appropriate internationally recognised fuel symbol (from ISO 7000 – graphical symbols for use on equipment) rather than words describing the fuel type. The three most common symbols are shown below:



Examiners are not required to determine the type of petrol in use (e.g. whether it's unleaded) and so do not have to determine whether the correct petrol symbol is present.

##### 1.4 Fuel tanks – unsuitable materials

The Requirement at Check 2.5.2 specifies that fuel tanks must not be made from obviously unsuitable materials.

Materials obviously unsuitable for diesel include:

- Plastic tanks that are not 'CE' or 'UKCA' marked or otherwise recognised as being suitable (see item 1.5, below);
- Copper based alloys (e.g. brass).

Materials obviously unsuitable for petrol include:

- Plastic tanks that are not 'CE' or 'UKCA' marked or otherwise recognised as being suitable (see item 1.5, below);
- Mild steel;
- FRP/GRP.



## Appendix 2

### Essential Information

Metal coated (e.g. galvanised or aluminised steel) tanks:

Examiners must take care when examining tanks that are, or appear to be, metal coated.

Tanks with aluminised steel surfaces internally are suitable for petrol and diesel, whereas mild steel tanks hot-dip zinc-coated (galvanised) internally are suitable for petrol, but not for diesel. However, Examiners are unlikely to be able to confirm during an Examination whether a tank metal coated externally is metal coated internally. Therefore:

Petrol tanks – Examiners may accept externally metal coated (e.g. galvanised or aluminised steel) petrol tanks as being suitable at Check 2.5.2.

Diesel tanks – Examiners may accept externally metal coated (e.g. galvanised or aluminised steel) diesel tanks as being suitable at Check 2.5.2 provided the condition Requirements at Check 2.5.3 are met (see the 3rd Applicability at Check 2.5.2).

### 1.5 Fuel tanks – plastic tank suitability

All fuel tanks intended for use in recreational craft within the scope of the Recreational Craft Directive/Regulations must carry a 'CE' or 'UKCA' marking of conformity. They are also likely to be marked 'ISO 21487' (the RCD harmonised international standard for permanently installed petrol and diesel tank construction).



Plastic tanks marked in this way are compliant with the Requirement at Check 2.5.2.

Plastic tanks intended for use in boats outside of the scope of the Recreational Craft Directive/Regulations may also be accepted as being compliant at Check 2.5.2 if they have been manufactured to alternative appropriate specification. Most standards or codes relating to marine fuel tanks include a clause requiring the product to be marked with the manufacturer's details, fuel type(s) for which the tank is suitable, design capacity, test pressure and the standard or code number.

An example of an acceptable alternative to CE marking under the RCD/UKCA marking under the RCR is the US Coast Guard Code of Federal Regulations (CFR) Part 183.510 of 33 CFR, subpart J. Conformity with this code can be determined by a visual inspection of the tank manufacturer's plate, which should refer to the CFR Part 183.510, or any one of the following voluntary codes:

- American Boat and Yacht Council (ABYC) H24 and H33. (N.B. H33 refers to diesel systems and stipulates the same procedures as for petrol systems);
- American National Standards Institute/Underwriters Laboratories (ANSI/UL) 1102.1991;
- National Fire Protection Association (NFPA) fire protection standard for pleasure and commercial motor craft - NFPA 302.

Plastic tanks marked with any of the above are compliant with the Requirement at Check 2.5.2.

Where Examiners come across plastic tanks that are not CE marked to the RCD/UKCA marking under the RCR, or not marked with one of the alternative acceptable standards/codes listed above, they should contact the BSS Office for guidance.

### 1.6 Fuel tanks – plastic tank damage or deterioration

'Damage or deterioration' (ECP Glossary term) is that materially affecting, or likely to affect, the integrity, efficiency, or operation of an item or device. The following are indicators of damage or deterioration on plastic fuel tanks:

- Chafing, irregular indentations or punctures;
- Signs of corrosion attack (such as softening or environmental stress cracking);



- Softening indicates corrosive attack by the fuel causing the fuel to permeate the plastic or tank gasket material. The physical properties of the material will progressively degrade and may ultimately lead to tank failure or fuel leaks. The presence of softening would indicate that the tank is not being used in accordance with its intended purpose.

Environmental stress cracking may develop should the tank be subject to tension or bending stress beyond its design tolerance and over prolonged periods. Environmental stress cracks may cause fuel leaks.

Potential areas of stress cracking can be:

- adjacent to a tank spigot;
- next to a means to restrain the tank;
- around a tight radius in the moulded tank surface.

Any form of damage or deterioration on a plastic tank must be considered non-compliant (at Check 2.5.3) and unsafe.

### **1.7 Internal combustion engines housed in proprietary cocoons**

Examiners are not required to apply any of the Part 2 Checks to internal combustion engines housed within the original equipment manufacturer's cocoon – see the examples below. However, as described in the Applicability at Check 2.15.1, for such arrangements the engine mounting Requirements apply to the cocoon's mounting system where this can be seen on the outside of the cocoon.

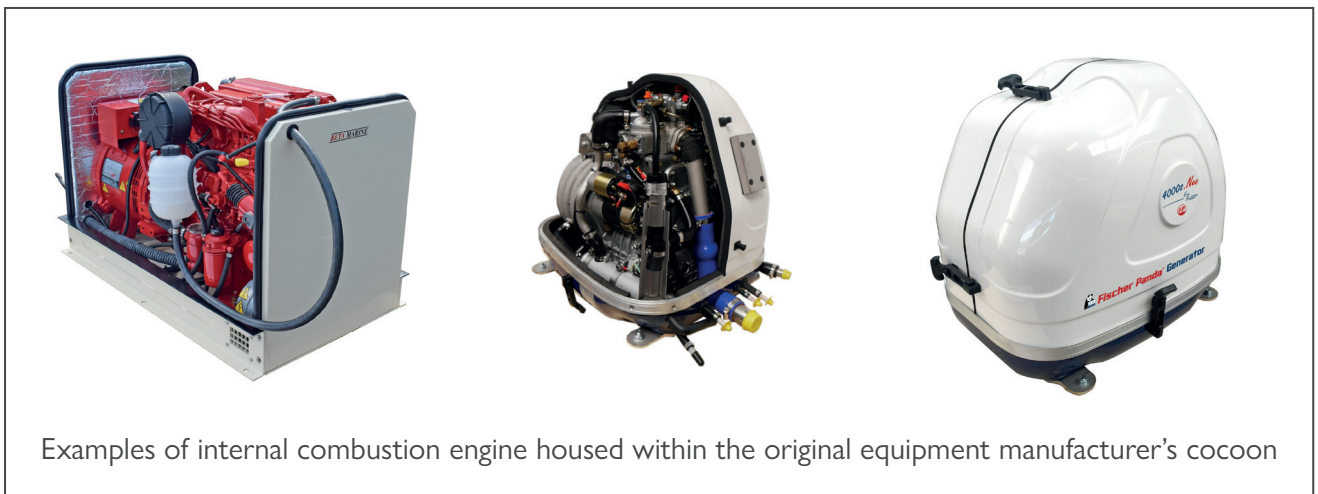

## **2 – Additional information to support BSS Examiners’ understanding of the BSS Requirements**

### **2.1 The nature of petrol, petroil, diesel, kerosene and paraffin**

#### **Petrol**

Petrol has a flashpoint of less than 0°C which makes it an ‘extremely flammable’ liquid. At normal environmental temperatures in the UK petrol therefore evaporates easily and quickly into the atmosphere. The vapours given off are three to four times heavier than air and will therefore sink to the lowest level of their surroundings (e.g. in cockpits, cabins, lockers and bilges).

For petrol vapour to ignite in air, the mixture of vapours must fall within certain concentrations, known as the flammable range (further defined as the upper and lower explosive limits). For petrol concentrations below 1.4% in air the mixture is too lean to ignite, and for those above 7.6% the concentration is too rich. At all concentrations between these two limits, a mixture of petrol vapour and air will burn. Hence whenever petrol vapours are released, although they may be too rich initially to burn, they will always pass through the flammable range to give a mixture that is capable of being ignited before they are eventually diluted to safe levels. If vapour within the flammable range is present in a confined space an explosion will result from ignition.

How long flammable concentrations of vapours persist and how far they travel before being diluted to a safe level will depend on the rate of release of the vapours and the level of ventilation acting to disperse them.

Petrol vapours will not only be released from any spilt product but, because of the ease with which it evaporates, they are released in significant quantities whenever petrol is handled, dispensed or transferred from one container to another. As a consequence of the flammable limits, petrol vapour when diluted 70-fold with air will still give rise to a flammable mixture and it can be calculated that one litre of petrol can, on evaporation, give rise to approximately 15 cubic metres of a flammable petrol/air mixture.

#### **Petroil**

Petroil is petrol to which has been added a small proportion of oil, used as a combined fuel and lubricant in some two-stroke engines. The nature of petroil is very similar to that of petrol, and therefore the risks associated with its use are also very similar. For the purposes of the BSS Requirements petroil and petroil engines are assessed in the same ways as petrol and equivalent petrol engines. Petroil is sometimes referred to as ‘premix’.

#### **Diesel**

Diesel has a flashpoint of approximately 50°C, which makes it a ‘flammable’ liquid. This reasonably high flashpoint means that at normal environmental temperatures in the UK diesel does not evaporate into the atmosphere. This means that diesel is considered as a relatively low volatile fuel and as such does not need the same controls in place to reduce the chance of ignition as is the case with more volatile petrol.

#### **Kerosene and paraffin**

Kerosene and paraffin are very similar fuel oils, and in the UK kerosene is often referred to as paraffin. In general terms paraffin is a more refined and distilled version of kerosene. Paraffin also usually contains additives that help reduce the odours given off by kerosene. In the UK kerosene is widely used as domestic heating oil.

Kerosene has a flashpoint of approximately 40°C, which makes it a ‘flammable’ liquid. So as with diesel, this reasonably high flashpoint means that at normal environmental temperatures in the UK kerosene does not evaporate into the atmosphere and therefore does not need the same control in place to reduce the chance of ignition as with petrol.

## 2.2 Fuel tank vent facility arrangements

At Check 2.3.1 a vent line must be fitted to each fuel tank, or a vent must be fitted to either the filling cap, filling line or tank top. The following drawings are intended to add clarity to the different acceptable arrangements that Examiners are likely to come across.

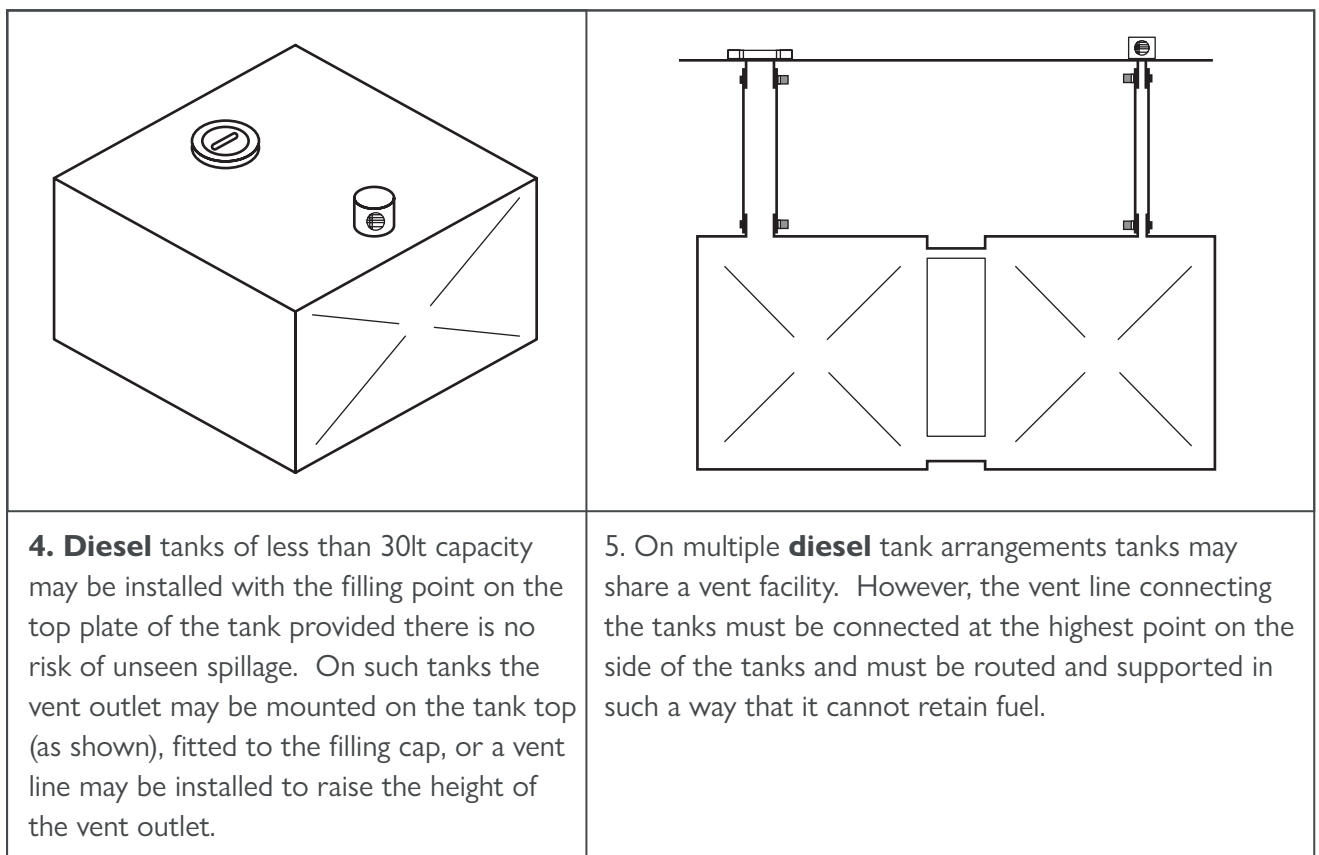
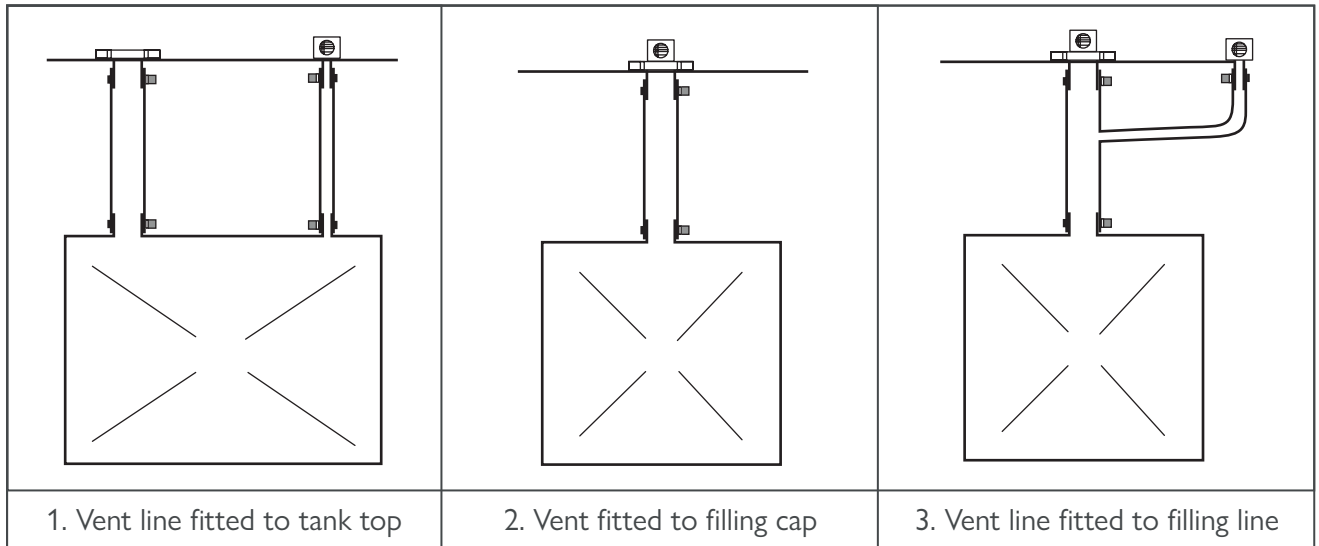

On tanks that are external to the interior of the vessel (e.g. on narrowboats with the fuel tank built into the stern counter), it is not uncommon for the filling point and the vent to be mounted on the tank top. On such tanks, for compliance the vent outlet may be mounted on the tank top (provided its opening is not lower than the opening of the filling point), fitted to the filling cap, or a vent line may be installed to raise the height of the vent outlet.

**Appendix 2**  
Additional Information

**2.3 Petrol tank vent outlet suitable proprietary flame arrestors**

At Check 2.4.2 petrol tank vent outlets must be fitted with a suitable proprietary flame arrestor. Examiners must be careful not to mistake a water tank vent outlet for a suitable proprietary flame arrestor. Some water tank vent outlets are provided with a coarse mesh to restrict debris and insect ingress which is not fine enough to act as a flame arrestor.

		
<p>Water tank outlet with a mesh of less than 11 wires/cm</p> <p style="text-align: right;"></p>	<p>Proprietary flame arrestors with a mesh of exactly 11 wires/cm</p> <p style="text-align: right;"></p>	<p>Proprietary flame arrestor with a mesh of greater than 11 wires/cm</p> <p style="text-align: right;"></p>

## Permanently installed fuel systems and fixed engines

### BSS Requirements for diesel leak-off (a.k.a. spill lines, spill rails and spill racks) arrangements (Check 2.10.5).

#### Primary compliance option

When checking diesel leak-off arrangements Examiners should start by applying the relevant Checks at 2.10.1-4 and 2.11.1-3. If the individual fuel lines and connections that make up the leak-off rack comply with the relevant Checks at 2.10.1-4 and 2.11.1-3 the leak-off arrangements are compliant at Check 2.10.5. Alternatively, if the individual fuel lines and connections that make up the leak-off rack do not comply with the relevant Checks at 2.10.1-4 and 2.11.1-3 the leak-off arrangement may achieve compliance using one or more of the following three options:

#### Alternative compliance options

##### Option 1 – Fuel within the leak-off rack returns to the main fuel system on the engine through non-return valve

To achieve compliance using Option 1, the leak-off rack must be connected to the main fuel system on the engine through a non-return valve. (Such a non-return valve will stop fuel from the main fuel system entering the leak-off rack.) The following Requirements also apply:

- The leak-off components must all be original to the engine; and
- The leak-off components must be free of signs of leaks, damage or deterioration.

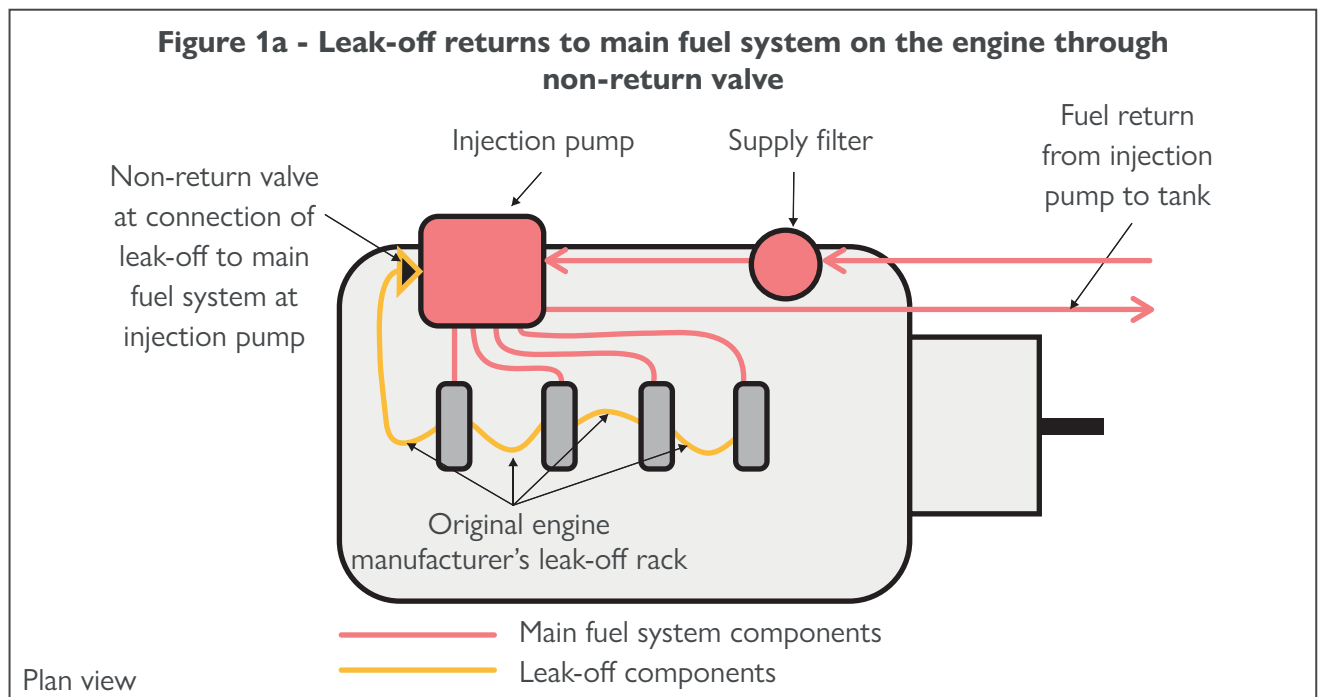

**Example 1** – Figure 1a shows an example of an arrangement compliant with Option 1. The leak-off rack connects into the main fuel system at the injection pump through a non-return valve.

**Figure 1b - Leak-off returns to main fuel system on the engine through non-return valve**

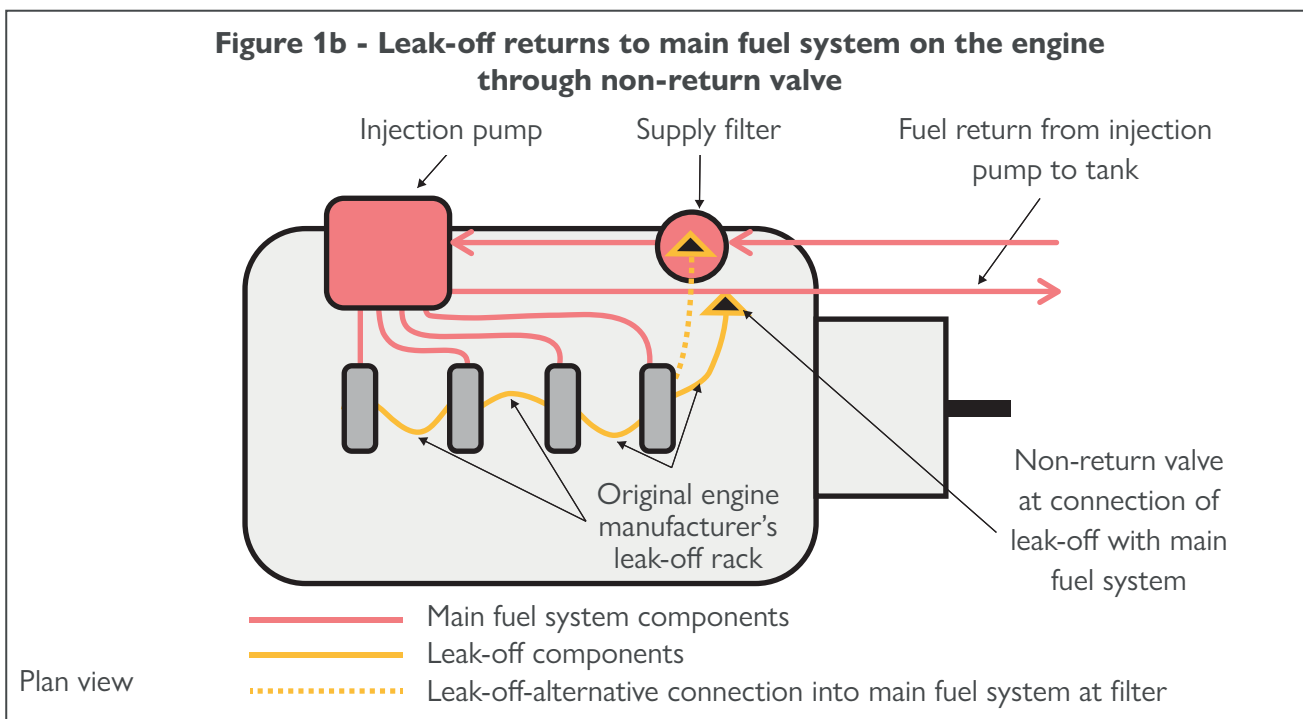

**Example 2** – Figure 1b shows two further examples of a leak-off rack compliant with Option 1. The main drawing shows the leak-off rack connecting into the main fuel system with a non-return valve on the return line from the injection pump to the tank. The yellow-dotted line shows the leak-off rack connecting into the main fuel supply with a non-return valve at the supply filter.

**Figure 1c - Leak-off returns to main fuel system on the engine through non-return valve**

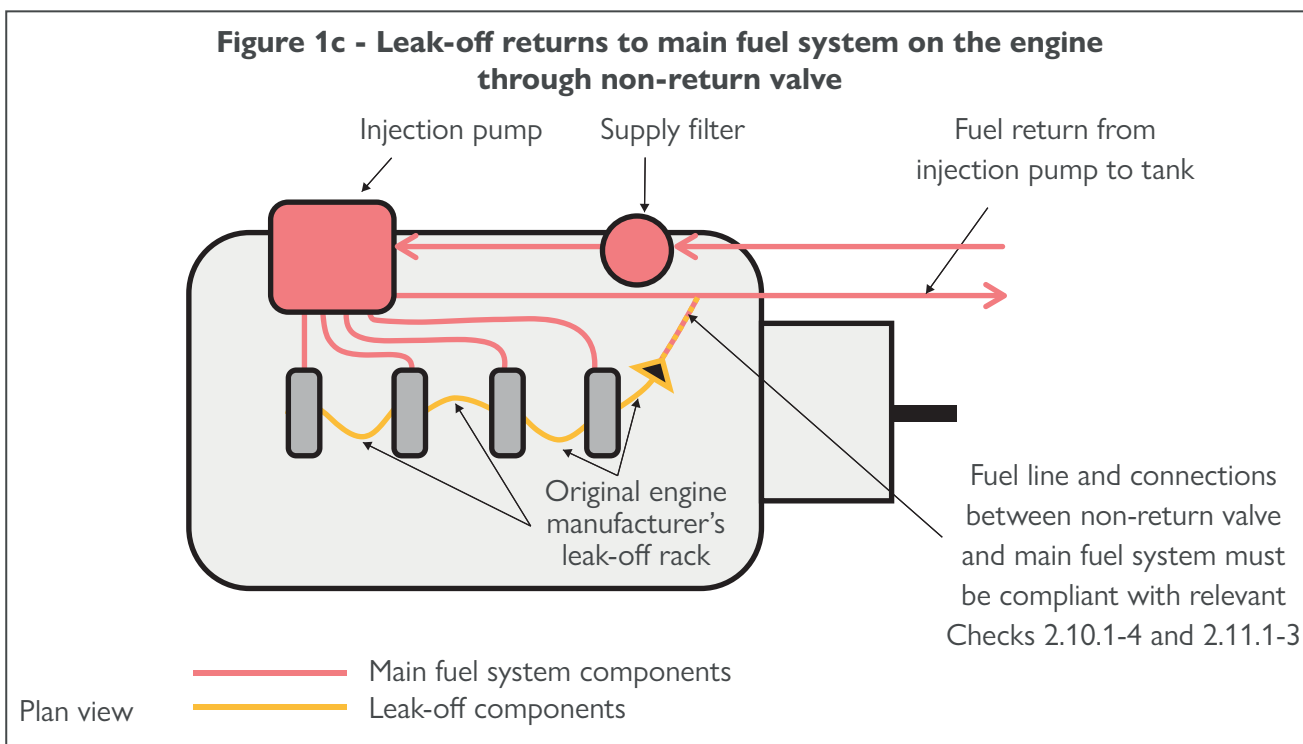

**Example 3** – Figure 1c shows a further example of a leak-off rack compliant with Option 1. Here the non-return valve is in the fuel line between the final injector and the injection pump return line to the tank. The fuel line between the final injector and the non-return valve is part of the original engine leak-off arrangement. However, as the non-return valve only protects the leak-off arrangements upstream of it, the fuel line between the non-return valve and the connection into the main fuel system must be compliant with the relevant Requirements at Checks 2.10.1-4 and 2.11.1-3.

**Option 2 – Leak-off returns to the tank through a non-return valve**

To achieve compliance using Option 2, the on-engine leak-off rack must be connected directly to the top plate of the tank by a dedicated fuel return line. A non-return valve must be installed in the return line to prevent fuel from the tank syphoning back into the on-engine leak-off rack. (The non-return valve may be located at any point along the fuel return line.) The following Requirements also apply:

- The leak-off rack on the engine must all be original to the engine; and
- The leak-off rack components must be free of signs of leaks, damage or deterioration; and
- The connection between the original on-engine leak-off rack and the dedicated return line must be made on the engine; and
- The dedicated return line including its connections to the on-engine leak-off rack and the tank must be compliant with Checks 2.10.1-4 and 2.11.1-3.

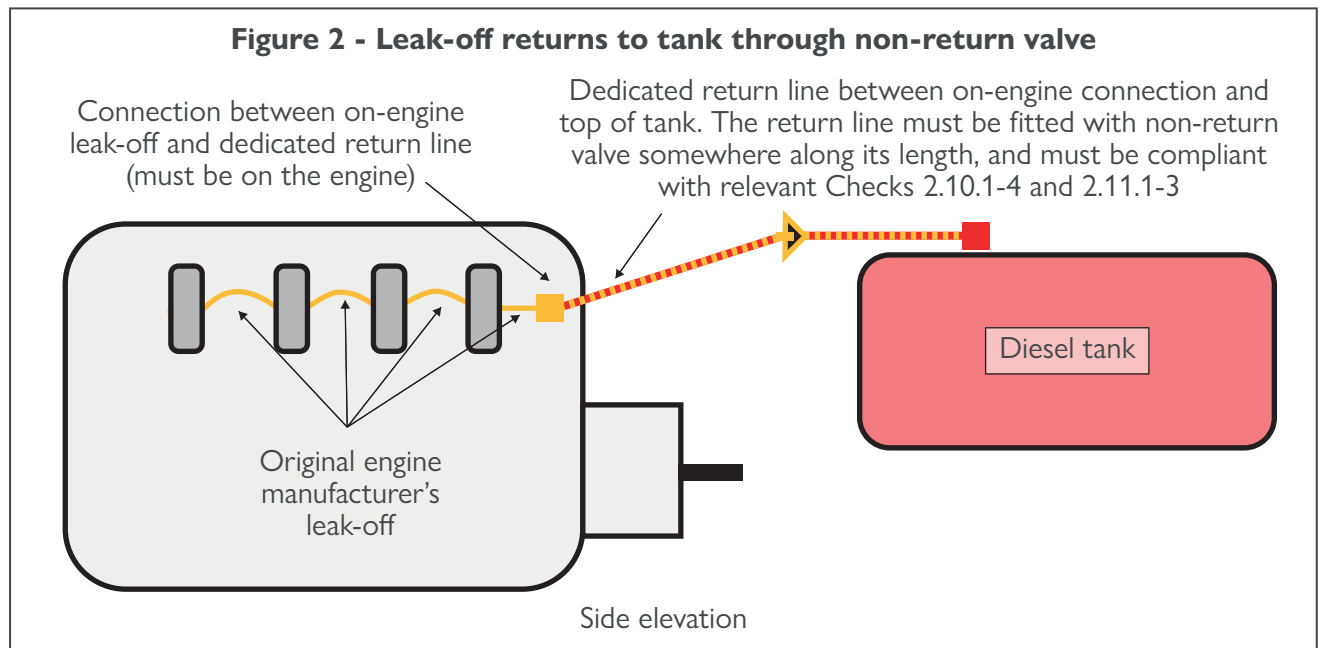



### Option 3 – Leak-off returns to the tank by gravity

To achieve compliance using Option 3, the leak-off must be connected directly by a dedicated fuel return line to the top plate of the tank, with the tank connection being below the level of the leak-off connection on the final injector. The fuel return line must be self-draining from the aft injector to the tank.

Such an arrangement will prevent fuel from the tank syphoning back into the leak-off rack.

The following Requirements also apply:

- The leak-off rack on the engine must all be original to the engine; and
- The leak-off rack components must be free of signs of leaks, damage or deterioration; and
- The connection between the original on-engine leak-off rack and the dedicated return line must be made on the engine; and
- The dedicated return line including its connections to the on-engine leak-off rack and the tank must be compliant with Checks 2.10.1-4 and 2.11.1-3.

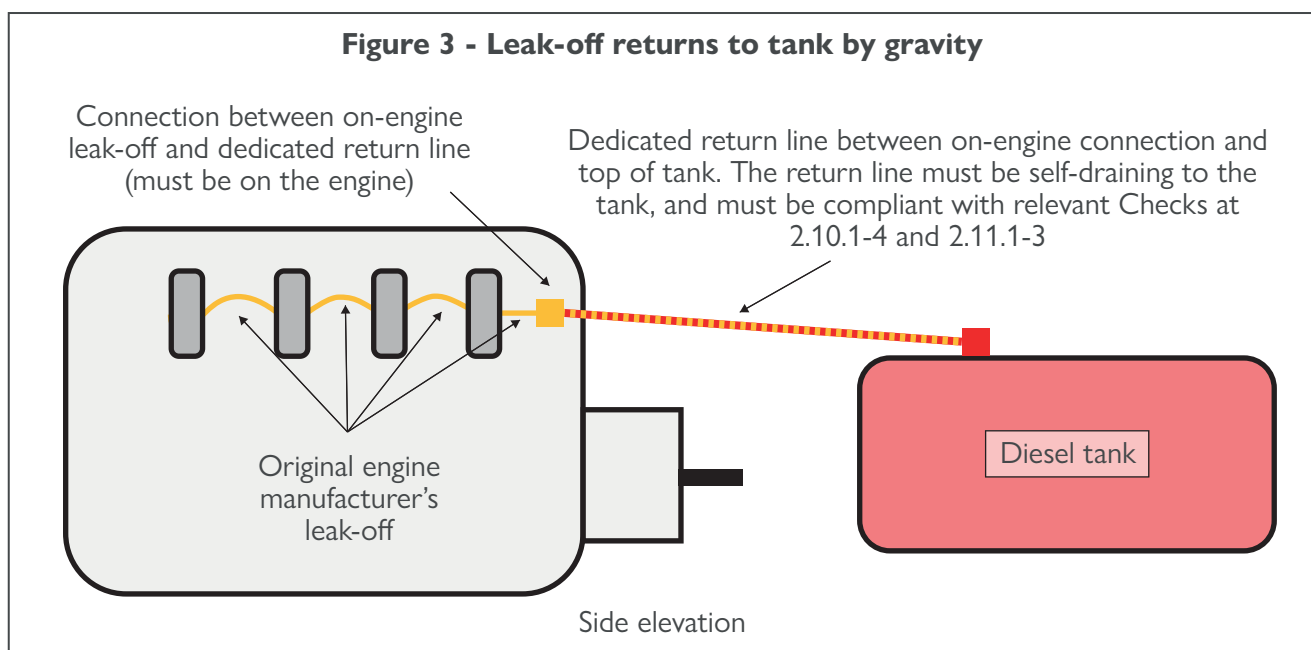



### **Permanently installed fuel systems and fixed engines**

#### **BSS Requirements for steam engine pressure system inspection certificates (Check 2.16.1)**

**The inspection certificate is actually a detailed report of an examination of a pressure system which may involve a number of stages and tests and the report may be issued in two parts.**

There is no set format for the report although HSE does publish a model form, the reports are issued by organisations (often an insurance company) and professional independent competent persons.

In all cases the reports will be signed by a person with a title such as:

- tester;
- examiner;
- inspector;
- surveyor;
- engineer surveyor.

A report will be issued whatever the state of the boiler as its purpose is to tell the owner what is wrong as well as what is right. The existence of a report does not mean, therefore, that the boiler is in a satisfactory state to be used, so it must be read carefully.

### **Report Assessment**

**You must be assured of the following:**

- has the examination been carried out by a competent person; and,
- does the report indicate satisfactory condition?

### **Competent Person**

**Any person issuing a report on behalf of one of the following may be accepted as competent:**

- insurance companies;
- plant examination firms;
- inspector;
- SBA Services Ltd;
- Northern or Southern Federations of Model Engineering Societies.

In the case of other organisations or persons the report is signed by a person of the appropriate designation.

In cases of doubt it may be necessary to refer to the manager of the Boat Safety Scheme.

### **Satisfactory Condition**

**The indications of satisfactory condition to look for in the report are as follows:**

- the examination was carried out in two stages;
- the report applies to the boat in question;
- date of examination(s); and,
- terminology.

## **Two-Stage Examination**

**The boiler must first be examined cold before it is examined under steam at normal working pressure.**

The two examinations may have been done on the same date or they may have been done on separate dates, and they may be reported on a single form or on two - one for each examination.

It is essential to establish that both examinations have been carried out.

## **Name Of Boat**

**The name of the boat in question must appear on the report.**

Note that some boilers are inspected out of the boat and the boat name is sometimes omitted by the boiler tester.

## **Date Of Examination**

**Reports are only valid for 14 months following the date of the latest examination. The only exception is where the report states a 'run-out' date in which case it is valid up to that date.**

Where the examination has been done in two parts the examinations must not be separated by too long a period. There is no maximum, but it is recommended that the examinations are done within 3 months of each other. Where the separation is longer, the Examiner must seek an explanation.

## **Terminology**

**The report must be carefully checked for words or statements such as:**

- satisfactory/unsatisfactory;
- in order/not in order;
- repairs required.

### **Electrical systems**

#### **1 – Essential material needed by BSS Examiners to be able to apply certain Part 3 Checks**

##### **1.1 Check 3.1.1 – Unsealed and open-vented batteries**

All lead-acid type batteries (wet lead-acid and valve regulated lead-acid (including Gel and Absorbent Glass Mat batteries) must be considered as being ‘unsealed or open-vented’, unless the boat owner is able to provide documentary evidence that they are ‘sealed’ in the context of hydrogen and oxygen emissions (not in the context of whether they need topping up with electrolyte).

For all battery types other than lead-acid, Examiners must assume they are ‘unsealed or open-vented’ unless the boat owner is able to provide documentary evidence that they are ‘sealed’ and do not require ventilation.

##### **1.2 Check 3.5.3 – DC charge circuits connected directly to battery terminals or to the unswitched side (battery) side of battery isolators.**

###### **How to determine whether DC charge circuits bypass a battery isolator**

On most battery installations the battery isolator(s) will be connected in the positive side, but on a very small number of installations (mainly on older boats) the isolator(s) will be connected in the negative side. The approach Examiners should take in order to determine whether charge cables are connected directly to the batteries or to the unswitched (battery) side of the isolator(s) is slightly different depending on whether the battery isolation is in the positive or negative side of the battery.

**Appendix 3**  
Essential Information

**a. Battery isolator(s) connected in the positive side**

As shown by the drawing below (Fig 1), where the battery isolators are in the positive side, Examiners must look for cables from the charge source(s) connected to the positive battery terminals and, where they can be seen, for such cables connected to the unswitched (battery side) terminal on the battery isolator(s). For a charge circuit to be present there does not have to be a visible negative charge circuit cable e.g. to a corresponding negative battery terminal; for each positive charge circuit cable there will be a cable connected to the negative side of the system somewhere, but it may not be visible at the batteries.

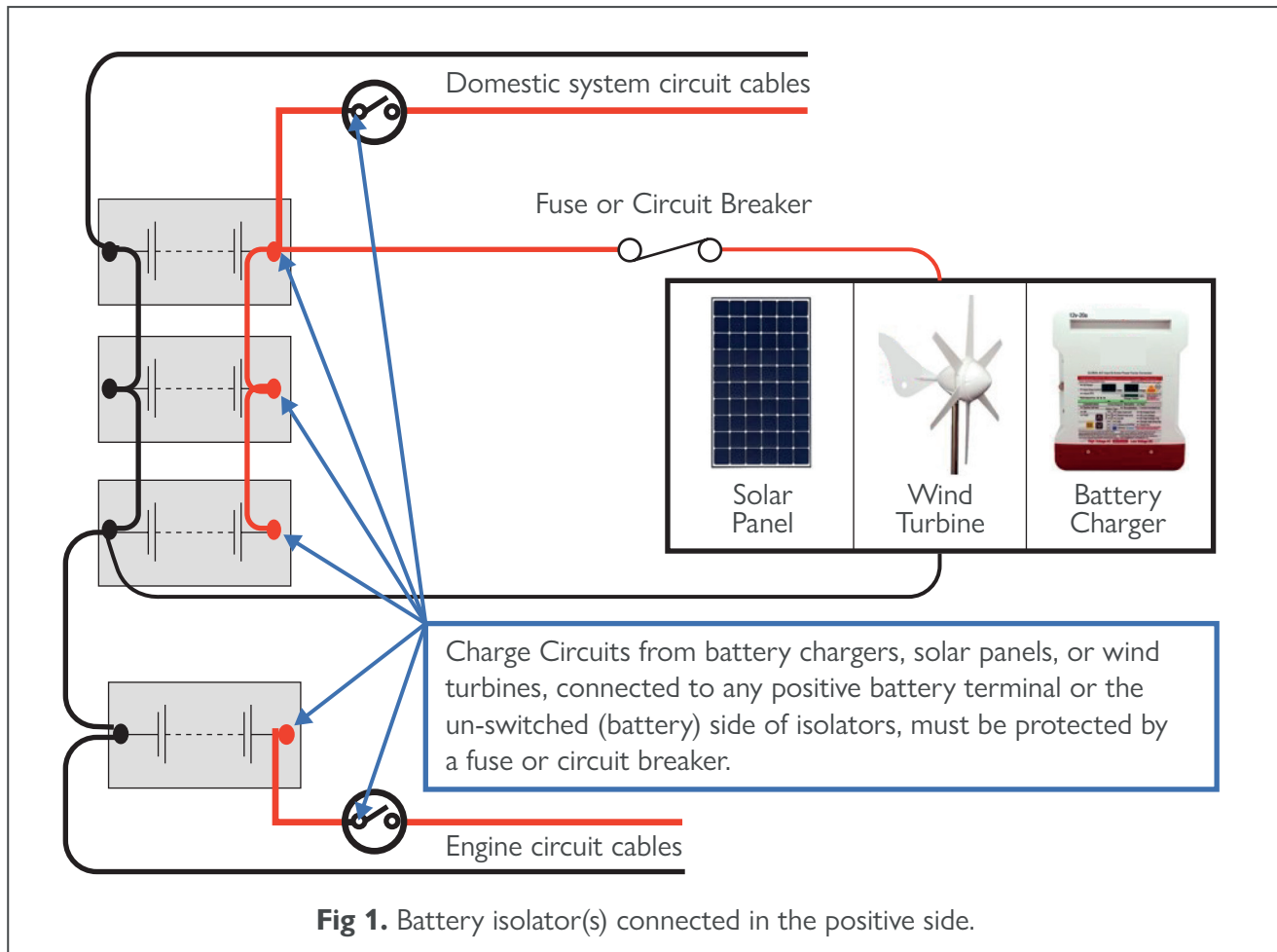

**Fig 1.** Battery isolator(s) connected in the positive side.

**b. Battery isolator(s) connected in the negative side**

It is unusual to find more than one battery isolator on a negatively isolated system. This method was common practice on older boats with simple electrical systems as it provided a single point of isolation. Although acceptable in terms of BSS compliance, negative battery isolation switching does not meet current industry installation standards.

As shown by the following drawing (Fig.2), on boats where the battery isolator(s) are in the negative side, to apply the Checking action 3.5.3 Examiners must establish whether there are charge circuit cables connected to any of the negative battery terminals. Examiners must also establish whether there are charge circuit cables connected to the unswitched connections on the battery isolator(s) where the connections can be seen.

In addition to looking for charge circuit cables connected directly to the negative battery terminals and to the unswitched (battery) side of the isolator, Examiners should look for the positive circuit cable(s) at the battery terminals. This is because it is likely that even on a negative isolated battery installation the fuse or circuit breaker in a charge circuit will be in the positive cable.

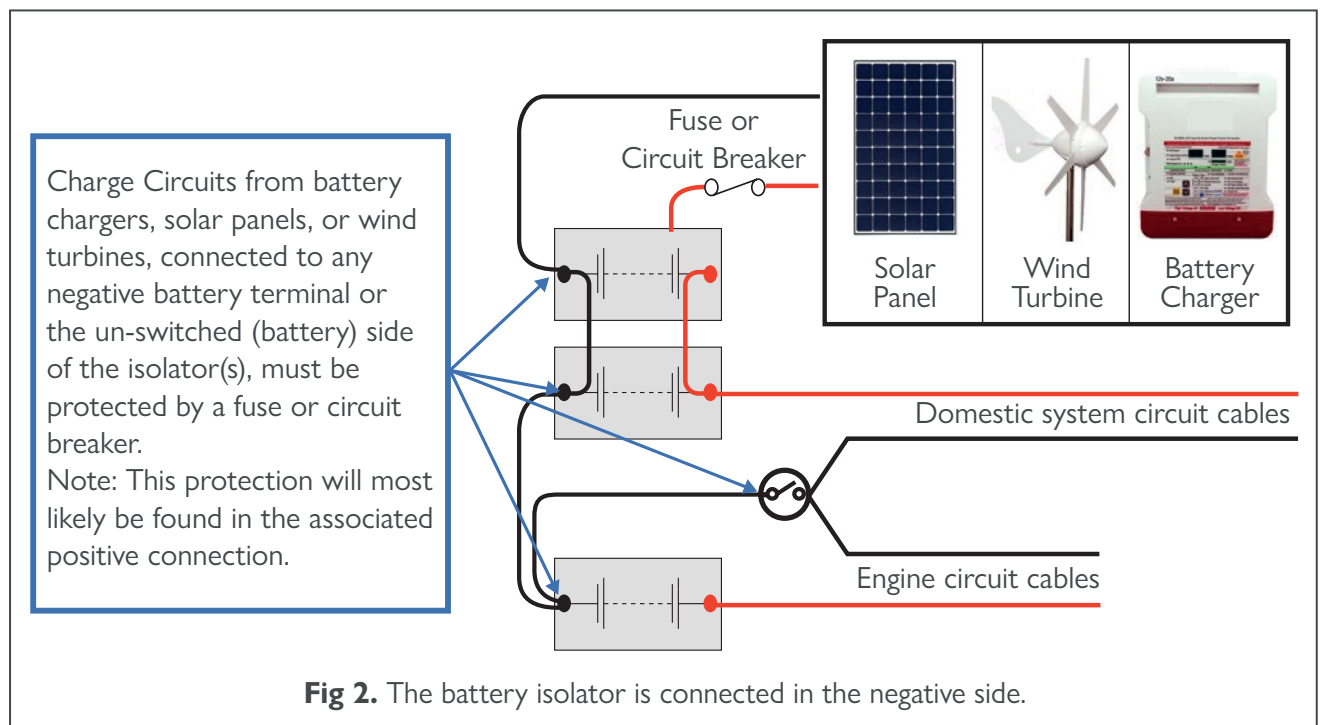

**Appendix 3**  
Essential Information

**1.3 Check 3.6.2 – DC load circuits connected directly to battery terminals or to the unswitched side (battery) side of battery isolators.**

**How to determine whether DC load circuits bypass a battery isolator**

On most battery installations the battery isolator(s) will be connected in the positive side, but on a very small number of installations (mainly on older boats) the isolator(s) will be connected in the negative side. The approach Examiners should take in order to determine whether load cables are connected directly to the batteries or to the unswitched (battery) side of the isolator(s) is slightly different depending on whether the battery isolation is in the positive or negative side of the battery.

**a. Battery isolator(s) connected in the positive side**

As shown by the drawing below (Fig 3), where the battery isolators are in the positive side, Examiners must look for load circuit cables connected to the positive battery terminals and, where they can be seen, for such cables connected to the unswitched (battery side) terminal on the battery isolator(s). For a load circuit to be present there does not have to be a visible negative load circuit cable e.g. to a corresponding negative battery terminal; for each positive load circuit cable there will be a cable connected to the negative side of the system somewhere but it may not be visible at the batteries.

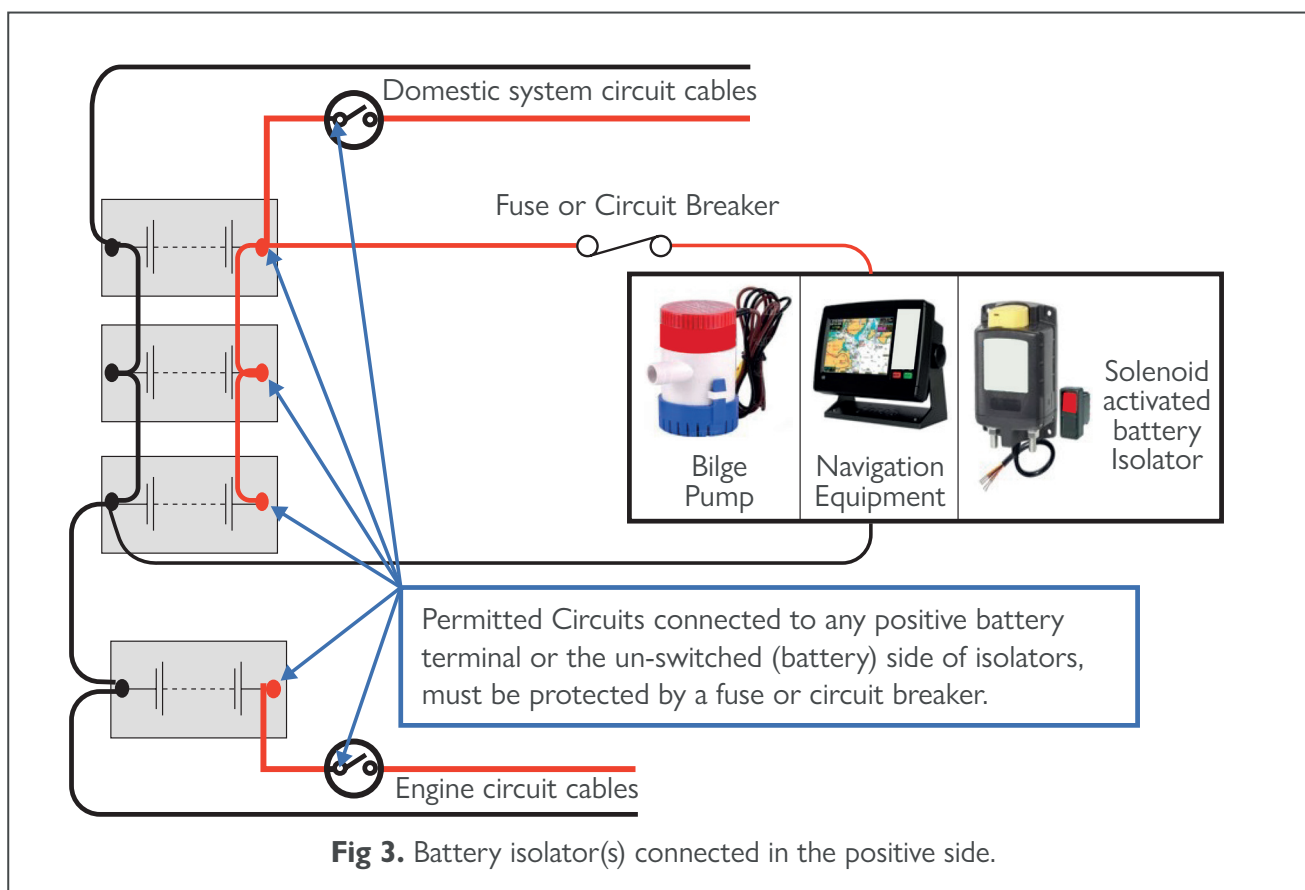

**b. Battery isolator(s) connected in the negative side**

It is unusual to find more than one battery isolator on a negatively isolated system. This method was common practice on older boats with simple electrical systems as it provided a single point of isolation. Although acceptable in terms of BSS compliance, negative battery isolation switching does not meet current industry installation standards.

As shown by the following drawing (Fig 4), on boats where the battery isolator(s) are in the negative side, to apply the Checking action 3.6.2 Examiners must establish whether there are load circuit cables connected to any of the negative battery terminals. Examiners must also establish whether there are load circuit cables connected to the unswitched connections on the battery isolator(s) where the connections can be seen.

In addition to looking for load circuit cables connected directly to the negative battery terminals and to the unswitched (battery) side of the isolator, Examiners should look for the positive circuit cable(s) at the battery terminals. This is because it is likely that even on a negative isolated battery installation the fuse or circuit breaker in a load circuit will be in the positive cable.

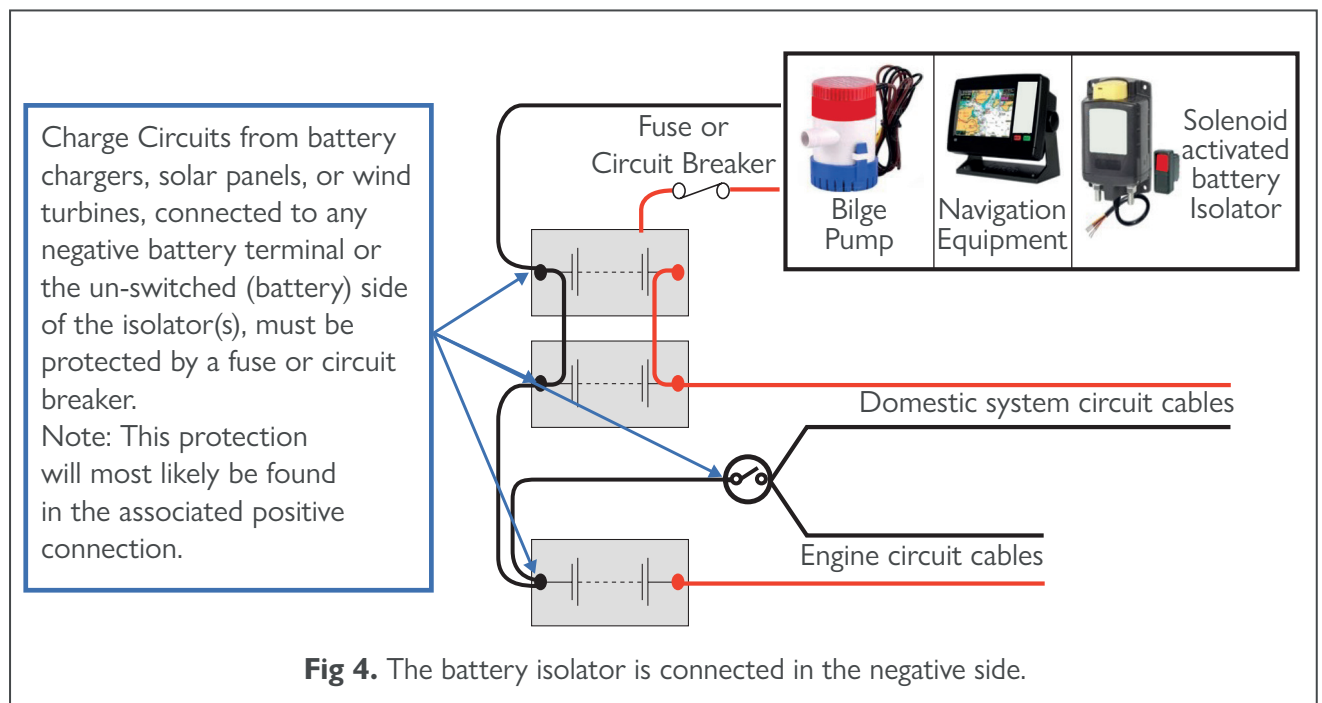

## 2 – Additional information to support BSS Examiners’ understanding of the BSS Requirements

### 2.1 General supporting information on the following concepts and fundamental knowledge can be found within the BSS Electrical Core Training Handbook:

- Rules and Regulations relevant to electricity on boats;
- Electrical health and safety guidance;
- Basics of electricity;
- Battery types, battery capacity and battery bank;
- Alternating current (AC) power sources on boats;
- Cables and cable connections (including insulation and sheathing);
- Battery isolators (types of);
- Circuit protection for DC systems (types of);
- Battery charging systems (types of);
- Circuit protection of AC systems (types of);
- Multiple AC power sources;
- Reverse polarity on AC systems;
- Earthing and bonding on AC systems;
- Galvanic corrosion;
- Electric and hybrid propulsion systems.

### 2.2 Battery space ventilation

At Check 3.1.1 all ‘unsealed or open-vented’ batteries must be stored within a ventilated space, and there must be a ventilation pathway from all battery storage locations to outside of the hull or superstructure. For BSS compliance there is no minimum free air area (in mm<sup>2</sup>) but the Guidance for owners at Check 3.1.1 recommends a minimum ventilation area (in mm<sup>2</sup>) = number of cells x capacity in Ah x 1.935. The following table provides a ready reckoner as to what this calculation may mean in practice.

Battery Capacity (Ah)	Number of 2 volt CELLS	Recommended minimum Area (mm <sup>2</sup> )	Guide - area equates to the no. of 25mm dia. holes (490mm <sup>2</sup> )
<b>6v battery</b>			
105	3	609	2
110	3	639	2
160	3	929	2
<b>12v battery</b>			
63	6	731	2
105	6	1219	3
110	6	1278	3
160	6	1857	4

Venting kits are available for some battery types. This may consist of a tube (or tubes) attached to the battery vent(s) or filler cap(s) and routed to the exterior of the vessel.

NOTE: not to be confused with self “topping-up” kits available for flooded batteries.



### 2.3 Separation between battery tops and uninsulated metallic petrol or LPG system components

At Check 3.1.4 metallic petrol or LPG system components within 300mm above battery tops must be insulated (e.g. by the presence of a conduit, shield or enclosure made of insulating material). The following drawing provides added clarity regarding the 300mm separation for metallic components that are not insulated.

Note: The area does not extend below the top of the battery.

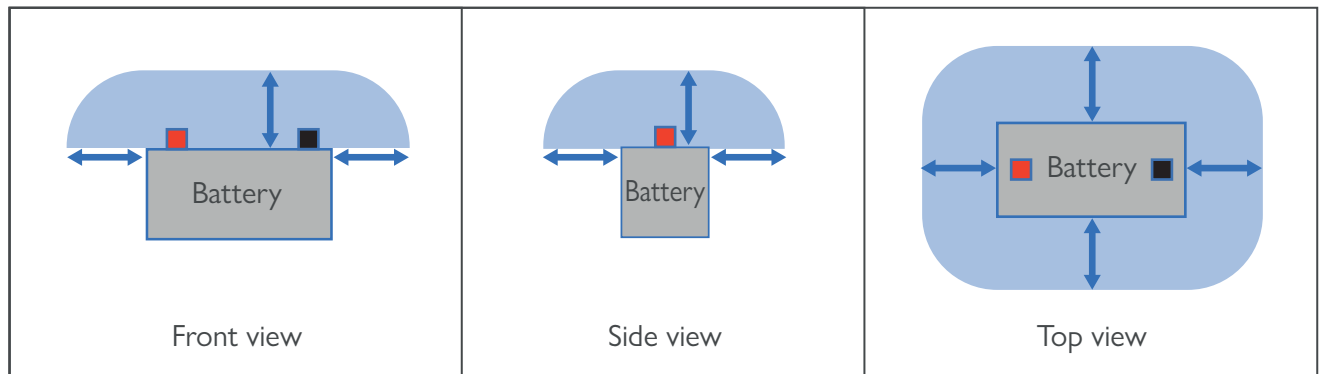

### 2.4 Scope of the BSS cable Checks at Sections 3.2 – 3.4

The cable Checks at Sections 3.2 – 3.4 apply to all cables that form part of the boat's DC and AC permanently installed electrical systems. The Requirements do not apply to:

- Electrical cables (or flexes) attached to portable electrical equipment, such as such as the 230v cable to a microwave oven, even if the equipment is plugged into the boat's electrical system at the time of the Examination;
- Petrol engine spark plug leads (these are covered separately at Check 3.3.3);
- Data and other signal cables (such as CAT 5/6 data cables and co-axial aerial cables);
- Uninsulated 'bonding' straps linking across drive couplings or between anodes.



### **Electric propulsion systems**

**Appendix 4 is currently intentionally blank. Supporting information on recognising electric and hybrid propulsion systems can be found in the BSS Core Electrical Knowledge Handbook.**



**Outboard and portable combustion engines, portable fuel systems and spare fuel****1 – Essential material needed by BSS Examiners to be able to apply certain Part 5 Checks****1.1 Kerosene, Paraffin and Petroil**

The BSS Requirements apply to kerosene and paraffin installations in the same way they do for diesel installations. Therefore, during BSS Examinations Examiners must apply the Checks to kerosene or paraffin installations as if they were diesel installations.

The BSS Requirements apply to petroil engines in the same way they do for petrol engines. Therefore, during BSS Examinations Examiners must apply the Checks to petroil engines as if they were petrol engines. Information on the nature of liquid fuels can be found in ECP Appendix 2.

**1.2 Portable fuel systems – suitable proprietary manufacture**

All portable fuel system components must be of 'suitable proprietary manufacture' (ECP Glossary term). To be of suitable proprietary manufacture components must, on the face of it, have been manufactured for purpose for which they are being used. Components will therefore have been manufactured to recognised standards and will have been performance tested by the manufacturer.

**Indicators of suitable proprietary manufacture - portable fuel tanks**

- Tanks must be designed to store the fuel in use. Tanks may be marked 'Petrol', 'Gasoline, or 'Diesel', or carry a suitable symbol, but this is not a Requirement provided they are recognisable as being suitable for the fuel in use.
- For BSS compliance portable fuel tanks must have a maximum marked capacity of 30lt. 27lt is the maximum capacity set within the international standard ISO 13591 Small craft – Portable fuel systems for outboard motors. However, the maximum capacity for portable fuel tanks in America and other countries outside of Europe is 30lt, and as many such tanks are used in the UK the BSS adopts the slightly higher 30lt capacity. Restricting the capacity ensures that the corresponding weight is reasonable for one person to carry safely.
- Tanks must be fitted with a carrying handle, configured so that they can be gripped with one hand. This is to help ensure tanks can be carried safely by minimising the risk of them being accidentally dropped.

**Indicators of suitable proprietary manufacture – fuel hose assemblies**

- To ensure the tank can be disconnected quickly and safely from the remainder of the fuel system and/or the engine, there should be at least one quick-release connector within the system. Such connectors may be at the tank, or further along the fuel supply line (e.g. at the engine connection). Where the quick-release connector is not at the tank a length of hose will often be permanently connected to the tank. Quick-release connectors should incorporate spring-loaded valves in both sections to ensure fuel cannot escape when they are disconnected.
- Hose assemblies should be considered as being of suitable proprietary manufacture unless one or more components are obviously unsuitable. Hoses do not have to be marked. Examples of obviously unsuitable components include:
  - o Clear, or translucent hose;
  - o Garden-type water hose;
  - o quick-release connections that do not automatically seal.
- Portable fuel system components do not have to originate from one manufacturer or supplier. For example, if a hose assembly's priming bulb is damaged it is acceptable to replace the bulb without replacing the hose.

### **1.3 Portable fuel systems and spare fuel containers – damage or deterioration**

'Damage or deterioration' (ECP Glossary term) is that materially affecting, or likely to affect, the integrity, efficiency, or operation of an item or device. The following are indicators of damage or deterioration:

#### **Indicators of damage or deterioration – metal fuel tanks and containers**

- Significant surface corrosion (rust) and/or any form of pitting or holes in the metal;
- Dents or gouges in the metal;
- Missing components, including carrying handles.

#### **Indicators of damage or deterioration - plastic fuel tanks and containers**

- Chafing, irregular indentations or punctures;
- Signs of corrosion attack (such as softening or environmental stress cracking);  
Softening indicates corrosive attack by the fuel causing the fuel to permeate the plastic or tank gasket material. The physical properties of the material will progressively degrade and may ultimately lead to tank failure or fuel leaks. The presence of softening may indicate that the tank is not being used in accordance with its intended purpose.

Environmental stress cracking may develop should the tank be subject to tension or bending stress beyond its design tolerance and over prolonged periods. Environmental stress cracks may cause fuel leaks.

Any form of damage or deterioration on plastic tanks and containers must be considered unsafe, and if identified the tank or container should be removed from the boat.

#### **Indicators of damage or deterioration – hoses assemblies (including priming bulbs)**





- Chafing or cuts;
- Stress cracking;
- Hardening or brittleness;
- Significant rust on metal securing clip/clamp arrangements;
- Loose clip/clamp arrangements.

# Outboard and portable combustion engines, portable fuel systems and spare fuel

## 2 – Additional information to support BSS Examiners’ understanding of the BSS Requirements

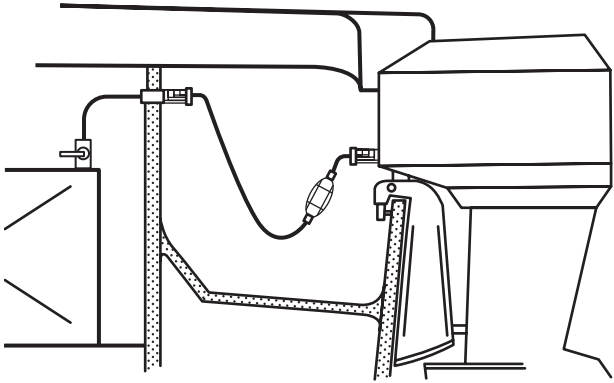
### 2.1 Permanently installed fuel systems supplying outboard engines.

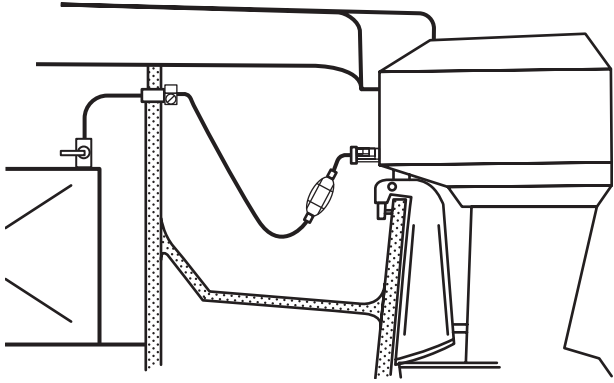
It is not uncommon for outboard engines to be supplied with fuel from permanently installed fuel tanks. In such cases the fuel system and outboard engine must be examined against the relevant Checks at ECP Part 2 and Part 5. At Check 2.10.2 and Check 5.1.1 it is recognised that outboard engine fuel hose and its connections located where any spilt fuel would drain overboard (e.g. within an outboard well) may be different to that normally specified for permanently installed hose and connections. The Figures below show the three most likely arrangements for fuel hoses and their connections running across outboard wells where there is a permanently installed tank.

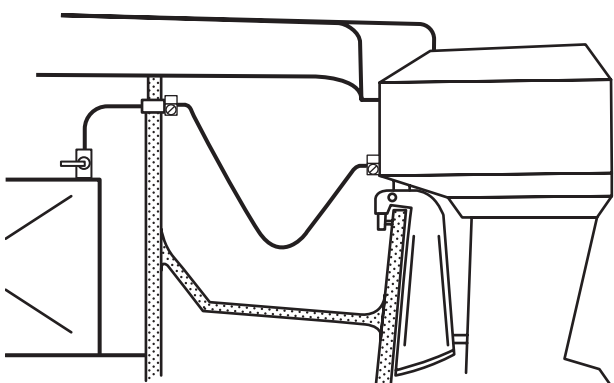
<p><b>Fig 1. Quick-release connections at the bulkhead and outboard engine</b></p> <p>In such arrangements the hose may be an unmarked proprietary portable fuel hose, but could also be to type B1 or B2 of ISO 8469, or to ISO 7840. </p> <p>A priming bulb may be fitted.</p> <p>The Checks at Part 5, section 5.2 apply to the hose and both connections.</p>	
<p><b>Fig 2. Permanent connection at the bulkhead and quick-release at the outboard engine</b></p> <p>In such arrangements the hose may be an unmarked proprietary portable fuel hose, but could also be to type B1 or B2 of ISO 8469, or to ISO 7840. </p> <p>A priming bulb may be fitted.</p> <p>The Checks at Part 5, section 5.2 apply to the hose and the outboard connection, and the Checks at Part 2, section 11 apply to the permanent connection at the bulkhead.</p>	
<p><b>Fig 3. Permanent connections at the bulkhead and outboard engine</b></p> <p>In such arrangements the hose may be to type B1 or B2 of ISO 8469, or to ISO 7840. </p> <p>A priming bulb may be fitted.</p> <p>The Checks at Part 2, sections 10 and 11 apply to the hose and both connections.</p>	

## **2.2 Portable fuel systems, and spare fuel containers**

Portable fuel systems must enable the tank to be disconnected safely from the fuel line and/or the engine without the use of tools, and permit the tank to be conveniently and safely carried ashore for refilling off the boat.

In most cases there will be a single portable fuel tank connected to the engine with a single fuel line. However, it is possible that Examiners will come across portable fuel systems with two portable tanks connected into the fuel line to the engine. In such cases it must be possible to disconnect each tank from the fuel line without the potential for leaking fuel (e.g. through the use of quick-release connectors at the tanks).

Spare portable fuel tanks are any portable fuel tanks not connected to the engine by a fuel line at the time of an Examination.

Spare fuel containers are all such containers that are not portable fuel tanks.

At the time of a BSS Examination, portable petrol tanks and spare petrol containers must be examined against relevant Requirements whether or not they contain liquid petrol (e.g. even if they only contain petrol vapours).

## **2.3 Portable fuel tanks – securing and labelling**

There is no BSS Requirement for portable fuel tanks to be secured (whether in use or spare).

Although not a BSS Requirement providing they can be otherwise recognised as being suitable for the fuel in use, Examiners should encourage boat owners to mark portable fuel tanks with 'Petrol', 'Diesel', etc to ensure the correct fuel is used.

Also, although not a BSS Requirement, Examiners should encourage boat owners to affix a 'Refill ashore' label to all portable fuel tanks.

## **2.4 The Petroleum (Consolidation) Regulations 2014**

The Petroleum (Consolidation) Regulations 2014 regulate the stowage of spare petrol in the UK, including on boats. The Regulations stipulate that the amount of spare petrol carried on a boat is limited to a maximum of 30 litres.

Spare petrol is made up of spare petrol containers and any spare portable petrol tank i.e. one that is not connected to the engine.

The Regulations are intended to mitigate:

- a) the risk of storing large quantities of petrol on board; and,
- b) the hazard associated with storing and/or decanting fuel from inappropriate containers.

The Regulations apply to all boat owners and it is the responsibility of individual boat owners to ensure compliance. The Health & Safety Executive (HSE) enforce the Regulations and have agreed the BSS approach to petrol stowage as set out at Checks 5.3.1 – 4.

It could be interpreted that BSS have a Requirement at 5.3.3 (2nd bullet-point) that is, on the face of it, in excess of the permitted maximum volume stored by up to 10 litres; but the BSS are clear that it remains the boat owner's responsibility to stay within the legal maximum of 30 litres of spare petrol by not filling the spare containers or tank to capacity. HSE accepts that it is not the role of BSS Examiners to accurately measure the capacity of spare petrol onboard and neither is it the role of BSS Examiners to enforce Petrol (Consolidation) Regulations.

The approach is intended to allow the potentially critically needed allowance for a spare portable petrol tank, plus up to two small spare petrol containers for use for example with a generator and/or auxiliary outboard, etc. This approach is necessary to address concerns about the increased decanting risk if a spare portable tank could not be accommodated on board.



Prior to the introduction of the 2014 Regulations, acceptable spare petrol containers included those made to the Petroleum-Spirit (Motor Vehicles, etc.) Regulations 1929 and the Petroleum-Spirit (Plastic Containers) Regulations 1982. This legislation was repealed by the 2014 Regulations and now the BSS refers only to the marking requirements for such containers which have remained very similar over time. The type of portable petrol containers is also regulated by the Petroleum (Consolidation) Regulations. According to the Regulations a portable petrol container must:

- a) have a nominal capacity –
  - i) no greater than 10 litres if made of plastic; and
  - ii) no greater than 20 litres if made of metal;
- b) have a total capacity between 10% and 15% more than the nominal capacity [to allow for expansion of fuel as the temperature increases to the ambient level];
- c) be made of either metal or plastic that is suitable and safe for the purpose and will not significantly degrade due to exposure to petrol or naturally occurring ultra-violet radiation;
- d) be designed and constructed so that –
  - i) it is reasonably robust and not liable to break under the normal conditions of use;
  - ii) the escape of liquid or vapour is prevented;
  - iii) petrol can be poured safely from it; and
  - iv) it is not unsteady when placed on a flat surface;
- e) be marked or labelled in a legible and indelible form with –
  - i) the words “PETROL” and “HIGHLY FLAMMABLE”;
  - ii) an appropriate hazard warning sign;
  - iii) the nominal capacity in litres; and
  - iv) the manufacturer’s name and the date and month of manufacture.

Note that:

- a) “nominal capacity” means the maximum volume of liquid that the container is intended to hold at 20°C;
- b) “total capacity” means the maximum volume of liquid that the container would hold if filled to the brim.
- c) The Regulations include ‘type testing’ requirements for plastic petrol containers, including
  - i) Impact test – drop test;
  - ii) Leakage test – no leakage when subjected to internal pressure;
  - iii) Strength test – remains intact with internal pressure at up to 1.6bar;
  - iv) Permeability test;
  - v) Stress cracking test.
- d) Examples of suitable warning signs include: -

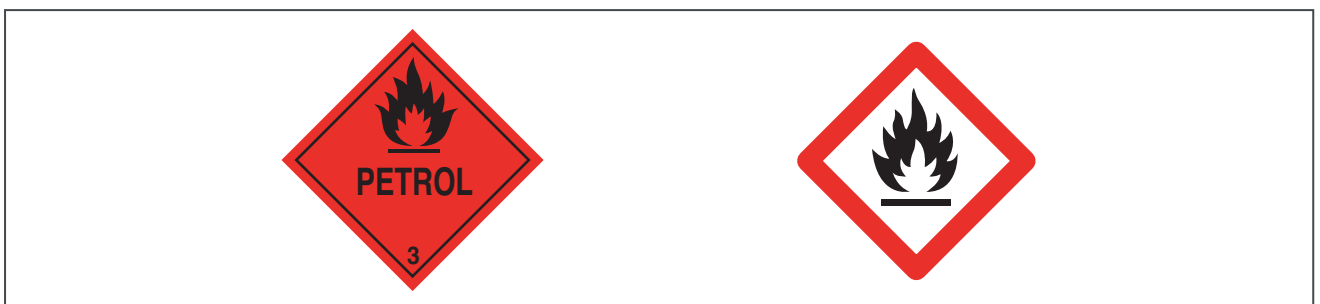

- e) There are no restrictions on the colour for plastic or metal containers, but general custom and practice is that green is used for petrol.

## Appendix 5

### Additional Information

The Petroleum (Consolidation) Regulations specifications above that are grey-highlighted have been adopted as BSS Requirements. The remaining specifications have not been adopted as BSS Requirements, but boat owners should be aware of all the specifications to ensure they are only using petrol tanks and containers that are compliant with the Regulations.

### 2.5 Outboard engine mounting systems

Outboard engines are usually secured to transoms in one of two ways: quick-release clamps; bolts through the transom. Clamps are usually used on smaller engines with lower h.p. ratings where the engine is removed from the boat for servicing. Bolting tends to be used on larger engines which often remain fixed to the transom for servicing. Some engines may utilize both securing arrangements.

On quick-release arrangements the clamps must be tight. On bolted arrangements the bolts must be tight, and there must be no indications of missing bolts. On both arrangements there must be no signs of damage or deterioration on the mounting bracket or securing arrangements.

Fig 4. shows a mounting bracket with both quick-release clamps, and bolts fitted.

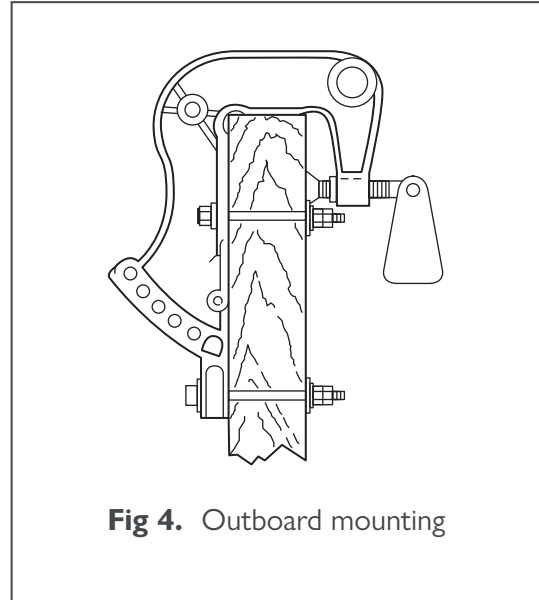

**Fig 4.** Outboard mounting

**Outboard and portable combustion engines, portable fuel systems and spare fuel**  
**1 – Essential material needed by BSS Examiners to be able to apply certain ECP Part 6 Checks**

**1.1 Portable fire extinguishers – essential material - accredited third-party certification marks**

To be considered as ‘suitable’ at Check 6.1.1 portable fire extinguishers must be marked with at least one of the following accredited third-party certification marks –

 <p><b>AFNOR ‘NF’ mark</b></p>	 <p><b>Apragaz Belcert</b></p>	 <p><b>BSI ‘Kitemark’</b></p>
 <p><b>British Approvals for Fire Equipment</b></p>	 <p><b>British Approvals for Fire Equipment</b></p>	 <p><b>Marine Equipment Directive ‘ship’s wheel’</b></p>
 <p><b>Loss Prevention Certification Board</b></p>	 <p><b>Loss Prevention Certification Board</b></p>	 <p><b>Société Générale De Surveillance</b></p>

A CE or UKCA mark on a portable fire extinguisher is not an accredited third-party certification mark. The CE or UKCA mark relates to the European Pressure Equipment Directive (Regulations in the UK) (PED). Conformity with the PED does not give any assurance of manufacture or performance testing to a portable fire extinguisher manufacturing standard.

Examiners may accept Firemaster 1000PR B/C [Brass/Chrome] models as being accredited third-party certificated even though they may not carry one of the above marks.

This is because Firemaster have provided the BSS Office with documentary evidence of appropriate certification.



## **1.2 Emergency escape and carbon monoxide alarms – essential material – understanding the ECP Glossary term ‘accommodation space’**

To be able to apply the Checking actions at Checks 6.3.1 and 6.4.2 in a robust and consistent manner Examiners must be able to recognise accommodation spaces.

ECP Glossary term – Accommodation space –

“Space surrounded by permanent boat structure in which there is provision for any of the following activities: sleeping, cooking, eating, washing/toilet, navigation, steering. Spaces intended exclusively for storage, open cockpits with or without canvas enclosures and engine rooms are not included.”

Therefore, each individual space within a boat completely surrounded by permanent boat structure, and where there is provision for sleeping, cooking, eating, washing/toilet, navigation, or steering, is an individual accommodation space.

In the context of accommodation spaces, movable flexible screens/curtains/hoods are not permanent boat structures.

Wheelhouses – wheelhouses completely enclosed by permanent boat structure are accommodation spaces, but wheelhouses with canvas-type screens/curtains, and cockpits with canvas-type hoods are not accommodation spaces. As such movable flexible screens/curtains/hoods are not permanent boat structure.

Individual passageways – individual passageways completely surrounded by boat structure are not accommodation spaces unless there is provision for sleeping, cooking, eating, washing/toilet, navigation, or steering within the passageway.

Engine rooms – engine rooms are not accommodation spaces however they are configured (e.g. even walk-through engine rooms are not accommodation spaces in the context of the BSS Requirements).

## **1.3 Carbon monoxide alarms - essential material - measuring the distance between a carbon monoxide alarm and any door that links accommodation spaces**

The second Requirement at Check 6.4.1 specifies that on boats with two or more accommodation spaces a carbon monoxide (CO) alarm must be located within 10m of any door that links the accommodation spaces.

Where there are a number of accommodation spaces (e.g. separate cabins) the sound of an alarm will be deadened by the separating boat structures including closed cabin doors.

By requiring an alarm to be located within 10m of each door that links accommodation spaces there is an assurance that wherever someone is located within the interior of a boat they are likely to be able to hear an activated alarm.

In the context of Check 6.4.1, ‘links’ means that the door can be used to gain access to another accommodation space, even though the two accommodation spaces may not be immediately adjacent, or directly connected, to each other.

The following two diagrams help explain the distance measurement Requirements for different accommodation space configurations.

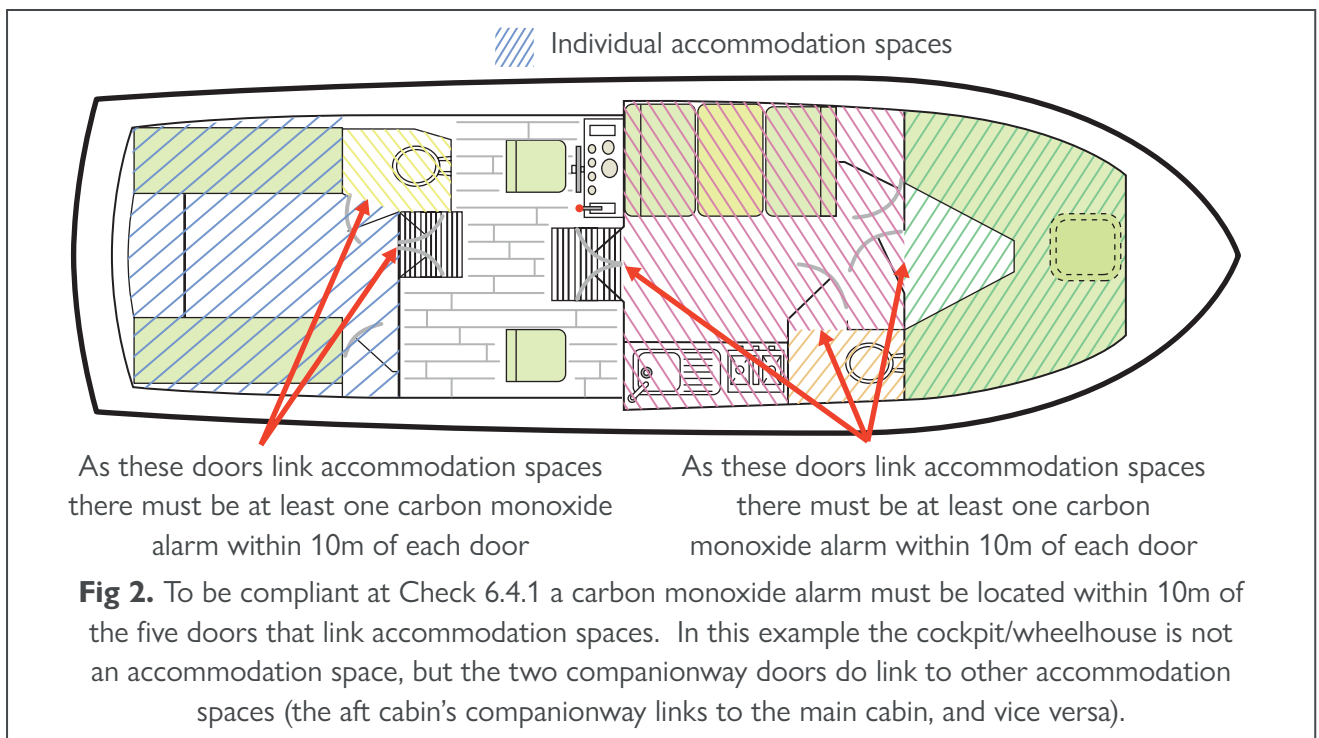
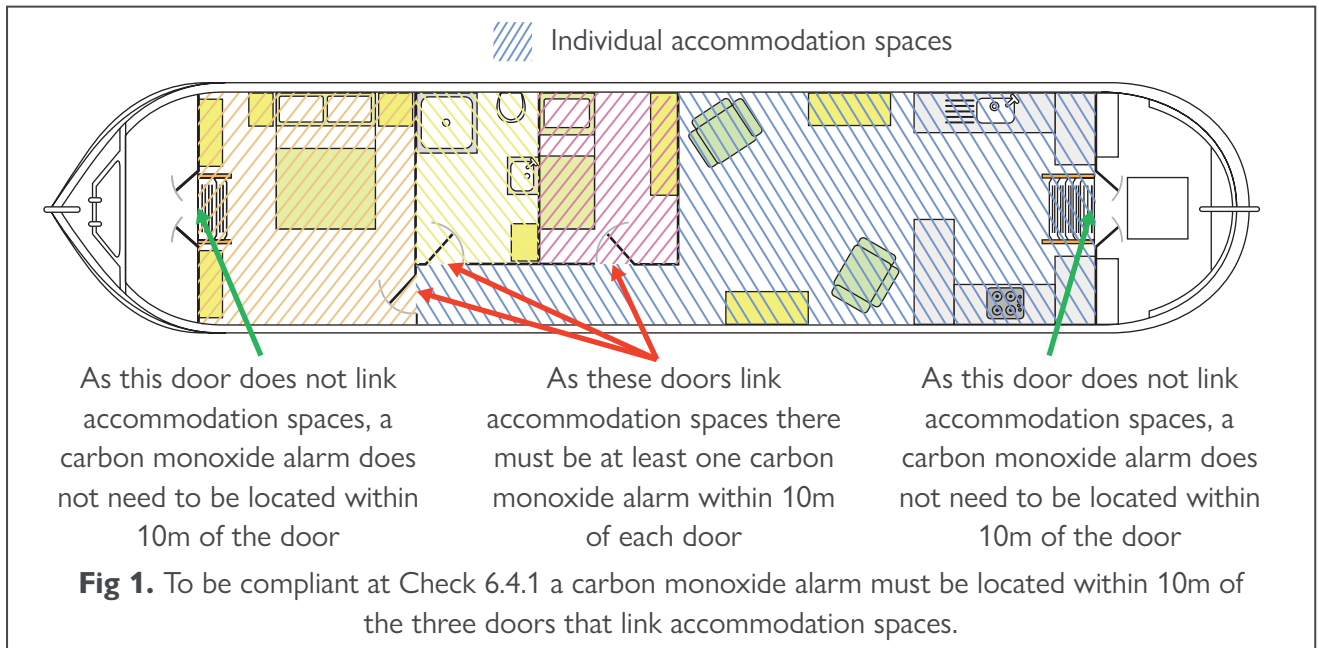

### 1.4 Carbon monoxide alarms – essential material – accredited third-party certification marks

The principles behind the certification of CO alarms are the same as those for portable fire extinguishers.

In the UK the main accredited third-party certification marks likely to be found on CO alarms are those of the British Standards Institute (BSI) and the Loss Prevention Certification Board (LPCB).

However, UL International (UK) Ltd are also recognised as an accredited certification body in respect of the certification of CO alarms to BS EN 50291, and as such their mark may also be found on suitable CO alarms.

Other certification body marks may be acceptable, but Examiners should contact the BSS Office for confirmation of acceptability if other marks are found.



**Appendix 6**  
Essential Information

Because the following companies only make CO alarms to BS EN 50291, and because all their alarms are certified by an accredited third-party certification body, Examiners are not required to establish the accredited third-party certification mark on CO alarms made by the following companies:

BRK	Fire Angel	Honeywell
Dicon	Fire Hawk	Kidde
Ei Electronics	First Alert	

A CE mark on a CO alarm is not an accredited third-party certification mark. The CE mark relates to the Electromagnetic Compatibility (EMC) Directive. Conformity with the EMC Directive does not give any assurance of manufacturing quality or performance testing to a CO alarm manufacturing standard.

## 2 – Additional information to support BSS Examiners’ understanding of the BSS Requirements

### 2.1 Portable fire extinguishers – classification of fires

Class **A** fire = fires involving solid materials, usually of an organic nature, in which combustion normally takes place with the formation of glowing embers (such as paper, wood and similar materials);

Class **B** fire = fires involving liquids (such as petrol, paraffin or alcohol) or liquefiable solids (such as rubber, wax or tallow);

Class **C** fire = fires involving gases (such as propane and butane);

Class **D** fire = fires involving metals;

Class **F** fire = fires involving cooking media (vegetable or animal oils and fats) in cooking appliances.

For protection from a Class C and D fire risk, professional specialist advice is needed.

Fires involving electrical equipment are unclassified, since electricity is a source of heat. Although fires may start due to an electrical fault, they will often spread to involve materials from other classes, such as a timber bulkhead or hull side linings.

### 2.2 Portable Fire extinguishers – types, and how they work to extinguish fires

Portable fire extinguishers are designed to be carried to a fire and operated by hand.

Fuel, heat and oxygen must be present in order to achieve combustion. When all three factors are present in the correct proportions, combustion will occur.

There are seven main types of extinguishing medium; water, foam, powder, carbon dioxide, wet chemical, clean agent and water mist. Each is suitable for use on different types (or classes) of fire and has various benefits and limitations. The following table contains general guidance as to how the extinguisher mediums work to remove heat and/or oxygen to extinguish a fire.

Since the introduction of the manufacturing standard EN 3, portable fire extinguisher bodies are usually coloured predominantly red, although polished metal types are available. All extinguishers manufactured to EN 3 should carry a coloured zone of 3-10% of the external area to indicate the type of extinguishing medium used. The fire ratings are also usually found marked within the coloured zone or immediately adjacent to it.

Extinguishing medium	Zone colour coding	Class of fire	Extinguishing method
<b>Water</b>	Red	A	Cooling
<b>Foam</b>	Pale cream	A/B	Smothering
<b>Powder</b>	Blue	[A]/B/C and electrical	Knock-down and smothering
<b>CO<sub>2</sub></b>	Black	B/C and electrical	Displaces oxygen
<b>Wet chemical</b>	Canary yellow	A/B/F	Smothering and cooling
<b>Clean agent</b>	Green	A/B	Changed chemical reaction
<b>Water mist</b>	White	A/[B]/F	Cooling and smothering

The BSS requires each portable fire extinguisher to be capable of tackling both Class A and Class B fires (the main classes of fires experienced on small craft) and so the choice is currently limited to foam, powder and a limited number of wet chemical, clean agent and water mist extinguishers.

As carbon dioxide (CO<sub>2</sub>) is an asphyxiant and CO<sub>2</sub> extinguishers have freezing capabilities, the use of a CO<sub>2</sub> extinguisher in confined spaces could lead to the personal injury of the user or other occupants. The published BSS guidance is for boat owners to be knowledgeable about safe use and take care when using CO<sub>2</sub> extinguishers in accommodation or other confined space onboard.

Halon extinguishers are the subject of an international ban, are illegal to have on board and are not to be considered as part of the specified number of portable fire extinguishers. Current advice is for owners to contact local recycling centres or specialist waste disposal companies to arrange for an environmentally-friendly disposal.



### **2.3 Portable fire extinguishers - fire ratings**

The fire rating of an extinguisher appears as a series of numbers and letters e.g. 5A/34B. The letters indicate the class of fire, and the numbers relate to the ability of the extinguisher to successfully put out a fire under test conditions. The bigger the numbers, the bigger the fire on which the extinguisher has been tested.

It is important to appreciate that 5A/34B is the minimum accepted fire rating for an individual extinguisher and that this is a small extinguisher for small fires. For example, a 5A/34B dry powder unit once deployed is likely only to last around ten seconds. The sizing is commensurate with the purpose of the BSS portable fire extinguisher Requirements, namely, to provide boat owners with the means to knock-down a small fire before it escalates, or to knock-back a fire enough to enable boat occupants to escape past it.

At Check 6.1.1 the minimum number of portable fire extinguishers may be reduced by a maximum of one 5A/34B rated extinguisher where the vessel has either no internal combustion engines, or no fuel-burning appliances. This is because internal combustion engines and fuel burning appliances are a major cause of boat fires, so if one or both of these causes of fire are not present the overall risk of a fire starting is reduced.

### **2.4 Portable fire extinguishers - manufacturing standards**

BS EN 3, Portable fire extinguishers, covers the manufacturing of portable fire extinguishers from 1kg to 12kg and 2-litres to 9-litres capacity. The standard is of more relevance to extinguisher manufacturers than the end user, but it specifies in detail the extinguisher characteristics, duration of operation, any residual charge, and the performance testing of portable fire extinguishers.

BS 5423, Specification for portable fire extinguishers, was the previous portable fire extinguisher manufacturing standard, but it was superseded by BS EN 3 and withdrawn in 1997.

### **2.5 Portable fire extinguishers - accredited third-party certification marks**

The BSS does not require portable fire extinguishers to have been manufactured to a particular standard (e.g. BS EN 3), but it does require such extinguishers to carry at least one accredited third-party certification mark.

Accredited third-party certification, sometimes known as 'type approval' schemes ensure a high level of confidence in the manufacturer's claims of adherence to manufacturing and performance standards and consistent product quality. In practice this works by accreditation bodies taking account of the performance testing reports of accredited laboratories and overseeing the manufacturing process to ensure that extinguishers are consistently manufactured to the correct standard. Extinguisher manufacturers are then licenced to display the accreditation body's mark on their extinguishers. Accredited third-party certification is employed extensively in safety critical applications.

The accreditation third-party certification bodies whose marks are shown at Appendix 6 Section 1 are themselves accredited by the relevant national accreditation body to attest the manufacture and performance testing of portable fire extinguishers to EN 3.



## Appendix 6 Additional Information

### 2.6 Portable fire extinguishers - servicing

The BSS does not require portable fire extinguishers to be serviced. However, boat owners are recommended to have portable fire extinguishers serviced in accordance with the servicing standard BS 5306 where this standard is printed on the body of the extinguisher. When an extinguisher has been serviced in accordance with BS 5306 the service technician will affix a service label to the extinguisher body which should include all the following information:

- full postal address of the servicing company;
- date of service;
- type of service – basic, extended or overhaul;
- engineer's ID;
- date of last discharge; and,
- weight.

British Approvals for Fire Equipment (BAFE) registered service technicians are recommended - BAFE is a not-for-profit organisation which promotes quality within the fire protection industry, including administering the Registered Fire Extinguisher Service Technicians Scheme.

However, 'service-free' or 'maintenance-free' portable fire extinguishers are becoming more popular. Extinguishers of this type may not be marked 'service-free' or 'maintenance-free', but they may be distinguishable by there being no reference to BS 5306 printed on them. For extinguishers of this type it is for the boat owner to inspect them regularly for operational serviceability as specified by the manufacturer. If boat owners are in doubt as to whether a portable fire extinguisher is 'service-free' or 'maintenance-free' they are recommended to contact the manufacturer for further information.

### 2.7 Portable fire extinguishers – obsolete or excessive numbers of extinguishers

Portable fire extinguishers in greater numbers than required at Check 6.1.1 may be found on board. This is acceptable as the BSS Requirements are minimum safety, rather than absolute, specifications.

The published BSS guidance for boat owners is that where portable extinguishers are kept on board in additional numbers to the minimum BSS Requirements, these will not be subject to Checks 6.1.1.

6.1.3. Published BSS guidance is for boat owners to remove from the boat any additional portable fire extinguishers not marked with an accredited third-party certification mark and not in good condition, as these may not work or work effectively and safely if called upon. Alternatively, owners are recommended to replace such units with compliant extinguishers.

Current advice is for owners to contact local recycling centres or specialist waste disposal companies to dispose of unwanted portable fire extinguishers.

### 2.8 Fixed fire extinguishing systems

The BSS Requirements do not include minimum specifications for fixed fire extinguishing systems such as those installed in engine spaces. There are a number of reasons for this, including that fixed systems cannot be certified by accredited third-party certification bodies, and that ensuring fixed systems are appropriate for the engine/s and engine space is relatively complicated.

Instead, the approach taken is to promote that engine space fuel and electrical components meet BSS Requirements so as to help minimise the chance of an engine space fire, and also that fire-resistant fuel components mitigate the risk in the event of a fire and allow added time for craft occupants to escape.

The BSS website does include an encouragement for boats owners to consider having fixed automatic fire extinguishing systems in engine spaces. Because such products cannot be certified by an accredited certification body, assurances may be gained by choosing items approved by a relevant marine body such as the Maritime and Coastguard Agency. Competent installers should be used to help select the right size and type of a fire extinguishing system for the engine space and advice regarding any required onward service costs.

Fig 3. Example service label



## 2.9 Fire blankets

**BS EN 1869, Fire blankets**, covers the manufacturing of fire blankets. **BS 6575, Specification for fire blankets**, was the previous fire blanket manufacturing standard, but it was superseded by BS EN 1869 and withdrawn in 1999.

To be of the correct specification at Check 6.2.1 fire blankets only have to be marked 'BS EN 1869' or 'BS 6575'. Fire blankets do not have to carry an accredited third-party certification mark. Note however, that fire blankets manufactured outside of the UK may not be marked 'BS EN 1869' and may just be marked 'EN 1869' or 'xx EN 1869'.

The published BSS guidance for boat owners is to replace a fire blanket after use as even the slightest imperfection can result in the blanket being completely ineffective. A fire blanket which doesn't work may actually help to spread a fire quicker, and it could instead escalate in severity.

Fire Industry Association (FIA) advice is to replace fire blankets if there is wear, contamination or damage to the fire blanket material or damage to the fire blanket hand held devices or serious damage to the container. FIA advice is to follow any replacement date instructions, or if there are none then if more than seven years from date of commissioning consider replacing the blanket.

## 2.10 Emergency escape

Requiring each accommodation space to have two means of escape means that, wherever they are located, occupants should be able to turn their back on the threat, whether it is a fire, or water caused by sinking or being hung up in a lock, and make a safe exit.

Means of escape may be main doors, proprietary hatches, opening windows or fixed windows provided with a means of breaking out.

The published BSS guidance for boat owners is not to lock exits from the outside, and not to block them with **boat equipment or personal** possessions, etc., and owners are recommended always to have two means of escape available to them in order to be able to turn their back on the threat.

As shown at Fig 4, individual cabins with one door opening into a fore-aft passageway need not have a second means of escape so long as the passageway allows escape at each end.

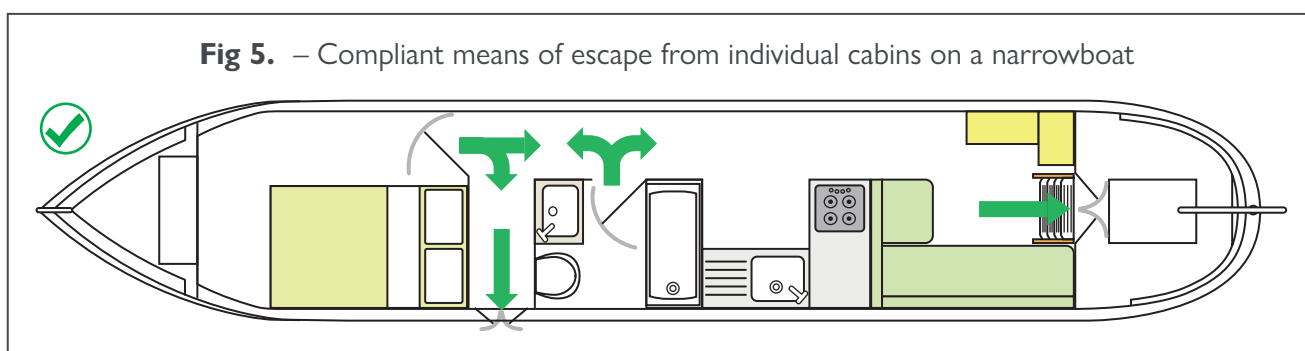
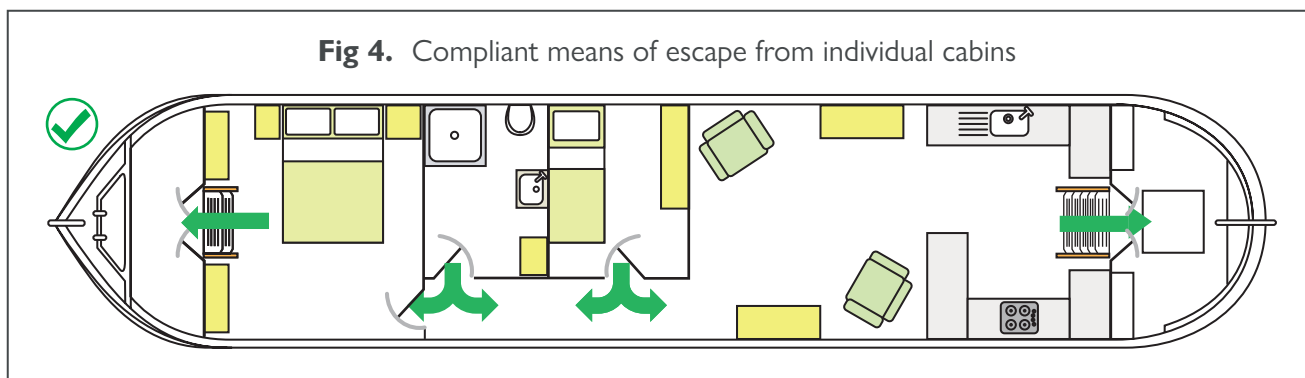

Fig 5 shows an individual cabin at the forward end of the accommodation space with compliant means of escape, but the same approach applies where there is an individual cabin aft with a solid bulkhead to the engine space. This arrangement is compliant because a person exiting the cabin can choose to go aft or turn immediately to port and exit through the side hatch.

In such cases, where a side hatch provides one of the two means of escape, published BSS guidance for boat owners is that the escape route may not be effective in certain emergency situations. For example, in a narrow lock it may not be possible to open side hatch doors.

Also, in the event of a narrowboat being hung-up in a lock, using a side hatch as a means of escape may itself place the occupants in further danger.

### **2.11 Carbon monoxide poisoning – reference material**

The CoGD/EM/BSS awareness leaflet ‘Carbon Monoxide Safety on Boats’ should be considered as authoritative and as containing crucial underpinning knowledge for boat owners.

Additional safety information and guidance is available on the BSS website at [www.boatsafetyscheme.org/co](http://www.boatsafetyscheme.org/co)

### **2.12 Carbon monoxide – the BSS Requirements**

The Requirement at Check 6.4.1 that all boats having one or more accommodation space(s) must be provided with at least one carbon monoxide (CO) alarm addresses the risk presented by carbon monoxide entering from sources outside the boat. CO entering from outside a boat can quickly build up to dangerous levels as the enclosed nature of accommodation spaces means that it may not be easily dissipated or vented.

The Check at 6.4.2 (Advisory for privately owned and managed boats) addresses the risk presented by CO emissions from solid fuel stoves. Solid fuel stoves present a specific CO risk as during normal operation they can produce 100 times more CO than LPG hob burners that are faulty. In addition, solid fuel stoves are known to be a particular threat at night when occupants are asleep (when there are relatively fewer air changes within the boat, and when a fire within a solid fuel stove is dying down). A CO alarm in the same space as the stove provides protection to craft occupants should flue gases escape from the stove into the space.

### **2.13 Carbon monoxide alarms - manufacturing standards**

Until 2010 BS EN 50291 was a single standard, but in 2010 it was divided into two parts (BS EN 50291-1 and BS EN 50291-2).

The Requirement at Check 6.4.3 is simply that carbon monoxide (CO) alarms must be certified to BS EN 50291, and therefore compliant CO alarms may have been certified to BS EN 50291, BS EN 50291-1, or BS EN 50291-2. However, as the life expectancy of a CO alarm is usually 7-10 years it is unlikely that Examiners will come across many CO alarms manufactured to the original BS EN 50291.

Although the BSS accepts CO alarms certified to BS EN 50291, BS EN 50291-1, or BS EN 50291-2, alarms to BS EN 50291-2 are best suited for boats. The ‘-2’ edition of the BS EN means that the units will have been tested to meet additional performance standards specifically relevant to boat installation - namely, shock, static orientation, dynamic orientation, and steady-state acceleration.

Therefore, although not a BSS Requirement, at the point of selection boat owners are recommended to choose ‘-2’ units. The BSS website has a list of ‘-2’ alarms recommended by the makers as suitable for use in boats [www.boatsafetyscheme.org/co](http://www.boatsafetyscheme.org/co)

CO alarms manufactured outside of the UK may not be marked ‘BS EN 50291’ and may just be marked ‘EN 50291’ or ‘xx EN 50291’

The Requirement at Check 6.4.3 states that accredited third-party certification can be to BS EN 50291 or equivalent. At this time the BSS is not aware of an equivalent standard to BS EN 50291 and so any claims of equivalence should be reported to the BSS Office.

Dual alarms (for example smoke/CO alarms) can be accepted provided the CO alarm aspect has accredited third-party certification to BS EN 50291.

### **2.14 Carbon monoxide alarms – unsuitable, or excessive numbers**

The BSS recommends that only CO alarms deemed a suitable type at Check 6.4.3 should be trusted to provide protection from CO poisoning. Any unsuitable CO alarms should be removed or replaced by the owner from the boat because they may not work, or work effectively and safely, if called upon.

CO alarms in greater numbers than required at Check 6.4.1 and/or 6.4.2 may be found on board. This is acceptable as the BSS Requirements are minimum safety, rather than absolute, specifications. The published BSS guidance for boat owners is that where CO alarms are kept on board in additional numbers to the minimum BSS Requirements these will not be subject to Checks 6.4.3 or 6.4.4.

### **2.15 Carbon monoxide alarms – location and placement**

The BSS Requirements (at Checks 6.4.1 to 6.4.4) do not address the location or placement of CO alarms, other than the Requirement at Check 6.4.3 that alarms found to be necessary at Checks 6.4.1 and/or 6.4.2 must be in open view.

Guidance for boat owners regarding the location and placement of CO alarms to provide best protection can be found with the alarm manufacturers' installation instructions. However, if these instructions are difficult to meet on the boat, then best practice pointers are published in the CoGDEM/BSS awareness leaflet 'Carbon Monoxide Safety on Boats', and on the BSS website at [www.boatsafetyscheme.org/co](http://www.boatsafetyscheme.org/co)

### **2.16 Carbon monoxide alarms – can detect hydrogen gas**

The published BSS guidance for boat owners is that CO alarms can activate when batteries gas off, especially if the boat's batteries are being over-charged. The chemical sensors in CO alarms react to hydrogen typically at around 5% of the Lower Explosive Limit.

Therefore, there is a concern that if the concentration of diluted hydrogen has reached this level at the remote location of the CO alarm, then the hydrogen concentration closer to the source of the emission is likely to be much higher, and could be approaching an explosive concentration, especially in the battery compartment itself.

Hydrogen readily forms an explosive mixture with air and the ignition energy required to ignite a flammable hydrogen/air mix is very low. Even very small sparks, such as those produced by wearing certain types of clothing, are capable of igniting hydrogen/air mixtures and causing an explosion.

Accordingly, published BSS guidance for boat owners is that should battery charging produce enough hydrogen to activate a CO alarm, it is a call to action not to be ignored by the boat owner. If any boater is confident that a CO alarm activation was not caused by the presence of CO, they should stop the battery charging, not allow any source of ignition to be operated, and should investigate any battery charging issue having first immediately opened windows, doors and awnings to disperse any hydrogen – noting that the flammable gas rises rapidly.

### Liquefied Petroleum Gas (LPG) systems

#### 1 – Essential material needed by BSS Examiners to be able to apply certain Part 7 Checks

##### 1.1 Cockpits

For the purposes of the BSS Checks, the term ‘cockpit’ should be considered to include any recessed area that is lower than the surrounding decks, such as well decks on narrowboats and aft cockpits on river cruisers.

##### 1.2 ‘Self-draining’ cockpits

Checks 7.1.1, 7.2.3, 7.2.4 and 7.2.5 refer to ‘self-draining’ cockpits.

Only a qualifying ‘self-draining’ cockpit can be considered to be in an ‘open location’. In the context of LPG cylinder stowage, the BSS has adopted the term ‘self-draining’ cockpit from the British Standard PD 54823 – Guidance for the design, commissioning and maintenance of LPG systems in small craft.

If a cockpit is ‘self-draining’ as defined below, it may be considered to be an open location (see Check 7.1.1) and therefore a cylinder located within the cockpit does not have to be within a locker. However, to prevent any gas escaping from a cylinder finding its way into the interior of a vessel, in general terms the cockpit must drain overboard and must be watertight to the interior of the vessel.

When determining compliance at Checks 7.1.1, 7.2.3, 7.2.4 and 7.2.5, a cockpit may be accepted as being ‘self-draining’ if:

- it drains overboard; **and**,
- the drain outlets are above the normal laden waterline; **and**,
- the cockpit is watertight to the interior of the vessel at least to a height equal to that of the height of the top of the cylinder valves and other high-pressure components where these are located higher; **and**,
- deck hatches or similar openings below the height of the cylinder valves and other high-pressure components where these are located higher must be fitted with a seal or gasket, and the hatch or opening structures, and the seal or gasket, must be complete and free of signs of damage or deterioration.

Well decks and other recessed deck areas may be accepted as being ‘self-draining’ cockpits at Checks 7.1.1, 7.2.3, 7.2.4 and 7.2.5 if they conform to the above specifications. A ‘self-draining’ cockpit is illustrated below.

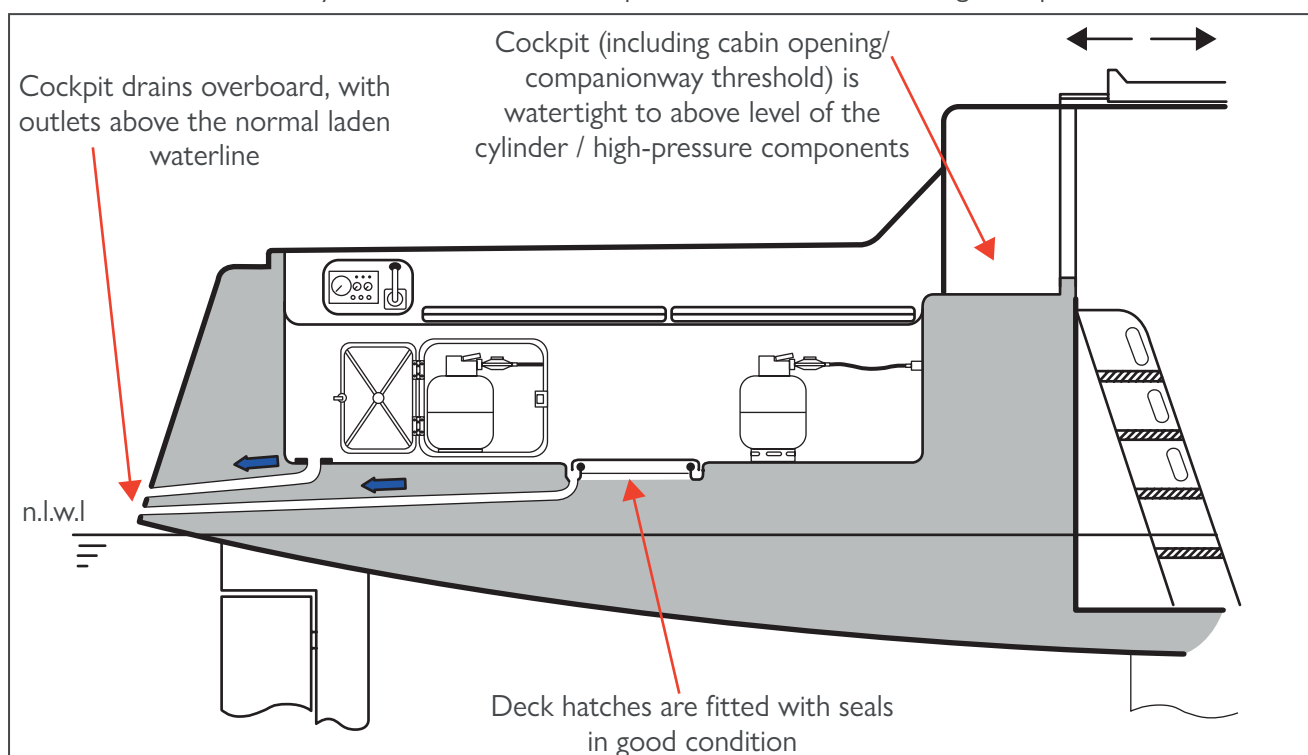



## Appendix 7

### Essential Information

Although no cylinders are present, this photograph adds clarity to how in a 'self-draining' cockpit a threshold/bridge deck is normally present between the cockpit and the cabin opening/companionway to make the cockpit watertight to the interior of the vessel to at least the height of the cylinder valves and other high-pressure components. In this yacht, a cylinder could be stowed in an open location within the cockpit well, or within a housing within the cockpit well, provided the cylinder valve/high-pressure components were lower than the bridge deck into the cabin.

To be accepted as 'self-draining' the visible proprietary deck hatch would need to be fitted with a complete seal around the opening (and be in good condition), and the cockpit would need to drain overboard with the outlets above the normal laden waterline.



### 1.3 'Open transom' cockpits

Check 7.2.4 refers to 'open transom' cockpits.

'Open transom' cockpits are those where, by design and construction, the transom is open or cut away enough to allow pedestrian access on/off the boat. When determining compliance at Check 7.2.3, a cockpit may be accepted as having an 'open transom' if:

- enough of the transom is open/cut away that normal pedestrian access is possible through the transom; **and,**
- the cockpit sole is free-draining overboard through the opening in the transom (there must be no lip or other form of threshold across the opening that would inhibit the free flow of escaping LPG overboard); **and,**
- in cases where there is a gate or door across the opening, or the transom itself can be hinged to form an open transom, when the gate, door or transom is closed the cockpit sole must still be free draining through the transom opening.

Examples of 'open-transom' cockpits are shown below





### 1.4 LPG cylinder lockers and housings

Lockers and housings are both intended to offer protection to cylinders, but they have different characteristics.

**Lockers** are enclosures that:

- are vapour-tight up to the level of the top of the cylinder valves, or other high-pressure components where these are higher; and,
- are fitted with a drain to the outside; and,
- must not open into engine and/or battery spaces.

Lockers are often top-opening, but may be side opening if the locker is on the exterior of the vessel where any escaping LPG vapour (around the door opening) would flow overboard unimpeded.

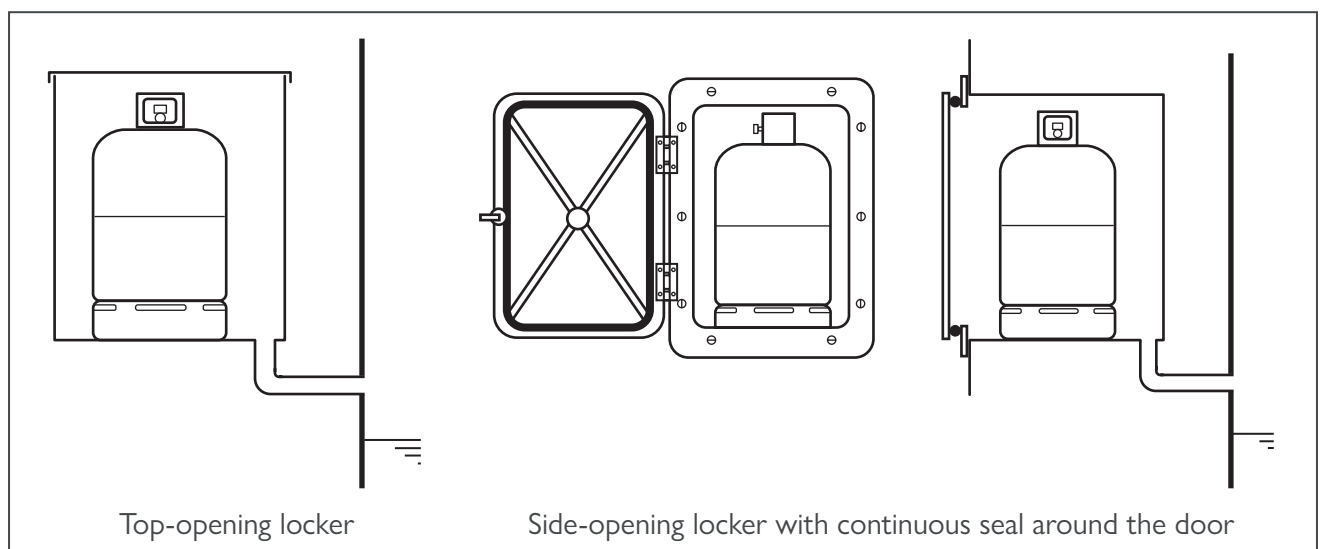

**Housings** are enclosures that provide full or partial protection to cylinders that are in an 'open location'. The term 'open location' means that the cylinder is in a location on the exterior of the vessel where any escaping LPG vapour would flow overboard unimpeded. Therefore, where housings form an integral part of boat structure they must be sealed to the interior of the vessel.

There are no specifications for the extent that a housing must enclose a cylinder(s), so housings may just partially enclose the cylinder, or they may fully enclose the cylinder and include one or more doors.

**Appendix 7**  
Essential Information

Housings are not provided with overboard drains, but if they are fitted with a door(s) then the housing must be permanently ventilated to the exterior of the vessel in some way. The BSS Requirements do not specify the ventilation type, or the minimum free air area, but it is normal to see ventilation provided by way of intended gaps through the doors or within the housing structure, or simply loose fittings doors.

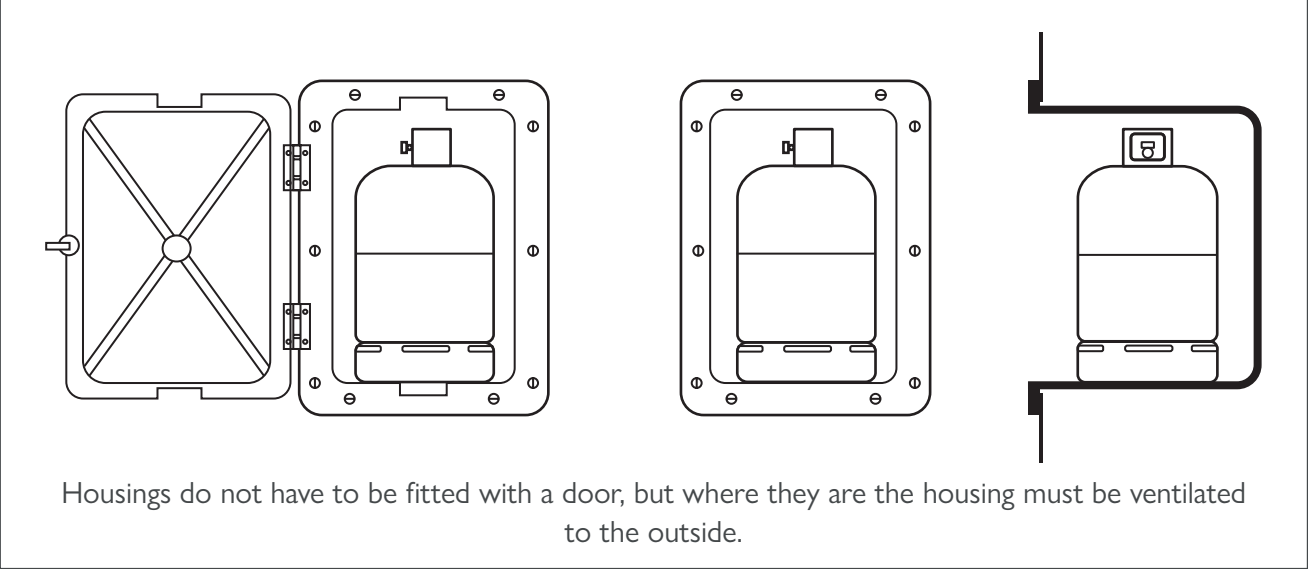

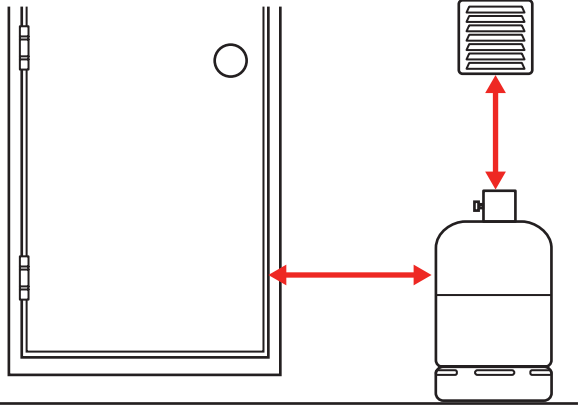
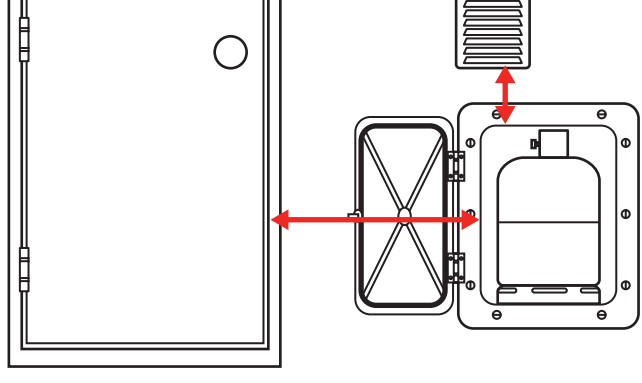
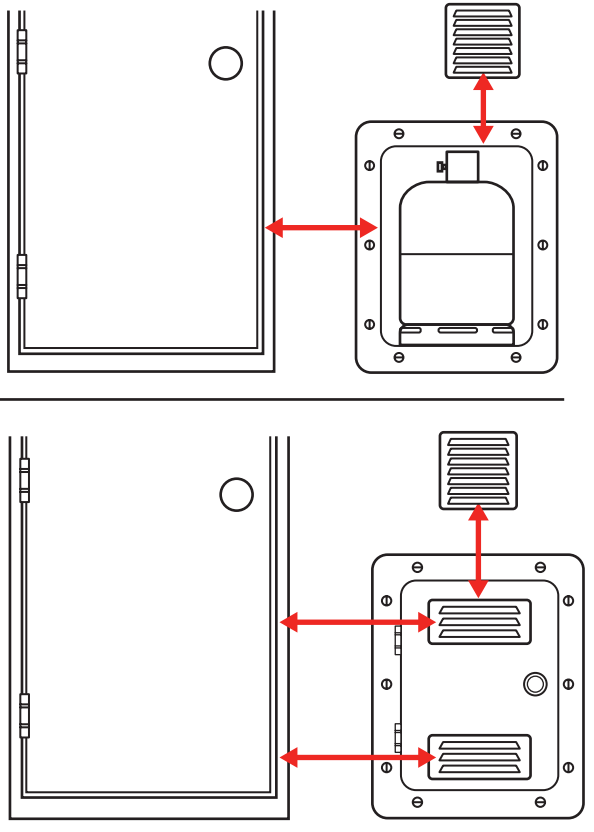

### 1.5 Measuring between cylinders, housings and openings into the interior of the vessel and ignition sources

<p>At Check 7.1.1 cylinders in 'open locations' must not be located within 0.5m of openings into the interior of the vessel or any source of ignition.</p> <p>As shown by the following drawing, the distance to measure is the shortest between the cylinder and any opening into the interior of the vessel (or the source of ignition).</p>	
<p>At Check 7.2.4, side-opening lockers with door openings within 0.5m of an opening into the interior of the vessel, or any source of ignition, must be fitted with a continuous seal around the whole door.</p> <p>As shown by the accompanying drawing, the distance to measure is the shortest between the locker opening and any opening into the interior of the vessel (or the source of ignition).</p>	
<p>At Check 7.2.5 cylinder housing openings must not be located within 0.5m of openings into the interior of the vessel or any source of ignition.</p> <p>As shown by the accompanying drawings:</p> <ol style="list-style-type: none"> <li>1. where the housing has no door the distance to measure is the shortest between the housing opening and any opening into the interior of the vessel (or the source of ignition); or,</li> <li>2. where the housing has a door the distance to measure is the shortest distance between the housing's ventilation provision and any opening into the interior of the vessel (or source of ignition).</li> </ol>	

### **1.6 LPG cylinders stored in outboard wells**

Very occasionally, LPG cylinders may be found permanently located within outboard wells. This is an acceptable storage location at Check 7.1.1 provided the well conforms to the 'self-draining cockpit specifications. Therefore, the well must:

- drain overboard with the outlet(s) above the normal laden waterline; **and,**
- be free of any gaps or other openings into the interior of the vessel at least to a height equal to that of the height of the top of the cylinder valves and other high-pressure components where these are located higher; **and,**
- any hatches within the well (into the interior of the vessel) below the height of the cylinder valves and other high-pressure components where these are located higher must be fitted with a seal or gasket, and the hatch or opening structures, and the seal or gasket, must be complete and free of signs of damage or deterioration.

**2 – Additional information to support BSS Examiners’ understanding of the BSS Requirements**

**2.1 Supporting information to be found in the BSS LPG Training Manual**

Supporting information on the following can be found within the BSS LPG Training Manual:

- Non-return valves**
  - The different types of non-return valves fitted within cylinder connections. (Check 7.7.2)
- Hose connections**
  - Pre-made hose assembly connections for high-pressure hoses. (Check 7.7.3)
  - Suitable nozzles secured by crimped or worm drive clamps for low-pressure hose connections. (Check 7.9.5)
  - Suitable connections for BS 669 and EN 14800 hose assemblies. (Check 7.9.1)
  - Portable appliance hoses connected with bayonet, plug and screwed fittings (Check 7.10.2)
- Regulators**
  - How to recognise manually adjustable regulators. (Check 7.7.6)
- Pipework and connections**
  - Suitable pipe material. (Check 7.8.1)
  - Suitable pipe joints. (Check 7.8.3)
  - Proprietary ‘tools to remove’ end-stops for pipe spurs. (Check 7.8.5)
  - Proprietary ‘tools to remove’ cap or plug for screwed portable appliance connections (Check 7.10.3)
- Isolation valves**
  - Suitable isolation valves. (Check 7.11.2)
- Test points**
  - Proprietary test points on appliances. (Check 7.12.1)
  - Proprietary test points fitted in pipework. (Check 7.12.1)

**2.2 Cylinders lockers or housings of suitable proprietary manufacture**

Check 7.4.5 requires cylinder lockers and housings to be of ‘suitable proprietary manufacture’.

Most cylinder lockers and housings will very obviously be manufactured for the purpose because they will be integral to the structure of the boat but some will be proprietary after-market products.

Examples of after-market cylinder lockers being of suitable proprietary manufacture are provided below. Common features include a drain facility and pipework exit points. Note that the yacht style lockers will likely be made of high-density polyethylene.

			
Yacht cylinder locker	Cruiser cylinder locker	Yacht cylinder locker	Side opening cylinder locker

Where the locker or housing is not obviously of suitable proprietary manufacture, Examiners should apply the material thickness Requirements at Check 7.4.5.

## 2.3 Portable appliances

### Self-contained portable appliances

Self-contained portable appliances are those where the cylinder or cartridge is located within the appliance, or where the appliance and cylinder are part of a portable package, such as with camping gas stoves and space heaters.



Published BSS guidance is that self-contained portable appliances should never be used on board boats as during use there is a risk of fire and/or explosion. However, it is recognised that some boat owners may choose to store such items on board so that on an occasional basis they can be used ashore. When on board, the cylinders or cartridges for self-contained portable appliances must be stored in accordance with Check 7.1.1. Owners may choose to store the whole appliance (with cylinder or cartridge attached) in accordance with Check 7.1.1, or store the disconnected cylinder or cartridge in accordance with Check 7.1.1.

### Portable appliances attached to connection points

Section 7.10 addresses portable appliance connection points.

Portable appliance connection points are relatively rare on boats and are generally associated with FRP yachts with BBQ appliances that can hang over the water from push-pit or pulpit rails.

The connection could potentially be used to supply a gas-powered portable generator/invertor or even blowlamp engine-start supply on a vintage 1910/20s narrowboat.



An LPG BBQ over the stern of a yacht

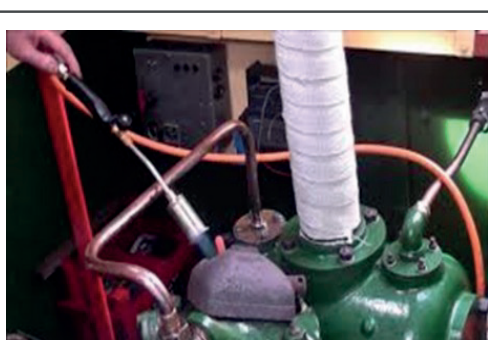

A vintage narrowboat blowlamp engine-start



A LPG-powered portable generator/invertor

It follows that Examiners will need to be vigilant in identifying any portable appliance connection points by following each LPG line spur.



## 2.4 Sealing arrangements for pipework exiting cylinder lockers and housings

There are three compliant types of sealing arrangements from cylinder lockers: bulkhead fittings; cable glands; and sealant.

i) Bulkhead fitting – A bulkhead fitting is a compression fitting allowing connection of an LPG pipe or hose to another LPG pipe, through the cylinder locker bulkhead.

Many builders supply new boats with the bulkhead fitting drilled through as this can allow a length of jointless pipe from inside the gas locker to beside the appliance or ‘tee’ joint. The olives can be still used and provide an effective seal.

Whether the fitting is drilled or not usually cannot be identified by visual assessment and both types are compliant.



ii) Cable gland – Cable glands are designed to attach and secure the end of electric cables to provide strain relief and to seal cables which pass through bulkheads.

They serve a similar purpose providing an effective seal for continuous lengths of LPG pipe passing through a cylinder locker.



iii) Use of sealant – in other possible applications, like the LPG tightness of cylinder locker seams, the use of sealant is not permitted.

The use of sealant is permitted to seal an LPG pipe leaving an LPG locker.

Sealant can be used to seal the LPG pipe through the cylinder locker bulkhead or to seal an LPG pipe within a conduit. The image shows sealant used in both applications.



## 2.5 Cylinder locker drains

### Check 7.3.1

At Check 7.3.1 the Requirement is that cylinder locker drain outlets must be located above the normal laden waterline (n.l.w.l.). However, the Applicability permits there to be an opening(s) below the n.l.w.l. provided the opening(s) above the waterline comply with the Requirement at Check 7.3.6. The following drawings provide added clarity to the Requirement and Applicability at Check 7.3.1.

<p><b>Fig 1a.</b> The drain outlet will be compliant at Check 7.3.1 provided the area of the opening above the n.l.w.l. is compliant at Check 7.3.6.</p>	<p><b>Fig 1b.</b> The drain outlet is not compliant at Check 7.3.1 as it is not above the n.l.w.l.</p>	<p><b>Fig 1c.</b> The drain outlet is not compliant at Check 7.3.1 as it is not above the n.l.w.l.</p>

Although the arrangement at Fig 1 would be compliant with the BSS Requirements, published BSS guidance is that on boats where river/canal water can enter a cylinder locker through a locker drain the owners are advised to regularly assess the condition of the locker to ensure water cannot enter the interior of the vessel. Particularly on lockers made from mild steel the ongoing presence of water in the locker could lead to corrosion, which in turn could lead to river/canal water flooding into the interior of the boat. Owners are therefore also advised to consider changing the cylinder locker arrangement to prevent river/canal water entering the drain and/or locker.

### Check 7.3.2 – Requirement

The Requirement at Check 7.3.2 is that cylinder locker drain openings must be located not greater than 30mm above the lowest point of the locker. The following drawings provide added clarity.

<p><b>Fig 2a.</b> In both these scenarios, height X (lowest point of the locker to the drain opening) is less than or equal to 30mm and therefore meets the Requirement at Check 7.3.2.</p>		<p><b>Fig 2b.</b> Here, height X (lowest point of the locker to the drain opening) is greater than 30mm</p>

### Check 7.3.2 – Applicability

The Applicability at Check 7.3.2 permits an alternative compliance option in cases where drain openings are greater than 30mm above the lowest point of the locker. Such lockers may be accepted as being compliant where the space below the drain opening is filled with a suitable material. The following drawings provide added clarity.

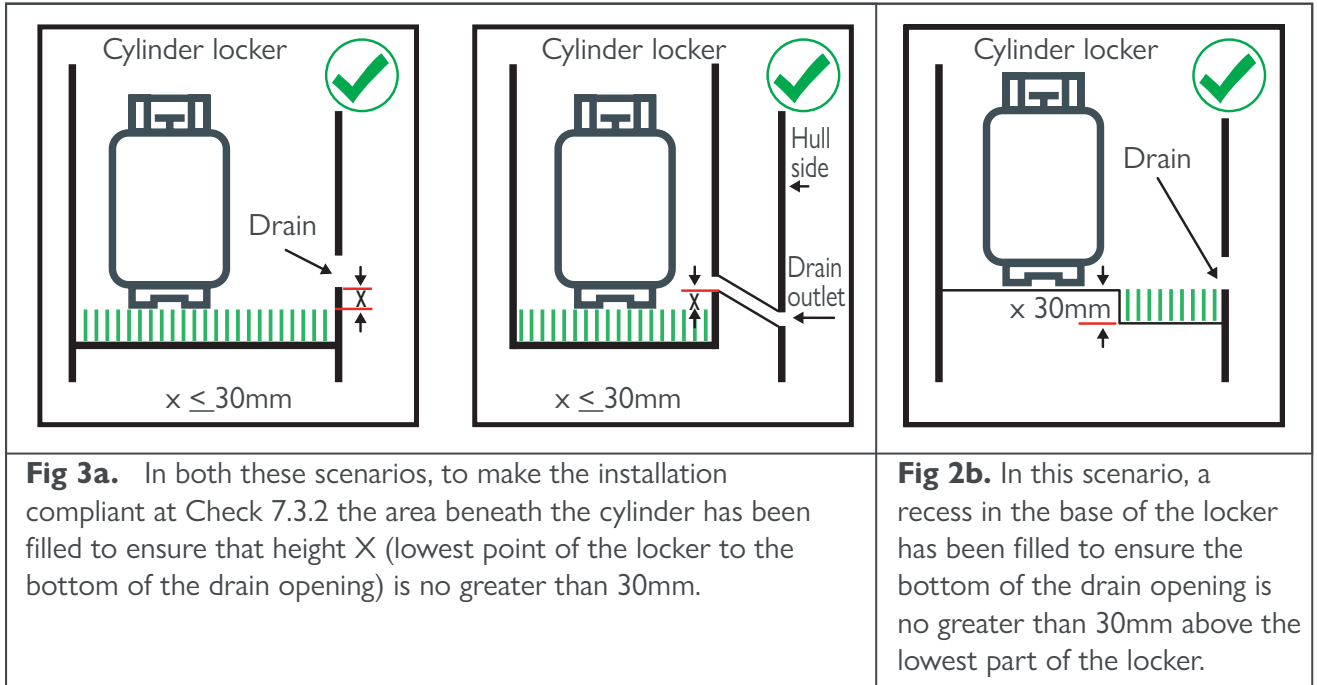

The material used to fill the space beneath the cylinder(s) does not have to be permanently installed, but it must be robust enough that it can support the cylinder(s) in an upright position.

The material used must also be solid enough that any escaped LPG vapour cannot be absorbed (leading to a potentially explosive mix).

The material does not have to completely fill the space, but any gaps or voids should be kept to a minimum. For example, sheets of plywood could be laid in the bottom of a locker to raise the base. The plywood would not have to be laminated in, but any gaps around the outer edges must be kept to a minimum (and ideally any gaps should be filled, for example with a suitable sealant).

Concrete could also be used to completely fill the space beneath cylinder(s), but boat owners are guided to be careful about the compatibility of the material being used to fill the space and the material of the locker. If considering filling the space beneath cylinders to achieve compliance at Check 7.3.2 boat owners are encouraged to seek competent advice from a suitable boatyard or marine surveyor.

**Appendix 7**  
Additional Information

**Check 7.3.4**

The first part of the Requirement at Check 7.3.4 is that Cylinder locker drain lines must be continuous and must fall continuously to the drain outlet in the hull so as not to retain escaped LPG vapour. By falling continuously drain lines cannot retain water which, if it were to lie in the drain line, could block it. The following drawings provide added clarity.

<p><b>Fig 4a.</b> The drain line falls continuously.</p>	<p><b>Fig 4b.</b> There is a U bend in the line which could trap water.</p>	<p><b>Fig 4c.</b> The drain line has a very slight continuous fall.</p>	<p><b>Fig 4d.</b> The drain line rises towards the outlet.</p>

**2.6 LPG pipe joint securing**

According to Check 7.8.4, fixings are required on all sides of joints.

All LPG pipe joints must have fixing clips attached no more than 150mm from each joint connection.

The 'P' clip on the far right of this image is not compliant with the Requirement.



Joints secured by proprietary integral fixings such as mounting plates or bulkhead fittings can be considered as meeting this Requirement.





## 2.7 Non return valves

In circumstances where two or more cylinders are connected on the high-pressure side, a non-return valve (NRV) is required to be fitted in each connection.

It may not always be obvious whether a non-return valve is fitted or not. Most automatic changeover devices will have them, some double wall blocks incorporate them, and some pigtails are supplied with them. Here are some tips to help identify the presence of NRVs.



The wall block in the image is marked with the words 'NRV' to the left and an arrow is marked to the right. The inclusion of the NRV may be indicated by an arrowhead, triangle, or wording. Arrow symbols and triangles will invariably point in toward the device.

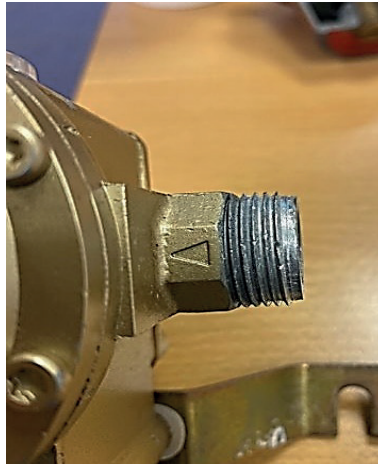

This changeover regulator is marked with a 'triangle' symbol.



This auto-changeover regulator is marked with two arrow symbols

**Appendix 7**  
Additional Information

		
<p>A label may be attached to the hose identifying that an NRV is fitted in the POL connection.</p>	<p>Another example of a label attached to the hose identifying that an NRV is fitted in the POL connection.</p>	<p>If no label is present and no NRV identified in the wall block or changeover regulator; and, if the owner or their representative is present to disconnect the pigtailed, the presence of an NRV can also be identified by a visual examination of the POL connection.</p> <p>Typically, the NRV in the propane POL connection would have a hexagonal shape to it and a ball bearing behind the hexagonal cut-out may also be seen.</p>

In some instances, confirmation of the presence of NRV's will only be possible by physical disconnection of the propane POL connector or butane pigtail; or disconnection of the W20 end of a high-pressure pigtail from a wall block or changeover regulator.

If the owner or the owner's representative is not present, Check 7.7.2 is to be marked 'not verified' until arrangements are made to confirm the presence of NRV's.

Examiners are not permitted to remove the hose from the cylinder during an Examination.

There is no Requirement for Examiners to test if the NRVs are functioning.

## 2.8 Appliance isolation valves

Appliance isolation valves are used where there are appliances connected by hose, and are in place to be able:

- to isolate the appliance's gas supply in the event either the hose has become damaged or its condition has otherwise deteriorated, risking an escape of LPG vapour; or
- to close the gas supply to the appliance whilst the appliance is serviced or temporarily removed for cleaning, etc.

### Check 7.11.1 – 2nd Applicability

At Check 7.11.1 the Requirement is that appliances connected by hose must be provided with an individual shut-off valve in the vicinity of the appliance. However, the 2nd Applicability permits hob/oven arrangements to be treated as one appliance for the purposes of the Check. This means that:

1. Where a hob and separate oven (or oven/grill) are the only appliances on board, and one or both appliances are connected by hose, the cylinder valve(s) may be taken as being the appliance isolation valve. The drawing at Figure 5 provides added clarity.

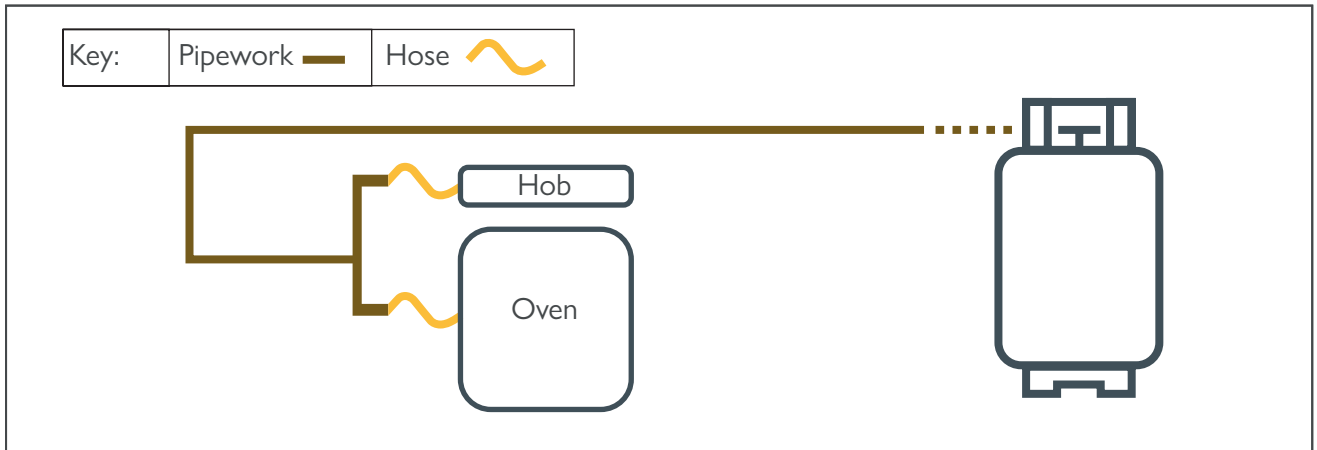

**Fig 5.** This scenario is compliant at Check 7.11.1. Where a separate hob and oven (or oven/grill) are the only appliances the cylinder valve may be taken as the appliance isolation valve irrespective of the distance between the appliances and the cylinder(s).



- Where there are more LPG appliances than just a hob and separate oven (or oven/grill) a single valve may act as the appliance isolation valve for the hob and separate oven provided it is positioned within a spur that only supplies the hob and separate oven. The drawings at Figure 6 and 7 provide added clarity.

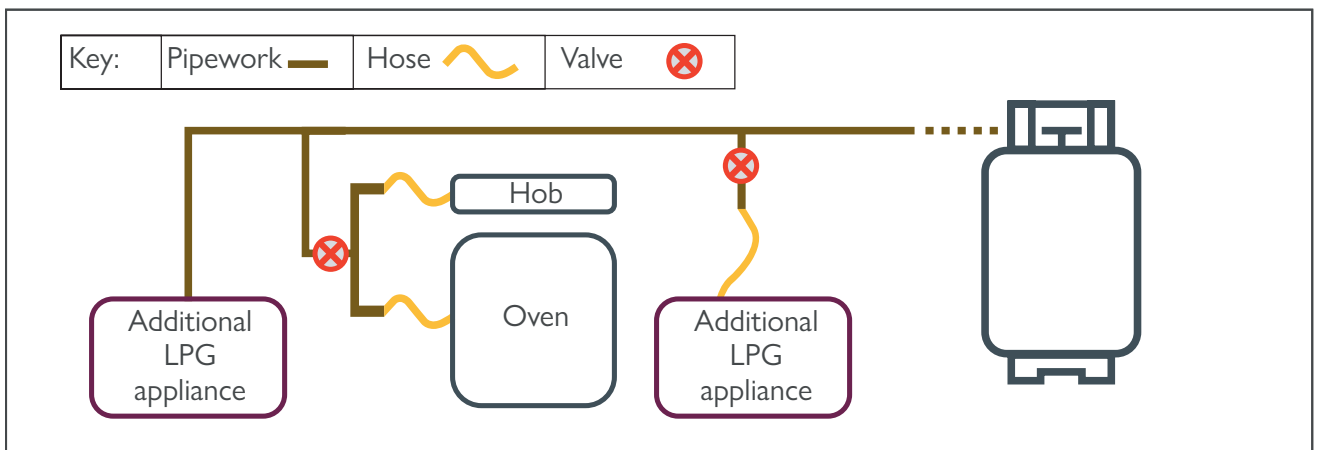

**Fig 6.** This scenario is compliant at Check 7.11.1. Where there are more appliances than just the separate hob and oven (oven/grill) a single isolation valve may serve the hob and oven but it must be in the spur that supplies the two appliances.

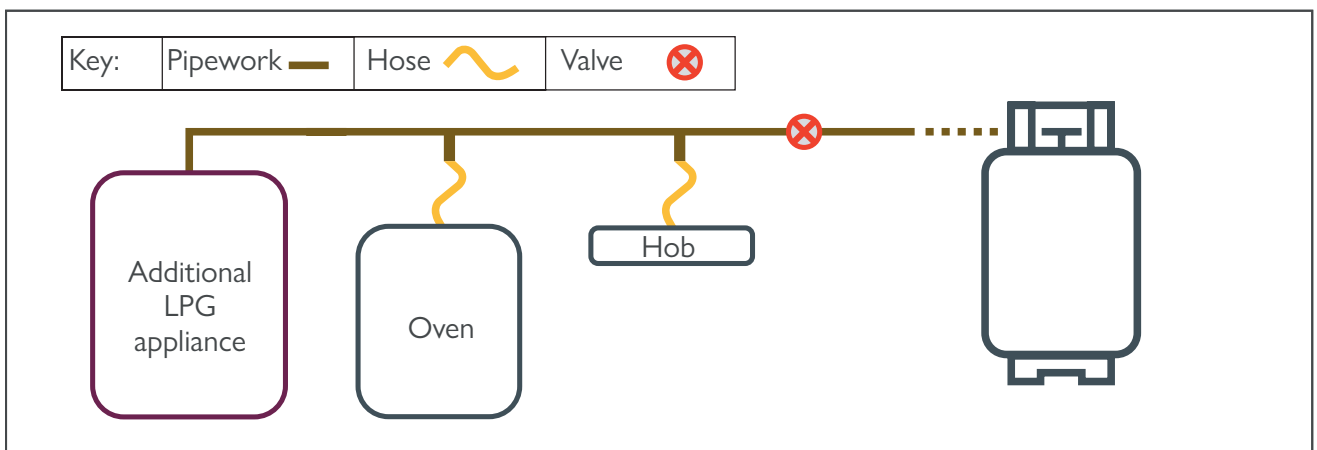

**Fig 7.** This scenario is not compliant at Check 7.11.1. The in-line valve is not positioned within a spur that only supplies the hob and separate oven.





**Appliances and flues**

**1 – Essential material needed by BSS Examiners to be able to apply certain Part 8 Checks**

**1.1 LPG burner flame trouble chart**

At Check 8.8.1 Examiners must assess the flame picture at each LPG appliance burner when **all appliance burners** in the system are operating at their maximum setting at the same time. If you observe one or more of the poor burner flame picture indicators listed below, a fault must be recorded at Check 8.8.1R.

Indicator	Indicator
<b>Yellow flame tip</b>	<ul style="list-style-type: none"> <li>• Insufficient air</li> <li>• Oversize injector</li> </ul>
<b>Orange flame</b>	<ul style="list-style-type: none"> <li>• Particles of dust or dirt being carried through burner ports</li> </ul>
<b>Individual flames lift above burner ports</b>	<ul style="list-style-type: none"> <li>• Too much primary air</li> <li>• Burner ports partially blocked</li> <li>• Too much pressure</li> </ul>
<b>Delayed ignition or slow lighting</b>	<ul style="list-style-type: none"> <li>• Pilot flame incorrectly located</li> <li>• Too much primary air</li> </ul>
<b>Smell of gas</b>	<ul style="list-style-type: none"> <li>• Gas leak</li> <li>• Delayed ignition</li> <li>• No combustion</li> <li>• Cylinder running out of gas</li> </ul>
<b>Combustion odour</b>	<ul style="list-style-type: none"> <li>• Lack of secondary air</li> <li>• Flame impingement</li> <li>• Cylinder running out of gas</li> </ul>
<b>Floating flame</b>	<ul style="list-style-type: none"> <li>• Lack of secondary air</li> <li>• Oven burner gas rate too high</li> <li>• Obstructed flue-way</li> <li>• Draughts</li> </ul>

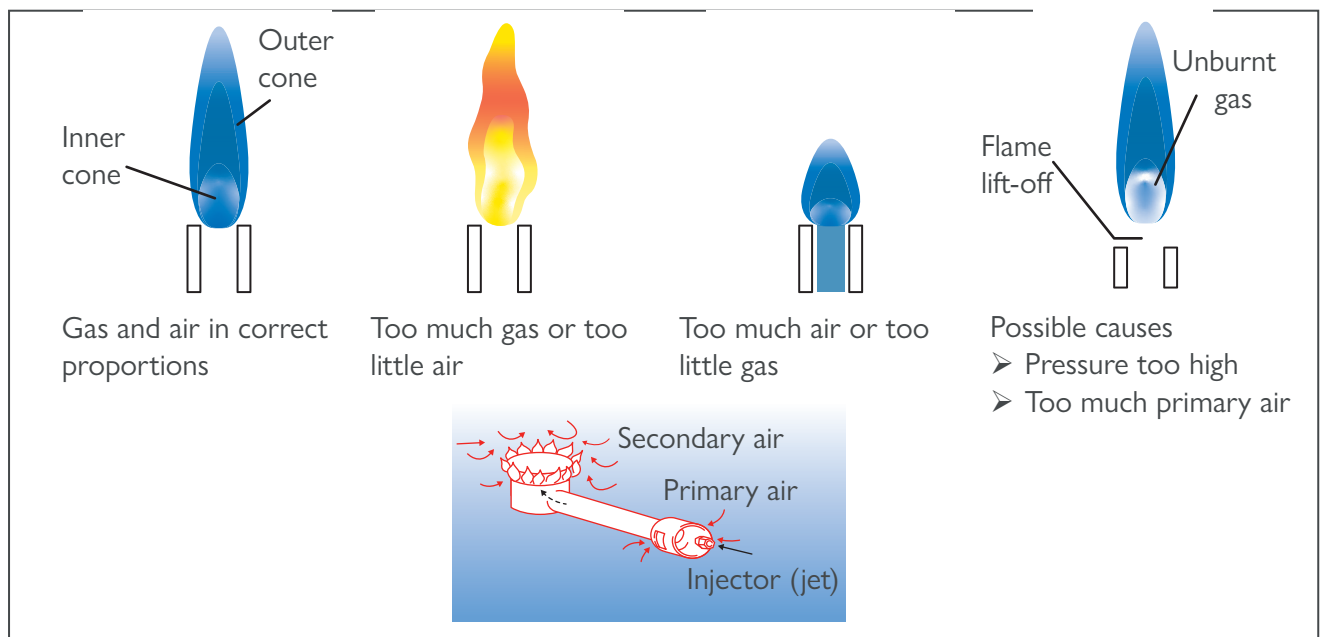

## 1.2 Examining fuel feed shut-off valves for liquid-fuelled appliances

Check 2.13.1 requires that an effective emergency shut-off must be installed in all fuel feed lines and Check 8.1.2 requires that liquid-fuelled appliances must be provided with a valve to shut off the fuel supply. One shut-off valve may achieve compliance at both Checks provided:

- the appliance and the tank are in the same compartment or space (e.g. not separated by bulkheads or similar); and,
- there is a single fuel line from the tank connection to the appliance (i.e. the fuel line from the tank does not feed additional appliances or an internal combustion engine); and,
- the valve is near to the tank; and,
- the valve, or its means of operation, is within reach of the appliance, but not in a position that requires the user to reach over or around the appliance to operate them; and,
- the valve is readily accessible.

Set out below are two examples of scenarios where one valve may achieve compliance at 2.13.1 and 8.1.2:

- a. Many blown air diesel heaters are located within engine spaces with a dedicated fuel feed coming from the boat's main fuel tank (also located within the engine space). In such an arrangement the heater's electrical metering pump may satisfy the Requirements at Check 2.13.1. and 8.1.2.
- b. Diesel stoves such as those manufactured by Reflex often have a dedicated tank located close to and within the same space as the stove. In such circumstances, a manual shut-off valve at the tank may satisfy the Requirements at Check 2.13.1. and 8.1.2.

## 1.3 Securing of solid fuel appliances

Suitable securing methods may include:

- Screw and/or bolt fastenings directly through the appliance's frame or feet;
- The appliance's feet being embedded in concrete, or similar;
- The appliance's feet, or some other part of its frame, being securely held down by independent brackets, framework etc (using screw/bolt fastenings);
- The appliance's feet, or some other part of its frame, being securely held down by weld to a suitable, secure, base;
- The appliance's feet being secured tightly within a framework (e.g. the upstands around a suitable, secure, tray).

Unless expressly approved by the appliance manufacturer, the following methods should normally be considered as not providing suitable securing:

- Sealant, such as silicone;
- Glue, or adhesives;
- Back boiler pipes;
- Chains.

Solid fuel appliances, including stoves and ranges, must be secured at a minimum of two separate locations. Where only two securing points are in place they should be spaced as far apart as practicable. Ideally, if only two securing points are in place, they should be on diagonally opposing corners, but this is not a BSS Requirement.

Although not a BSS Requirement, boat owners are encouraged to have solid fuel appliances secured as recommended by the appliance manufacturer for installation in small craft. Where such installation instructions do not exist, owners are recommended to seek advice from a competent installer.



### 1.4 Wilderness Boats conversion of the Electrolux RM 212 fridge

At Check 8.2.1 Examiners may have to identify a Wilderness Boats modified Electrolux RM212 LPG fridge. During the 1980/90s Wilderness Boats modified approximately 70 RM212 fridges to seal the burner and flue system to enable the appliances to be used on petrol-engined boats (mostly the Wilderness Trailboat). The modified fridges were supplied with a written declaration, an example of which is shown. Some fridges may also carry a label confirming they were modified by Wilderness Boats.

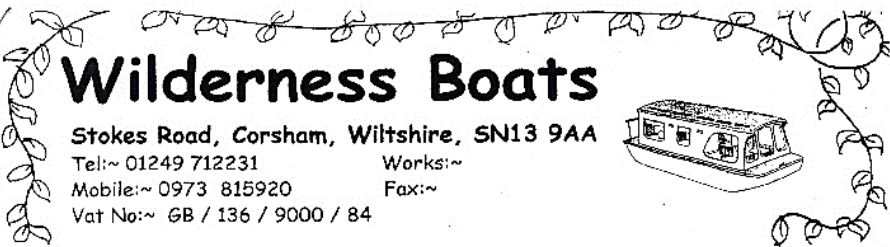

## Wilderness Boats

**Stokes Road, Corsham, Wiltshire, SN13 9AA**  
 Tel:~ 01249 712231      Works:~  
 Mobile:~ 0973 815920      Fax:~  
 Vat No:~ GB / 136 / 9000 / 84

Date:

TO WHOM IT MAY CONCERN

L.P. Gas Fridges - Fire Safety in Petrol Driven Craft

WILDERNESS CANAL & River Craft.

The Electrolux RM 212 gas-operated 'fridge installed in this craft has been fitted with a sealed burner enclosure which has a copper flame-arrester gauze.

A similar sealed gauzed enclosure has also been attached to the exhaust flue "lazy tee".

The gauze employed complies with the specification set out in former National Rivers Authority's "Thames Launch Safety Specification 1989" and with the requirements of sections 8:1 & 8.2 of the Boat Safety Scheme.

Additional low-level through-hull ventilation is provided behind the 'fridge for cooling purposes.

Each 'fridge is subject to an L.P.G. ignition test and is bench tested for 48 hours before being reinstalled.

The fitting of the burner enclosure to such fridges is undertaken by ourselves for each owner on the understanding that the unit is returned to ourselves for servicing when necessary. Compliance with the manufacturers service intervals is recommended.

BOAT NAME/TYPE:

OWNER: BOAT REG.NO.

ADDRESS:

Ian Graham  
Proprietor.

Proprietor:~ I Graham      **Builders of trailable boats for more than 25 years**

Wilderness Boats converted three models of the Electrolux RM 212, model A, B and F, shown below:



**Appendix 8**  
Essential Information

At Check 8.2.2 Examiners must also see documentary evidence from Wilderness Boats, or a Gas Safe registered engineer that the fridge has been serviced within the 12 months prior to the date of the Examination.

The documentary evidence from Wilderness Boats must be on its headed paper, and any documentary evidence from a Gas Safe registered engineer will need to show the name and/or, the name of the company, and a Gas Safe registration number.

Check 8.2.2 also requires Examiners to see the flame arresting mesh on the flue pipe's 'lazy tee', and the flame arresting mesh that encloses the burner.

As originally installed in Wilderness Trailboats access was made through the surrounding structures to allow Examiners visual access to the 'lazy tee' and the burner. Examiners are only required to establish that flame arresting mesh is present on the 'lazy tee' and around the burner.

The following sketch shows the general location of the 'lazy tee' and the burner, and the photographs show close-ups of both items.

**MODIFICATION OF GAS FRIDGE (Electrolux RM212)**  
to overcome explosion hazards from petrol fumes or butane/propane leakage.

Optional louvre vent above unit for cooling purposes if no ventilation to sides

Standard Electrolux external vent kit for discharge of combustion gases

Beated brass mesh to back of lazy-tee fitting

Totally sealed brass-meshed burner enclosure (28x28 holes per lin. inch)

9"

WORKTOP

GUNWALE

3 additional breather holes in upper hull side

REVISED inlet air vent, now fitted at A and ducted downwards

SHELF

Revised ICG March '97 (Lazy-tee) ICG, S March '95

**WILDERNESS BOATS**  
STOKES RD, CORSHAM, WILTSHIRE  
SN13 9AA Tel (01249) 712231  
Builders of trailable boats for over 20 yrs

Additional information on the Wilderness Boats conversation of the Electrolux RM212 fridge can be found in the Help Centre on the BSS Examiner Community.





**2 – Additional information to support BSS Examiners’ understanding of the BSS requirements**

**2.1 Check 8.10.4 – flue spillage testing on LPG instantaneous water heaters**

Examiners should not undertake a flue spillage test (see Appendix E) on an instantaneous water heater if:

- a fault has been recorded at Check 8.10.2 due to the draught diverter and/or flue not being complete and in good condition; or,
- a fault has been recorded at Check 8.10.3 due to the flue terminating inside the boat (including in areas enclosed by canopies); or,
- there is no flue pipe connected to the draught diverter; or,
- a Tannoy vent, or similar, is in use as the flue terminal.

The following photographs show examples where no flue pipe is connected to the draught diverter, where a Tannoy type vent has been used as a flue terminal and where the terminal is in an area enclosed by a canopy

	
<p>Example of an IWH with no flue pipe fitted to the draught diverter</p>	<p>Example of a Tannoy type ventilator (in this case it’s a Vetus vent) being used as an IWH flue terminal (inside a covered cockpit)</p>

If for any reason the flue spillage test cannot be carried out Examiners must mark their checklist ‘not verified’. Therefore, if the spillage test has not been undertaken for any of the reasons bullet-pointed above, or if there was not enough water and/or gas to be able to run the heater for the required period, Examiners must record Check 8.10.4 as ‘not verified’. This means that the Check has not been completed; whatever issue meant the flue spillage could not be undertaken must be rectified by the owner to enable the spillage test to be undertaken. Examiners cannot issue ‘pass’ Certifications (e.g. ‘Yes’, or ‘Yes, but some Advice checks did not pass) where compliance at one or more relevant Checks is ‘not verified’.



## Appliances and flues

### Requirements for fixed ventilation (Check 8.9.1)

Fixed ventilation is ventilation that cannot be closed without the use of tools.

Note 1 – Ventilators, doors, windows, hatches and any other openings, which can be fully closed, must not be included in the ventilation calculation.

Note 2 – Ventilators, doors, windows, hatches and any other openings, modified so they cannot be fully closed without the use of tools should only have their minimum fixed ventilation area included in the calculation.

### Factors Affecting Total Effective Area of Fixed Ventilation

The total effective area of fixed ventilation is the total area of fixed ventilation provision, as measured.

Each ventilator, door, window, hatch and any other openings should be measured carefully to determine their individual effective area of fixed ventilation.

Careful examination must be made of each ventilator to determine the presence of any device which would reduce the clear air opening e.g. filter, insect screen, fan blades.

Where filters or screens are fitted, they must also be in a clean and serviceable condition as partial or complete blockage of the clear air openings could make the ventilator totally ineffective.

Louvered doors are a common form of providing fixed ventilation and the effective area needs to be carefully measured.

The total effective area of fixed ventilation is designed to provide:

- combustion air for appliances that are not room-sealed;
- for the evacuation of combustion products from appliances that are not room sealed;
- renewal of fresh air for habitation and comfort.

### Calculation of Fixed Ventilation Requirements

**The formula used to calculate the fixed ventilation requirement is derived from PD 54823 Annex C (Guidance for the design, commissioning, and maintenance of LPG systems in small craft), but as extended by BS 8511 Annex A (Code of Practice for the Installation of Solid Fuel Heating and Cooking Appliances in Small Craft) to address solid fuel stoves and other appliances.**

The formula for calculating the fixed ventilation requirement 'V' (in mm<sup>2</sup>) is as follows:

**V** = [2200 × U] + [650 × P] + [550 × H] + [440 × F], where:

**U** = input rating for all unflued appliances (inc. cookers) (in kW)

**P** = number of persons for which the accommodation space is designed

**H** = nominal output rating of all solid fuel appliances (in kW)

**F** = input rating for all open-flued appliances (in kW)

### Open-Flue and Closed-Flue Appliances

From the Glossary definition, 'open-flue' appliances take their air for combustion from the space in which they are installed. Open-flue appliances can be identified by the presence of a draught diverter which provides a draught break between the primary flue on the appliance and the secondary flue connecting the draught diverter and the flue terminal.

Closed-flue appliances also take their air for combustion from the space in which they are installed, but the flue is closed from the space due to the absence of a draught diverter. Because closed-flue appliances take air for combustion from the space in which they are installed, such appliances must be included within 'F', when making the calculation.

### **Number of persons for which the accommodation space is designed**

#### Privately owned or managed boats –

For boats built to the Recreational Craft Regulations/Directive, 'P' is to be taken as the maximum number of persons stated on the Builder's plate, or as recorded on the craft's Declaration of Conformity which may be found in the boat's Owner's manual.

Where the boat has not been built to the RCR/D, or where the marking or documentation is not available, 'P' may be established from the number of berths, including dinettes and other convertible arrangements.

#### Hire boats –

The value 'P' is the maximum number of hirers that the hire operator permits to use the boat, this includes relevant day, overnight, weekly and extended period hire boats. So, on a hire boat let out for overnight hire with 6 persons, but let out for day hire with 9 persons, 'P' must be taken as 9. Examiners must establish P from the hire operator.

### **Establishing the heat input ratings of the fuel burning appliances**

Input ratings for appliances (output ratings for solid fuel appliances) can be established from:

- data plates on the appliances, **or**;
- the BSS Office's record of appliances and their kW ratings, **or**;
- manufacturer's information, including from the internet, **or**;
- in the absence of a readable data plate, an output rating of 5kW may be assumed for solid-fuel stoves. For larger solid fuel appliances, such as ranges, Examiners must establish the actual kW rating.

In the event Examiners are stuck and cannot establish the necessary heat input/output information, the BSS Office should be contacted for guidance.

### **High-Level and Low-Level Ventilation (50:50 split)**

To achieve a pass at Check 8.9.1 the total effective area of fixed ventilation (at least up to the calculated fixed ventilation requirement) should be divided as equally as practicable between high-level and low-level.

Note - where the total effective area of fixed ventilation exceeds the calculated fixed ventilation requirement there is no Requirement for the excess fixed ventilation provision to be divided as equally as practicable between high-level and low-level.

Examiners are guided that ideally the split should be equal (50% at high level and 50% at low level) and that in most cases this will be achievable. However, up to a 10% divergence is acceptable. For example, if the Requirement is for a minimum of 10,000mm<sup>2</sup> at high level and 10,000mm<sup>2</sup> at low level, a pass can be recorded if there is up to a 10% divergence from these figures (e.g. it would be acceptable for the low level effective fixed ventilation to be as low as 9,000mm<sup>2</sup> provided there was at least 11,000mm<sup>2</sup> at high level or vice versa).

Low-level ventilation can be achieved by spillage of cold air from vents in doors and/or bulkheads or by means of ducting from a higher level.

### Application of the fixed ventilation calculation

The calculation should be applied to any part of the vessel containing a fuel burning appliance that:

- is normally divided as a separate compartment;
- can be temporarily divided except by curtaining.

Therefore, where fuel burning appliances are located in separate accommodation spaces, the calculation must be applied to each accommodation space. For example, if a centre cockpit cruiser has a galley in the aft cabin with an LPG cooker, and an LPG heater in the cabin forward of the cockpit, separate calculations must be undertaken for the aft cabin and forward cabin.

### Recording appliances, the fixed ventilation calculation(s) and all effective fixed ventilation

Examiners should gather and maintain the following information for all 'Yes' and 'Yes, but some Advice checks did not pass' result Examinations:

- i. the make, type and input rating of all fuel burning appliances
- ii. the ventilation calculation performed (for each separate accommodation space containing fuel burning appliances)
- iii. the effective fixed ventilation provision (for each separate accommodation space containing fuel burning appliances)

To support this, Examiners are asked to create an Appliance record on the BSS database for all 'Yes' and 'Yes, but..' result Examinations. Where Examiners chose not to create an Appliance record on the BSS Database they must keep Section 3 of the BSS Examination Record Form (or equivalent) within their personal files for a minimum of six years.

Examiners must record the make, type and input rating of all:

- room-sealed/balance flued fuel burning appliances; and,
- fuel burning appliances taking their air for combustion from within engine spaces (see additional information below)

even though these appliances are not included within the fixed ventilation calculation.

### Ventilation through cockpits with canopies

To enable any ventilators into cockpits or well decks enclosed by canopies (e.g. high and/or low-level ventilators in external bulkheads or cabin doors) to function properly, ventilation should be provided through or around the canopy to allow air flow from outside the boat to the vents. If the canopy is loose fitting with gaps between it and the boat's permanent structure and/or between separate canopy panels, then specific vent openings are not required through the material of the canopy. In such circumstances, Examiners are not required to measure the gaps between the canopy material and the boat's permanent structure.

### Ventilators in series

As shown by the following drawing, it is acceptable for low level ventilation pathways to pass through other compartments or accommodation spaces enroute to the appliance(s) and for the high level ventilation pathways to pass through other compartments or accommodation spaces enroute to outside the craft. However, in such circumstances Examiners need to take care to ensure that the effective fixed ventilation through each of the vents in series is large enough to meet the fixed ventilation Requirements.

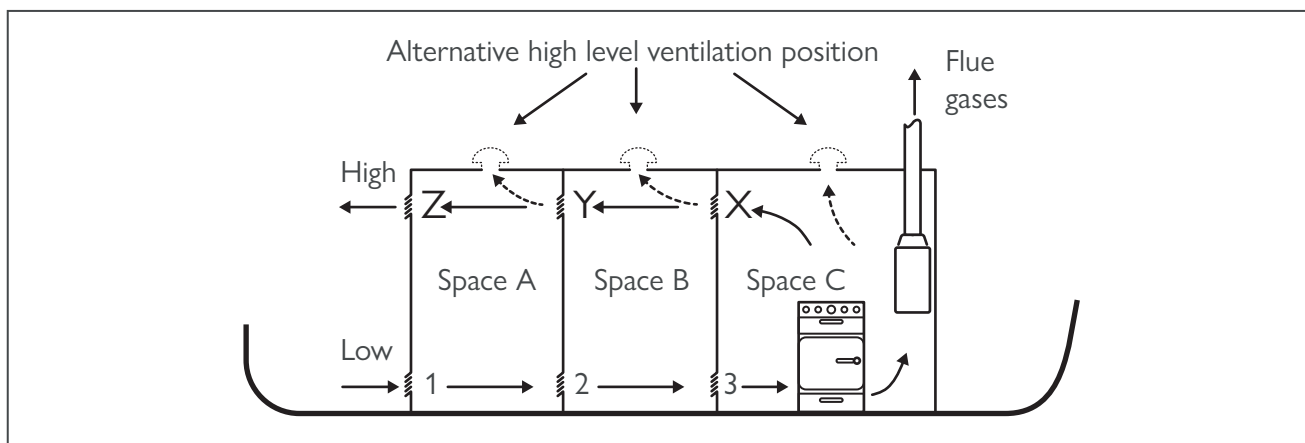

**Ventilation ducted through compartments**

Ventilators at high level (e.g. in a cabin roof) do not always provide high-level ventilation!

For example, if there is a Tannoy vent in the cabin roof within a toilet compartment, but there is no high-level fixed ventilation through from the toilet compartment into the main accommodation spaces where the fuel burning appliances are installed, then the vent cannot be accepted as contributing to the high-level fixed ventilation.

However, if there is no high-level fixed ventilation through from the toilet compartment into the main accommodation spaces where the fuel burning appliances are installed, but there is fixed low-level ventilation, then the toilet compartment can be accepted as ducting. Cold, fresh air can enter through the Tannoy, spill down through the toilet compartment and enter the main accommodation space at low-level. In this scenario, the effective area of the ducted ventilation will be the smaller of the two areas (mm<sup>2</sup>) provided by the Tannoy or the low-level fixed ventilation from the toilet compartment into the main accommodation space.

**Fuel burning appliances within engine spaces**

When establishing the fixed ventilation Requirements at Check 8.9.1, Examiners are not required to include fuel burning appliances located within engine spaces (if the combustion air is being drawn from the engine space) within the calculation. This is because engine spaces are normally vented directly to outside the vessel.

Such appliances must be listed on the Examiner’s Appliance Record at the time of the pass Examination, but their kW rating does not need to be included within the fixed ventilation calculation.

**Ventilation pathways through engine spaces**

Fixed ventilation for accommodation spaces should not pass-through engine spaces unless the pathway is through sealed ducting.

**The actual height of high and low-level ventilators**

Examiners must be aware that low-level ventilation can be achieved by spillage of fresh air from vents in doors and/or bulkheads or by means of ducting from a higher level, and that high-level ventilation need not be on the cabin roof and can be high up on the cabin sides. There are no hard-and-fast rules, there must simply be a pathway for cold fresh air to spill into the relevant accommodation space at low level and for the products of combustion to pass out of the accommodation space to outside the boat at high level.

**Appliances in cupboards, or other similar locations**

To meet compliance with Check 8.9.1, appliances in cupboards should be provided with adequate fixed ventilation for combustion through the cupboard structure as specified by this Appendix.

Examiners should also pay particular attention to surfaces surrounding the appliance for signs of heat damage (Checks 8.4.1 and 8.5.1).

Appliances in cupboards should be provided with additional ventilation at high and low level for cooling purposes, but this is not a BSS Requirement.

**Ventilation for the comfort of craft occupants**

For boats that have no fuel burning appliances, (or that have only room-sealed appliances) boat builders should provide a small amount of fixed ventilation to take into account the air consumption and comfort of the occupants of the spaces and, perhaps to address condensation build up affecting boat structures and furnishings.

However, this is not a BSS Requirement and Examiners must only apply Check 8.9.1 where there are non-room-sealed fuel burning appliances onboard.





**Pollution prevention**

**1 – Essential material needed by BSS Examiners to be able to apply certain Part 9 Checks**

There is currently no essential material supporting the Part 9 Checks.

**2 – Additional information to support BSS Examiners’ understanding of the BSS Requirements**

**2.1 Bilge water filters with 5 parts per million (ppm) performance levels**

For bilge water filters made by the following two main UK manufacturers, all models can be presumed to meet the 5ppm performance level as the BSS has confirmation in the form of manufacturer declarations. The manufacturer’s declarations can be seen in the Help Centre on the BSS Examiner Community.

- Wavestream
- Bilgeaway



**Wavestream bilge filters**

There are currently four models in the range: Micro, WSS 1, WSS 2 and WSS 3.



**Bilgeaway bilge filters**

There are currently four models in the range: Midi (separate photo), 10inch, 20inch and 20inch chrome.



For other makes and models of bilge water filter Examiners must assume that they do not meet the BSS Requirements unless supported by a suitable declaration from the manufacturer expressly confirming 5ppm performance level.

## 2.2 Recognising overboard discharge lines and the presence of an appropriate closable valve

‘Overboard discharge’ means that the contents of the toilet go overboard into the watercourse. For boats having cassette or composting toilets or, holding tanks that only discharge via a shore pump-out, the toilet contents cannot be pumped into the waterway and therefore the Check is not relevant.

The plumbing arrangements on toilets with overboard discharges can be difficult to identify and follow and especially in cases where the owner is not on board to ask. Examiners may need to strive to follow the route of toilet discharge lines in out of view locations such as lockers, cupboards and in bilges.

Examiners should not presume that the presence of a holding tank with a pump-out deck fitting means that there is no overboard discharge line in the system. As shown by the accompanying drawing, some boats will have both overboard discharge and a shore pump-out facility.

Closable valves will generally be found at the through-hull fitting. Valves in this location protect the boat from the sinking risk should the hose connection fail and will generally be readily accessible to allow emergency operation. Very occasionally there may be no valve at the through-hull fitting, but there may be a valve at another point along the discharge line.

The following are examples of toilet and holding tank arrangements with overboard discharge lines.

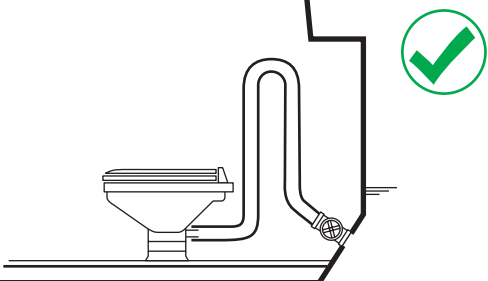
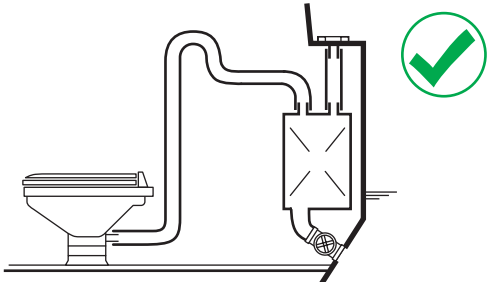
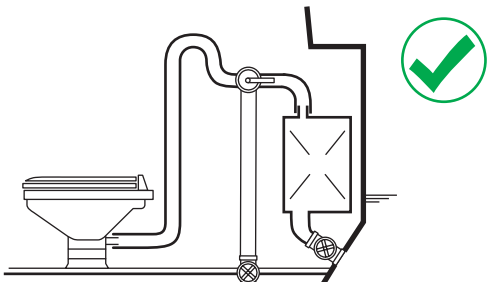
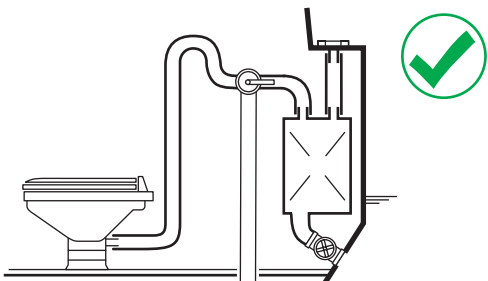
<p>Simple sea toilet with a gate valve at the through-hull fitting. Compliant.</p>	
<p>Holding tank with overboard discharge and shorepump out facility. The overboard discharge is fitted with a valve at the through-hull fitting. Compliant.</p>	
<p>Holding tank with overboard discharge and an overboard discharge bypass arrangement. Both overboard discharge lines have a valve at the through-hull fitting. Compliant.</p>	
<p>Holding tank with overboard discharge and shore pump-out facility, and a discharge bypass arrangement. Even though there is no closable valve at the bypass line's through-hull fitting, the arrangement is compliant at Check 9.2.1. because the Y valve can be used to close off the bypass line and there is a closable valve on the holding tank's overboard discharge line.</p>	

**Section 2 – Checklist for Private Boats** - Examiners must complete a checklist for all Examinations and retain a copy on file for 6 years minimum.

**Examination One (E1)**

Date : Terminated early: Y / N

**Examination Two (E2)**

Date: Terminated early: Y / N

 = BSS Warning Notice must be issued if fault is recorded

 = BSS Warning Notice may need to be issued

 = BSS carbon monoxide leaflet must be issued if fault is recorded



 = Guidance for owners may need to be issued











Mark E1 / E2 as appropriate: P= pass / F= fault / NV= not verified / NR= not relevant

Part 2	Permanently installed fuel systems and fixed engines	E1	E2
<b>2.1</b>	<b>Fuel filling points</b>		
2.1.1R	Does the location and condition of the fuel filling point ensure that any fuel overflow is prevented from entering the interior of the vessel? 		
2.1.2R	Is the fuel in use correctly and clearly marked on or adjacent to the fuel filling point?		
2.1.3R	Are all disused fuel filling points disabled?		
2.1.4R	Does the internal diameter of the fuel filling point meet the specified requirements?		
<b>2.2</b>	<b>Fuel filling lines</b>		
2.2.1R	Are the fuel filling line connections free of signs of leaks and in good condition, and are all fuel filling hose connections accessible for inspection?		
2.2.2R	Is the fuel filling line self-draining so that fuel is not retained and is it free of kinks or other restrictions?		
2.2.3R	Is the material of the fuel filling line suitable and in good condition?		
<b>2.3</b>	<b>Fuel tank vents</b>		
2.3.1R	Does every fuel tank have a vent facility?		
2.3.2R	Does the fuel tank vent line have a minimum internal diameter of 9.5mm (3/8in)?		
2.3.3R	Are the fuel tank vent line connections free of signs of leaks and in good condition, and are all vent hose connections accessible for inspection?		
2.3.4R	Is the fuel tank vent line self-draining so that fuel is not retained, and is it free of kinks or other restrictions?		
2.3.5R	Is the material of the fuel tank vent line suitable and in good condition?		
<b>2.4</b>	<b>Fuel tank vent outlets</b>		
2.4.1R	Does the fuel tank vent outlet, or the vent line swan neck, rise at least as high as the filling point?		
2.4.2pR	Are petrol tank vent outlets fitted with a suitable proprietary flame arrester in good condition?		
2.4.2dR	Are diesel tank vent outlets in good condition?		
2.4.3R	Is the fuel tank vent outlet in a position where no danger will be incurred from leaking fuel or escaping vapour?		

**Notes**

<b>2.5</b>	<b>Fuel tank design and condition</b>		
2.5.1R	Are non-integral fuel tanks incapable of movement under light manual force? (G?)		
2.5.2R	Are fuel tanks made of suitable materials?		
2.5.3R	Are fuel tanks, including seams and openings, in good condition and free of signs of leaks?		
2.5.4R	Are fuel tanks within engine spaces suitably fire resistant or otherwise protected against the effects of fire?		
2.5.5R	Are petrol tanks installed at the required distances from heat sources or protected by a heat baffle?		
<b>2.6</b>	<b>Fuel gauges</b>		
2.6.1R	Are petrol tanks free of glass, or plastic tube, or strip-type fuel gauges?		
2.6.2R	Are any glass or plastic tube or strip-type fuel gauges closely coupled to the tank, fitted with a self-closing valve and in good condition?		
2.6.3R	Are all fuel gauges and level-indicators in good condition and free of signs of leaks?		
2.6.4R	Are fuel tank openings for dipsticks closed by a fuel-tight cap or fitting?		
<b>2.7</b>	<b>Petrol fuel system electrical bonding</b>		
2.7.1R	Are all metallic components in the petrol filling and tank system electrically bonded to earth?		
2.7.2R	Are all parts of electrical bonding systems in good condition? (G?)		
<b>2.8</b>	<b>Fuel tank connections</b>		
2.8.1R	Are any fuel tank drains closed with a plug or cap, or valve, which can only be opened with tools, and are the drains and their connections in good condition and free of signs of leaks?		
2.8.2R	Are the petrol feed line connections in lift-pump systems made to the top of the tank?		
2.8.3R	Is the petrol feed line on a gravity system fitted with a valve directly attached to the tank?		
2.8.4R	Are tank connections accessible for inspection?		
2.8.5R	Are any unused tank connections closed with a plug or cap which can only be opened with tools, and are unused connections in good condition and free of signs of leaks?		
<b>2.9</b>	<b>Fuel tank balance lines</b>		
2.9.1R	Are multiple petrol tank systems free of balance lines?		
2.9.2R	Are balance lines on diesel tank systems made of suitable materials and are they in good condition and free of signs of leaks?		
<b>2.10</b>	<b>Fuel feed return and on-engine lines</b>		
2.10.1R	Are all fuel feed, return and on-engine pipes made of suitable materials?		
2.10.2R	Are all fuel feed, return and on-engine hoses suitable for the fuel used and fire resistant?		
2.10.3R	Are all feed, return and on-engine pipes secure and in good condition?		
2.10.4R	Are all fuel feed, return and on-engine hoses properly supported and in good condition?		
2.10.5R	Do the diesel injector leak-off (spill rail) arrangements meet specified Requirements?		
<b>2.11</b>	<b>Fuel feed return and on-engine fuel line connections</b>		
2.11.1R	Are all fuel line connections of the correct type and free of signs of leaks?		
2.11.2R	Are fuel hose connections made with hose clips or clamps effective and in good condition?		
2.11.3R	Are all fuel line connections, valves, fittings and other components secure?		
<b>Notes</b>			

<b>2.12</b>	<b>Fuel filters</b>		
2.12.1R	Are fuel filters in good condition?		
2.12.2R	Are all fuel filters inside engine spaces fire resistant?		
<b>2.13</b>	<b>Fuel shut-offs</b>		
2.13.1R	Is an emergency fuel shut-off installed in every fuel feed line?		
2.13.2R	Are all fuel shut-off valves, or their means of operation, in a readily accessible position?		
2.13.3R	Are all fuel shut-off valves, or their means of operation, in open view, or their location clearly marked?		
2.13.4R	Are petrol gravity-fed fuel lines provided with the required fuel shut-off facilities?		
<b>2.14</b>	<b>Carburettors</b>		
2.14.1R	Are all non-down-draught carburettors fitted with a drip tray?		
2.14.2R	Is the carburettor drip tray in good condition, free of signs of leaks, and easily emptied?		
2.14.3R	Is the carburettor drip tray fitted with effective flame arresting gauze permanently attached along all edges?		
2.14.4R	Is the petrol engine air intake fitted with flame trap or air filter?		
<b>2.15</b>	<b>Engine installation</b>		
2.15.1R	Are all parts of engine mounting systems secure and in good condition?		
2.15.2R	Are the structures and surfaces surrounding engine exhaust system components free of signs of heat damage?		
2.15.3R	Are all fuel system components in fixed inboard engine spaces permanently installed?		
<b>2.16</b>	<b>Steam engines</b>		
2.16.1R	Is the steam engine pressure system supported by an inspection certificate issued by a competent person?		
<b>2.17</b>	<b>LPG engines</b>		
2.17.1R	Are fuel supply arrangements to LPG-fuelled propulsion engines compliant with BS EN 15609, or an equivalent standard, and are any dual-fuel petrol/LPG arrangements of an acceptable type?		
<b>Part 3</b>	<b>Electrical systems</b>	E1	E2
<b>3.1</b>	<b>Battery storage</b>		
3.1.1R	Are all unsealed or open-vented batteries ventilated to prevent risk of explosion through hydrogen accumulation? 		
3.1.2R	Are batteries secure against excessive movement in any direction?		
3.1.3R	Are battery terminals correctly insulated or protected?		
3.1.4R	Are batteries installed away from metallic petrol and LPG system components?		
<b>3.2</b>	<b>Cable specifications and condition</b>		
3.2.1R	Are all electrical cables insulated?		
3.2.2R	Are battery cables of a sufficient current-carrying capacity? 		
3.2.3R	Are all electrical cables free of damage or deterioration? 		
<b>Notes</b>			



<b>3.3</b>	<b>Cable location</b>		
3.3.1R	Are all electrical cables supported in a safe location?		
3.3.2R	Are all electrical cables clear of LPG and fuel pipes?		
3.3.3R	Are spark plug leads free of damage or deterioration and properly supported?		
<b>3.4</b>	<b>Cable connections</b>		
3.4.1R	Are all battery cable connections effective and in good condition?		
3.4.2R	Are all electrical circuit cable connections effective and in good condition?		
3.4.3R	Are all electrical cable connections above bilge water level or suitably protected?		
<b>3.5</b>	<b>Fuses and circuit breakers</b>		
3.5.1R	Are all AC and DC fuses and circuit-breakers complete and in good condition?		
3.5.2R	Are all fuse panels, boxes, holders and consumer units in good condition and complete?		
3.5.3R	Are DC charge circuits that are connected directly to the battery(s) protected by a fuse or circuit-breaker?		
<b>3.6</b>	<b>Battery isolators</b>		
3.6.1R	Are suitable battery isolator(s) fitted and are they as close as practicable to the battery?		
3.6.2R	Do all DC electrical load circuits pass through a battery isolator, or are those requiring a continuous supply, otherwise protected?		
3.6.3R	Are battery isolators, or the means to operate them, in readily accessible positions?		
3.6.4R	Are battery isolators securely mounted and in good condition?		
3.6.5R	Is the location of all battery isolators, or the means to operate them, in open view, or their location clearly marked?		
<b>3.7</b>	<b>Two-wire DC systems</b>		
3.7.1A	Is the DC electrical system made up of 'two-wire' circuits?		
3.7.2R	Is a low resistance return cable provided from the engine or starter motor to the battery?		
<b>3.8</b>	<b>Shore-power and other alternating current (AC) electrical inlet and lead connections</b>		
3.8.1A	Are all AC shore-power lead inlet connections of the correct type in good condition, and suitably protected from the weather?		
3.8.2A	Are all shore-power and other AC power source lead connections of a suitable type?		
3.8.3A	Are all shore-power and other AC power source leads and connectors in good condition?		
<b>3.9</b>	<b>Alternating current systems – multiple power sources and consumer units</b>		
3.9.1A	Is it impossible to connect simultaneously more than one power source to the AC distribution system?		
3.9.2A	Do all AC electrical circuits pass through a consumer unit?		
<b>Notes</b>			



















Part 4 Electrical propulsion systems		E1	E2
<b>4.1</b>	<b>4.1 Electrically propelled boats</b>		
4.1.1	Check Item 4.1.1 is intentionally not used.	X	X
<b>4.2</b>	<b>Electrical propulsion motor and controller</b>		
4.2.1R	Are all parts of the electric-propulsion motor mounting systems secure and in good condition?		
4.2.2R	Is the motor and controller equipment adequately ventilated and in good condition? (G?)		
<b>4.3</b>	<b>Battery charging equipment</b>		
4.3.1R	Is the battery charging equipment ventilated, complete and in good condition? (G?)		
Part 5 Outboard and portable combustion engines, portable fuel systems and spare fuel		E1	E2
<b>5.1</b>	<b>Permanently installed fuel systems supplying outboard and portable engines</b>		
5.1.1R	Do permanently installed fuel systems supplying outboard and portable combustion engines comply with the applicable BSS Requirements for the fuel supply system?		
<b>5.2</b>	<b>Portable fuel systems</b>		
5.2.1R	Are all components of portable fuel systems of suitable proprietary manufacture?		
5.2.2R	Are all components of portable fuel systems complete and in good condition?		
<b>5.3</b>	<b>Spare fuel containers and spare portable petrol tanks</b>		
5.3.1R	Are all spare fuel containers in good condition?		
5.3.2R	Are all spare petrol containers suitable for the purpose? (G?)		
5.3.3R	Are all spare petrol containers, and any spare portable petrol tank, limited to the permitted number, and capacities? (G?)		
5.3.4R	Are all spare petrol containers and any spare portable petrol tank, stored to ensure that any leaking fuel or escaping vapour will not enter the interior of the vessel?		
<b>5.4</b>	<b>Outboard and portable combustion engines</b>		
5.4.1R	Are all outboard and portable combustion engines free of fuel leaks?		
5.4.2R	Are all outboard and portable combustion engines with integral petrol tanks or LPG cartridges stored to ensure that leaking fuel or escaping vapour will not enter the interior of the vessel?		
5.4.3R	Are outboard engine mounting systems in good condition?		
<b>5.5</b>	<b>LPG-fuelled outboard propulsion engines</b>		
5.5.1R	Do the fuel supply arrangements to LPG-fuelled outboard engines comply with BS EN 15609 or an equivalent standard and are any dual-fuel petrol/LPG arrangements of an acceptable type?		
Part 6 Fire Extinguishing, Escape and Carbon Monoxide Alarms		E1	E2
<b>6.1</b>	<b>Portable fire extinguishers</b>		
6.1.1R	Are the correct number of suitable portable fire extinguishers provided, and do they have the correct combined fire ratings?		
6.1.2R	Are portable fire extinguishers distributed around the vessel in readily accessible and safe locations adjacent to escape routes? (G?)		
6.1.3R	Are all portable fire extinguishers in open view or their location clearly marked? (G?)		
<b>Notes</b>			

<b>6.2</b>	<b>Fire blankets</b>		
6.2.1R	If the vessel has permanently installed cooking facilities, is a fire blanket of the correct specification provided?		
6.2.2R	Is the fire blanket located close to the main cooking appliance in a safe and ready-to-use location?	G?	
<b>6.3</b>	<b>Emergency escape</b>		
6.3.1A	Is the vessel provided with adequate means of escape?	G?	
<b>6.4</b>	<b>Carbon monoxide alarms</b>		
6.4.1R	If the vessel has one or more accommodation space(s), are the correct number of carbon monoxide alarms provided?	G?	
6.4.2A	If any solid fuel stoves are installed, and if the vessel has berths within any accommodation space, is a carbon monoxide alarm provided within the same accommodation space(s) as the stove(s)?		
6.4.3R	Are carbon monoxide alarms in open view and of a suitable type?	G?	
6.4.4R	Are carbon monoxide alarms in good condition?		
CO	We advise taking notes on the details of the carbon monoxide alarm(s) where visible		
Alarm 1	Make/Model:	Position:	
Alarm 2	Make/Model:	Position:	
<b>Part 7</b>	<b>Liquefied Petroleum Gas (LPG) systems</b>	E1	E2
<b>7.1</b>	<b>LPG cylinder storage</b>		
7.1.1R	Are all cylinders and cartridges stored in a position where any escaping LPG vapour will be directed safely overboard?		
7.1.2R	Are all self-contained portable LPG appliances stored so that any escaping LPG vapour will be directed safely overboard?	G?	
<b>7.2</b>	<b>LPG cylinder locker and housing LPG-tightness</b>		
7.2.1R	Is the cylinder locker, up to the level of the top of the cylinder valves, or other high-pressure components, free of any path for escaping LPG vapour to enter the interior of the vessel?	G?	
7.2.2R	Are the sealing arrangements on LPG pipework exiting the cylinder locker of the correct type to ensure LPG-tightness to the interior of the vessel, and in good condition?		
7.2.3R	Are side-opening cylinder locker doors located where any escaping LPG vapour would flow overboard unimpeded?		
7.2.4R	Where required, are side-opening locker door seals continuous, in good condition and effective?		
7.2.5R	Is the cylinder housing opening(s) in an 'open location', and is the housing ventilated to the outside?		
7.2.6R	Is the cylinder housing free of any path for escaping LPG vapour to enter the interior of the vessel?		
7.2.7R	Are the sealing arrangements on LPG pipework exiting the cylinder housing of the correct type to ensure LPG-tightness to the interior of the vessel?		
<b>Notes</b>			

<b>7.3</b>	<b>LPG cylinder locker drains</b>		
7.3.1R	Is there a drain in the cylinder locker and is the drain outlet above the waterline?	G?	
7.3.2R	Is the drain opening at or close to the bottom of the cylinder locker?	G?	
7.3.3R	Is the cylinder locker clear of any items that could block the drain?		
7.3.4R	Does the drain line fall continuously from the cylinder locker to the drain outlet and are both ends clear of blockage?		
7.3.5R	Is the drain line material, including the connections, in good condition?		
7.3.6R	Does the drain facility have a minimum appropriate internal diameter or equivalent area?		
<b>7.4</b>	<b>Protecting LPG cylinders and components against damage</b>		
7.4.1R	Are all cylinders secured and stored upright with the valve at the top?		
7.4.2R	Is the cylinder locker or housing secured against unintended movement?		
7.4.3R	Are cylinders in a locker protected against falling objects?		
7.4.4R	Is the cylinder locker or housing clear of any items that could damage the LPG equipment, or ignite escaping LPG vapour?	G?	
7.4.5R	Is the cylinder locker or housing of suitable proprietary manufacture, and has it been maintained to ensure its integrity is retained?		
<b>7.5</b>	<b>Cylinder locker openings</b>		
7.5.1R	Is the cylinder locker opening outside of any engine or battery, space?		
<b>7.6</b>	<b>LPG system shut-off valves</b>		
7.6.1R	Is the LPG system main shut-off valve, or its means of operation, in a readily accessible position?		
7.6.2R	Is the LPG system main shut-off valve, or its means of operation, in open view, or is the location of the valve, or its means of operation, clearly marked?		
<b>7.7</b>	<b>LPG high-pressure system components</b>		
7.7.1R	Are all high-pressure LPG system components accessible for inspection and, either inside a cylinder locker, or in an open location?		
7.7.2R	Where two or more cylinders are connected on the high-pressure side, does each connection have a non-return valve fitted?		
7.7.3R	Are all hoses on the high-pressure side of pre-assembled lengths not exceeding 1m and to the correct specification?		
7.7.4R	Are all high-pressure LPG system components secure and in good condition?		
7.7.5R	Are non-cylinder mounted regulators located to prevent damage?		
7.7.6R	Is the installation free of manually-adjustable regulators?		
<b>Notes</b>			

<b>7.8</b>	<b>LPG pipework, joints and connections</b>		
7.8.1R	Are all LPG pipes made of a suitable material, adequately secured and free from damage?		
7.8.2R	Is the LPG pipe protected where it passes through metal bulkheads or decks?		
7.8.3R	Are all LPG pipe joints accessible for inspection and of the correct type?		
7.8.4R	Are all LPG pipe joints secure, in good condition and competently made?		
7.8.5R	Are all pipework spurs that are no longer connected to an appliance properly capped or plugged?		
7.8.6R	Are all LPG pipes running through petrol engine spaces jointless and adequately supported?		
7.8.7R	Is the LPG pipe at least 75mm from exhaust system and flue components?		
<b>7.9</b>	<b>Low-pressure LPG hoses and hose connections</b>		
7.9.1R	Are all low-pressure LPG hoses accessible for inspection, of the correct material and in good condition?		
7.9.2R	Is all low-pressure LPG hose protected against damage where it passes through bulkheads, decks, or partitions?		
7.9.3R	Is all low-pressure LPG hose at least 75mm from exhaust system and flue components?		
7.9.4R	Are all low-pressure LPG hoses used to connect regulators or appliances, to LPG supply pipework only, and are they a maximum of 1m in length?		
7.9.5R	Are all low-pressure LPG hose connections accessible for inspection, of the correct type, secure and in good condition?		
7.9.6R	Do 'all-hose' systems comply with ISO 10239?		
<b>7.10</b>	<b>Portable appliance connections</b>		
7.10.1R	Are all portable appliance connection points provided with an isolation valve?		
7.10.2R	Are portable appliance hoses connected with bayonet, plug or screwed fittings, complete and in good condition?		
7.10.3R	Are all unused screwed portable appliance connection points properly capped or plugged?		
<b>7.11</b>	<b>Appliance isolation valves</b>		
7.11.1R	Can all appliance supply hoses be isolated through individual appliance isolation valves?		
7.11.2R	Are appliance isolation valves of suitable proprietary manufacture?		
7.11.3R	Are appliance isolation valves, or the means of operating them, readily accessible?		
<b>7.12</b>	<b>Testing for LPG system tightness</b>		
7.12.1R	Is there an LPG test point in the system, or a bubble leak detector in the cylinder locker or housing?		
7.12.2R	Is the LPG system free of leaks as defined in the tightness test?		
<b>Notes</b>	LPG T-Test (circle gas type): Butane/Propane Stable L/U value _____   Time to L/U < 60secs Y/N _____		

Part 8	Appliances and flues	E1	E2
<b>8.1</b>	<b>Appliance fuel and power supply</b>		
8.1.1	Check Item 8.1.1 is intentionally not used	-	-
8.1.2R	Are all liquid-fuelled appliances fitted with shut-off valves, and are the valves or their means of operation, in a readily accessible and safe position?		
<b>8.2</b>	<b>LPG refrigerators on vessels with petrol propulsion engines</b>		
8.2.1R	Where the vessel has a petrol propulsion engine, is any LPG refrigerator of a proprietary room-sealed type, or a Wilderness Boats conversion of an Electrolux RM 212? 		
8.2.2R	On petrol-engined vessels with a Wilderness Boats conversion of an Electrolux RM 212 refrigerator on board, are the burner enclosure and the flame arrestor at the 'lazy tee' in place, and is there suitable documentary evidence of recent servicing? 		
<b>8.3</b>	<b>Installation of appliances in petrol engine spaces</b>		
8.3.1R	Are petrol-engine spaces free of LPG and/or liquid-fuelled appliances?		
<b>8.4</b>	<b>Protection against fire risks from appliance installations</b>		
8.4.1R	Are appliances and surrounding surfaces clear of signs of heat damage and leaking fuel?		
8.4.2R	Are all curtains, blinds and other textile materials near to appliances free of heat damage?		
8.4.3R	Are non-portable appliances secured against unintended movement?		
<b>8.5</b>	<b>Protection against fire risks from appliance flues and exhausts</b>		
8.5.1R	Are all vessel structures, equipment, and curtains, blinds and other textile materials near all appliance flues and exhausts free of signs of heat damage?		
<b>8.6</b>	<b>LPG catalytic heaters</b>		
8.6.1R	Are all LPG catalytic heaters compliant with a suitable manufacturing standard?		
<b>8.7</b>	<b>Flame supervision devices</b>		
8.7.1R	Are flame supervision devices fitted to all LPG and liquid-fuelled appliances that require them?		
<b>8.8</b>	<b>LPG appliance burner operation</b>		
8.8.1R	Are all LPG appliance burners delivering a proper flame? 		
<b>8.9</b>	<b>Ventilation</b>		
8.9.1A	Is the vessel provided with adequate fixed ventilation?   		
<b>8.10</b>	<b>Appliance flues and exhausts</b>		
8.10.1A	Are all appliances requiring a flue or exhaust fitted with one?  		
8.10.2A	Are all appliance flues and exhausts complete and in good condition?   		
8.10.3A	Do all appliance flues and exhausts terminate directly to outside air?  		
8.10.4A	Are all open flues to LPG appliances operating effectively?  		
8.10.5A	Are all solid fuel appliances free of unintended gaps?  		
<b>Notes</b>			

Part 9	Pollution prevention	E1	E2
9.1	<b>Engine/gearbox oil leak collection</b>		
9.1.1R	Will all oil leaks from the engine/s or gearbox/es be collected in an engine tray or oil-tight area?		
9.1.2R	Where a fixed bilge pump or fixed bilge suction line draws from an engine tray or oil-tight area is the risk of pollution minimised?	G?	W?
9.2	<b>Sanitation systems</b>		
9.2.1R	Is a closable valve fitted in the discharge line of any toilet or toilet holding tank, with overboard discharge?	W?	
<b>Notes</b>			

**Section 3 – Appliances, ventilation and portable fire extinguishers** Records must be accurate at the time of Certification and must be retained in Examiner’s files/on BSS Database for not less than 6 years

Boat name:

Certification Date:

**1. Check 8.9.1 - Main accommodation space(s) area:**

**1a. Installed appliances, and the minimum fixed ventilation Requirement**

**Note** – A record of all appliances must be made whether they require fixed ventilation or not.

**Suggested key for Flue column:** U = Un-flued, F = Flued, B = Balanced flued, H= Solid Fuel Stove

**Suggested key for Fuel column:** D = Diesel, G = LPG, S = solid fuel, E = Electric

Appliance type	Nos	Make & model	Flue	Fuel	kW	Ventilation required (mm <sup>2</sup> )
Freestanding cooker			U			
Built-in cooker			U			
Separate hob			U			
Separate oven/grill			U			
Central heating boiler						
Instant. water heater						
Solid fuel stove			H			
Refrigerator						
Number of Persons (P)						

Fixed ventilation Requirement (in mm<sup>2</sup>) = [2200 x U] + [650 x P] + [550 x H] + [440 x F]

Total minimum fixed ventilation Requirement (mm<sup>2</sup>) (50% of the total)

**1b. Total effective area of fixed ventilation.**

Location of H/L vent	Vent type/specification	Area per vent (mm <sup>2</sup> )	N <sup>o</sup> . of vents	High Level Sub-Total area (mm <sup>2</sup> )

Total effective area of fixed ventilation at high level (mm<sup>2</sup>)

High level minimum Requirement (mm<sup>2</sup>) (50% of the total)

High level fixed ventilation compliant? Yes:  No:

Location of L/L vent	Vent type/specification	Area per vent (mm <sup>2</sup> )	N <sup>o</sup> . of vents	Low Level Sub-Total area (mm <sup>2</sup> )

Total effective area of fixed ventilation at low level (mm<sup>2</sup>)

Low level minimum Requirement (mm<sup>2</sup>) (50% of the total)

Low level fixed ventilation compliant? Yes:  No:

Main area compliant at Check 8.9.1 compliant? Yes:  No:

Was the 10% divergence allowance between high and low level used to achieve compliance at Check 8.9.1 Yes:  No:

**2. Check 8.9.1 - Secondary/separated accommodation space(s) area:**

Note – this section (#2) of the Record should only be completed where there are accommodation space(s) containing fuel burning appliances that are separated from the main accommodation space(s) that contain fuel burning appliances

**2a. Installed appliances, and the minimum fixed ventilation Requirement**

Appliance type	Nos	Make & model	Flue	Fuel	kW	Ventilation required (mm <sup>2</sup> )
Number of Persons (P)						

Fixed ventilation Requirement (in mm<sup>2</sup>) = [2200 x U] + [650 x P] + [550 x H] + [440 x F] \_\_\_\_\_

Total minimum fixed ventilation Requirement (mm<sup>2</sup>) \_\_\_\_\_

**2b. Total effective area of fixed ventilation.**

Location of H/L vent	Vent type/specification	Area per vent (mm <sup>2</sup> )	N <sup>o</sup> . of vents	High Level Sub-Total area (mm <sup>2</sup> )

Total effective area of fixed ventilation at high level (mm<sup>2</sup>) \_\_\_\_\_

High level minimum Requirement (mm<sup>2</sup>) (50% of the total) \_\_\_\_\_

High level fixed ventilation compliant? Yes:  No:

Location of L/L vent	Vent type/specification	Area per vent (mm <sup>2</sup> )	N <sup>o</sup> . of vents	Low Level Sub-Total area (mm <sup>2</sup> )

Total effective area of fixed ventilation at low level (mm<sup>2</sup>) \_\_\_\_\_

Low level minimum Requirement (mm<sup>2</sup>) (50% of the total) \_\_\_\_\_

Low level fixed ventilation compliant? Yes:  No:

Main area compliant at Check 8.9.1 compliant? Yes:  No:

Was the 10% divergence allowance between high and low level used to achieve compliance at Check 8.9.1 Yes:  No:

**3. Portable fire extinguisher details**

Location	Make & model	Fire ratings		Cert. mark
		A	B	
Total ratings				



